

SECTION A-A

SECTION B-B WITH CURB & GUTTER

SECTION B-B

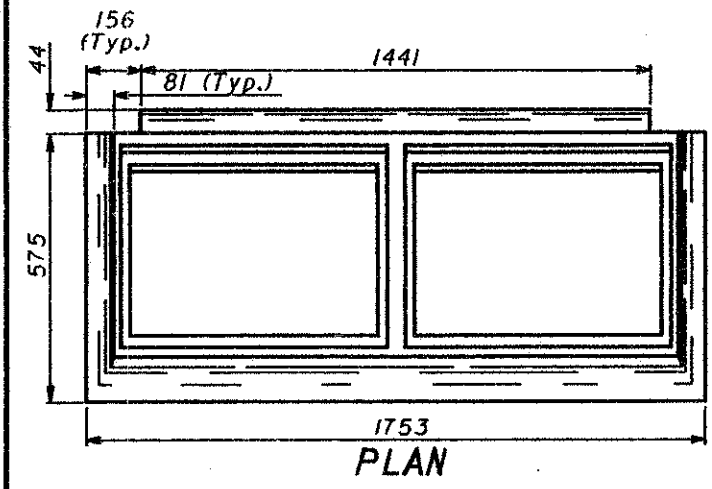

PLAN

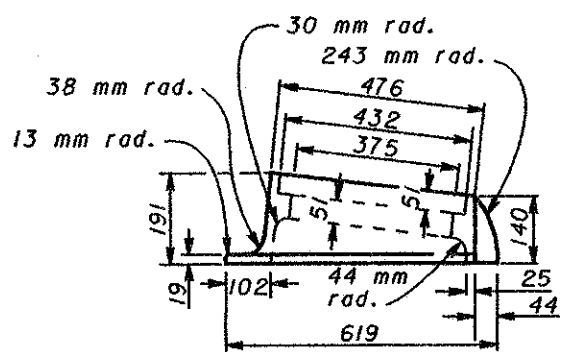

END VIEW FRAME

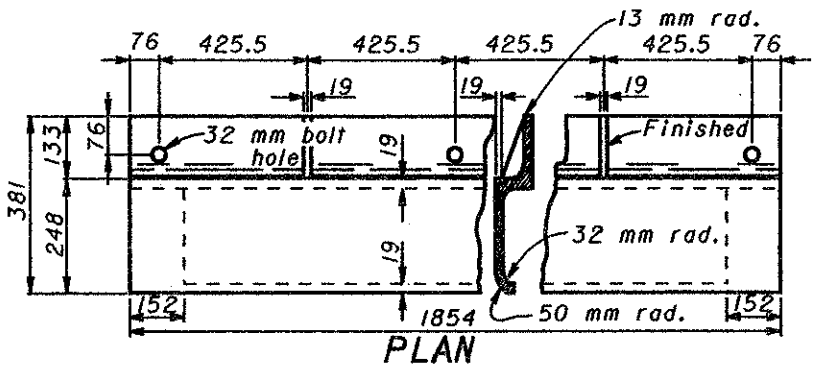

PLAN

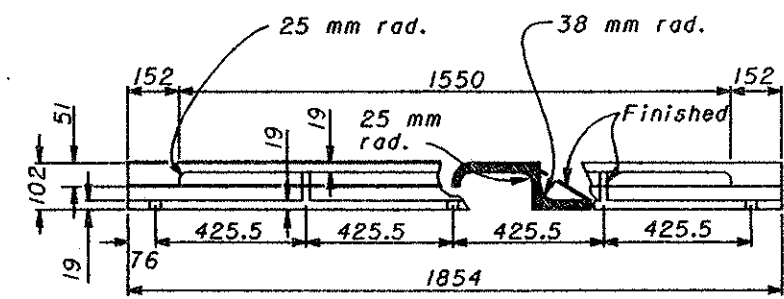

FRONT VIEW

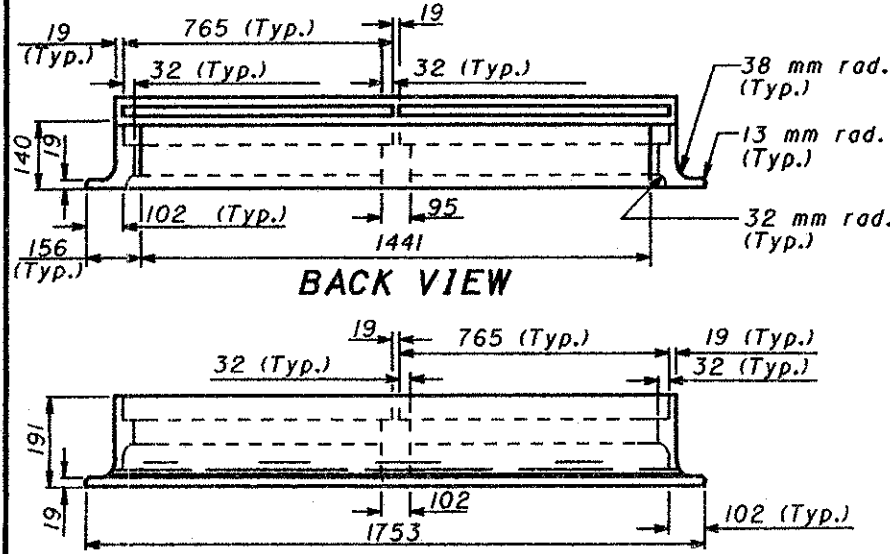

BACK VIEW

FRONT VIEW FRAME

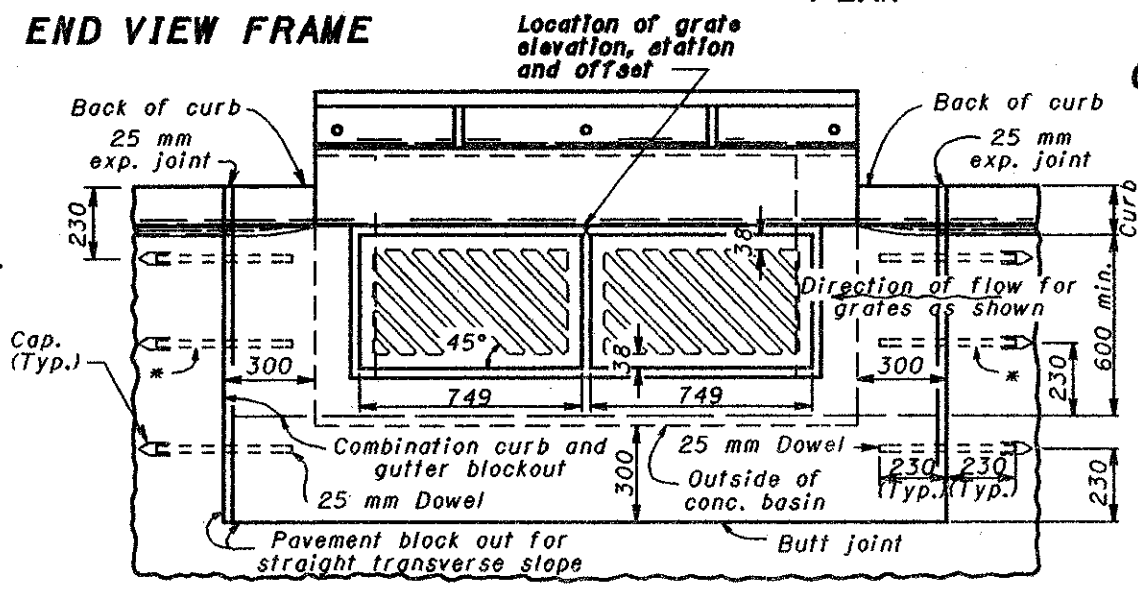

PLAN OF CATCH BASIN AND PAVEMENT JOINTS

\*Dowel location for curb & gutter

**NOTES**

**GRATES:** Two required. For details, see Std. Constr. Dwg. CB-2.2M. Grate "V" shall be provided unless the plans specifically require the diagonal grate. If the diagonal grate is specified, it shall be placed so that the diagonal bars direct drainage flow toward the curb.

**CASTINGS:** The design shall be essentially the same and equally as strong as those shown. Minimum mass: Curb Casting 138 kg, two Grates 115 kg, Frame 267 kg, and two Grates "V" 95 kg.

**BEARING AREAS:** The frame and grate shall be so fitted and finished as to provide a firm and even seat. No projections shall exist on bearing areas and the grate shall seat in its frame without rocking.

**WALLS:** When used in place of concrete, brick side walls shall be 200 mm nominal thickness.

**PRECAST CONSTRUCTION:** Permitted, except for the apron. Concrete shall meet requirements of CMS 706.13 with a minimum of 4% entrained air in the hardened concrete. Precast walls shall have a minimum thickness of 150 mm and reinforcing shall be sufficient to permit shipping and placement without damage.

**MINIMUM DEPTH:** The minimum depth shall be the outside diameter (O.D.) of the outlet pipe plus 360 mm.

**OPENINGS:** Pipe openings shall be the O.D. of the pipe being supplied plus 50 mm when fabricated or field cut. The interstitial space shall be filled with grout per CMS 601.

**DOWELS:** Four 25x460 mm dowels are required for concrete pavement or gutter blockout. See BP-2.2M for dowel details.

**BLOCKOUT:** Blockouts shall be paved with Class C concrete in PCC pavement or gutter and paid for as part of the pavement or gutter with no deduction in pavement, curb or gutter quantities because of castings. A Class C concrete apron the size of the 600 mm gutter blockout shall be cast-in-place in asphalt pavement (no dowels required) with the cost included in the catch basin bid price. No deduction to be made in curb quantities.

All dimensions are in millimeters unless otherwise noted.

This Drawing Replaces CB-3.

BUREAU OF LOCATION AND DESIGN OHIO DEPARTMENT OF TRANSPORTATION		DATE
<b>CATCH BASIN No. 3</b>		7-12-95
STANDARD CONSTRUCTION <b>CB-2.1M</b> DRAWING		
APPROVED <i>W.K. Hulman</i>		ENGR., L & D

