

NOTES

PAYMENT: Walk and curb, Items 608 and 609, shall be measured through the curb ramp area and paid for under their respective Items. Item "608, each, Curb ramp" constructed in new curb and walk shall include the cost of any additional materials, grading, forming and finishing. Item "608, square foot, Curb Ramp", constructed in existing curb and walk shall include the cost of furnishing all materials, grading, forming, and finishing of the curb and walk of the curb ramp. Removal of existing curb and walk shall be paid for under Item 202.

SURFACE TEXTURE shall be obtained by coarse brooming transverse to the ramp slopes and shall be rougher than adjacent walk.

JOINTS shall be provided in the curb ramp as extensions of walk joints and consistent with 608.03 requirements for a new concrete walk. A 1/2 inch 705.03 expansion joint filler shall be provided around the edge of ramps built in existing concrete walk. Lines shown on this drawing indicate the ramp edge and slope changes and are not necessarily joint lines.

DIMENSIONS, LOCATION AND TYPE of curb ramp may be modified as directed by the engineer in accordance with the following:

- **TYPE** of curb ramp built shall be the type that best fits the location unless a type is specified in the plans. Type 1 is preferred because of the flatter side slopes. Any combination of Type 1 and 2 side slopes on opposite sides of a ramp may be used to best fit the site conditions. TYPE 1 Curb Ramps (Flared sides) should be used at locations where pedestrians must walk across the ramp at an angle. Typical Curb Ramps (a), (b), and (e) are examples. TYPE 2 Curb Ramps (Steep sides) should be used where pedestrians would not normally walk across or perpendicular to the centerline of the ramp. Sides of these ramps must be parallel to the pedestrian flow. Typical Curb Ramps (c), (d), (f) and (g) are examples.
- **SLOPE** of the ramp toward the curb is preferred to be 12:1 or flatter related to the horizontal but the maximum slope shall be 12:1 relative to the existing or proposed walk slope. The minimum ramp length is 6 ft. from the back of a 6 in. curb and may be increased where feasible to obtain a flatter ramp slope or to better blend with the walk configuration.
- **WIDTH** of ramp shall normally be 4 ft. but a minimum width of 3 ft. may be used to better fit the walk configuration or where site conditions are restricted by narrow walks, pole foundations, drainage inlets, etc. The width may be tapered.
- **WALK THICKNESS** in the ramp slopes shall be 4 in. minimum or thicker as necessary to match adjacent walk thickness.

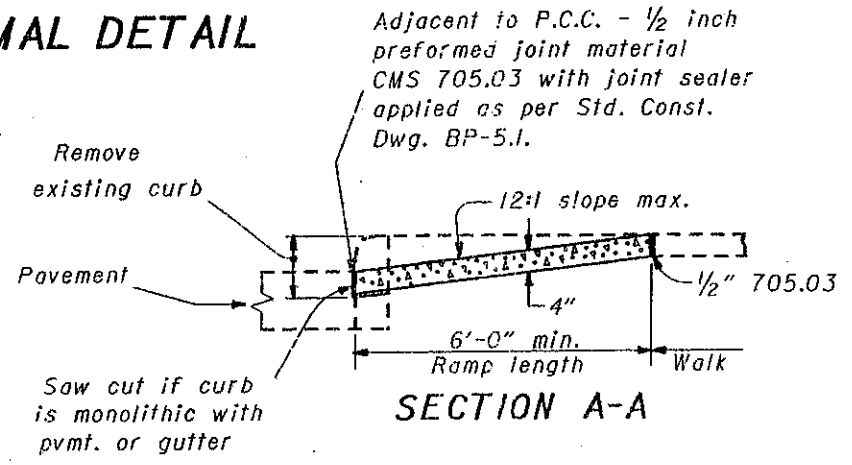
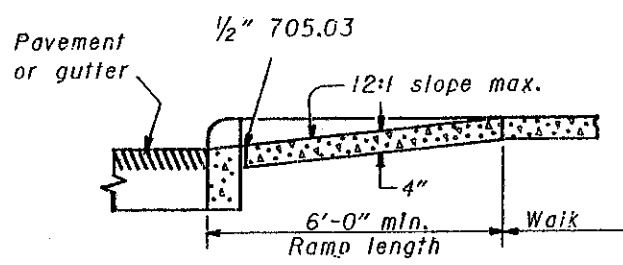
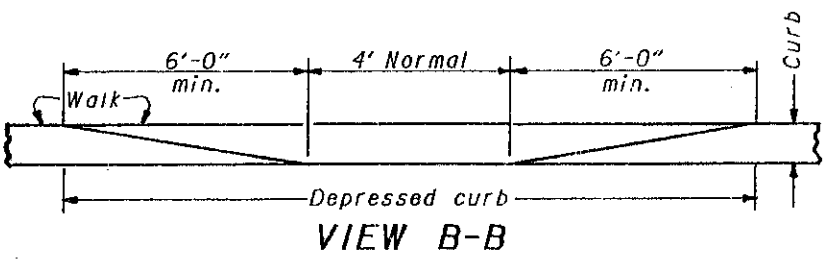
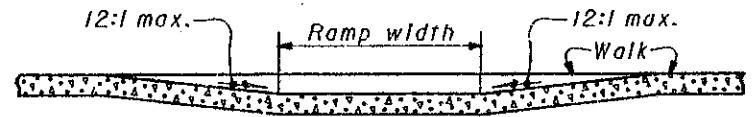
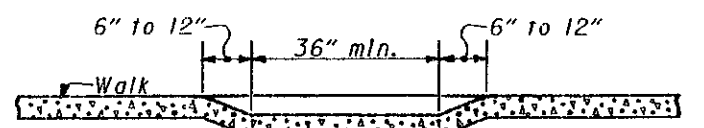

Adjacent to P.C.C. - 1/2 inch preformed joint material CMS 705.03 with joint sealer applied as per Std. Const. Dwg. BP-5.1.

Remove existing curb
Saw cut if curb is monolithic with pvm. or gutter

BUREAU OF LOCATION AND DESIGN OHIO DEPARTMENT OF TRANSPORTATION	
CURB RAMPS	DATE 2-21-92 10-30-92
STANDARD CONSTRUCTION DRAWING	BP-7.1
APPROVED <i>E.K. Huttmann</i> ENGR., L & D	