

CL SURVEY & CONSTRUCTION
S.R. 91

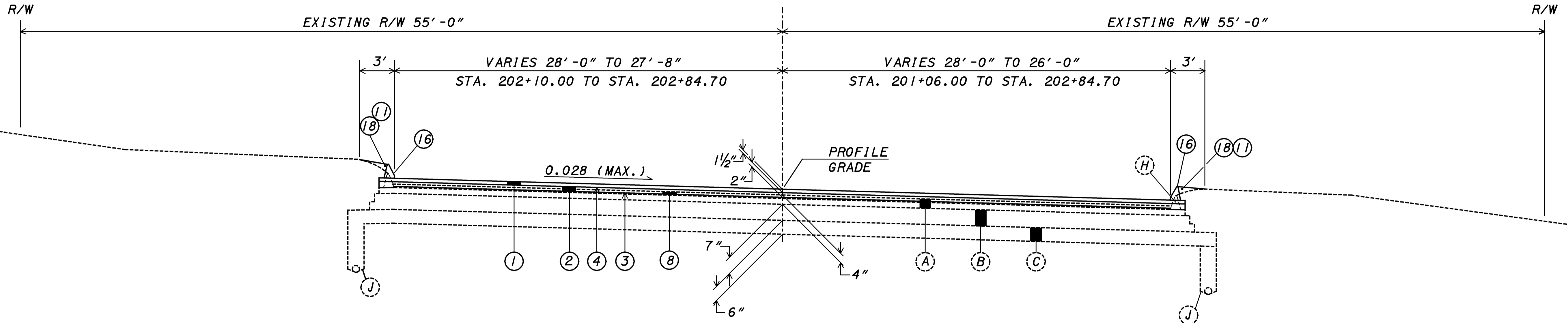

S.O.M. CENTER ROAD - S.R. 91

TRANSITION SECTION

STA. 194+40.84 TO STA. 197+70.84 - 330.00 LIN. FT.

SUPERELEVATED SECTION

STA. 197+70.84 TO STA. 201+06.00 - 335.16 LIN. FT.

TRANSITION SECTION

STA. 201+06.00 TO STA. 202+84.70 - 178.70 LIN. FT.

REFERENCE	
DESCRIPTION	SHEET
LEGEND	3
CURB DETAIL	3

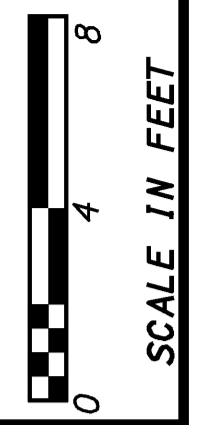

CALCULATED
BJK
CHECKED
DRL

TYPICAL SECTIONS
SR-91
STA. 194+40.84 TO STA. 202+84.70

CUYAHOGA COUNTY
LAKE COUNTY
CUY/LAK-91-15.42/0.00

PLOTTED BY: fkonopka
PLOTTED FROM: \\users\bkruse\p\d\09864\09864.dgn
PLOT SUBMITTED: 09-OCT-1998 08:18