

CITY OF MENTOR PREEMPT CONFIRMATION LIGHT ISOLATION PANEL

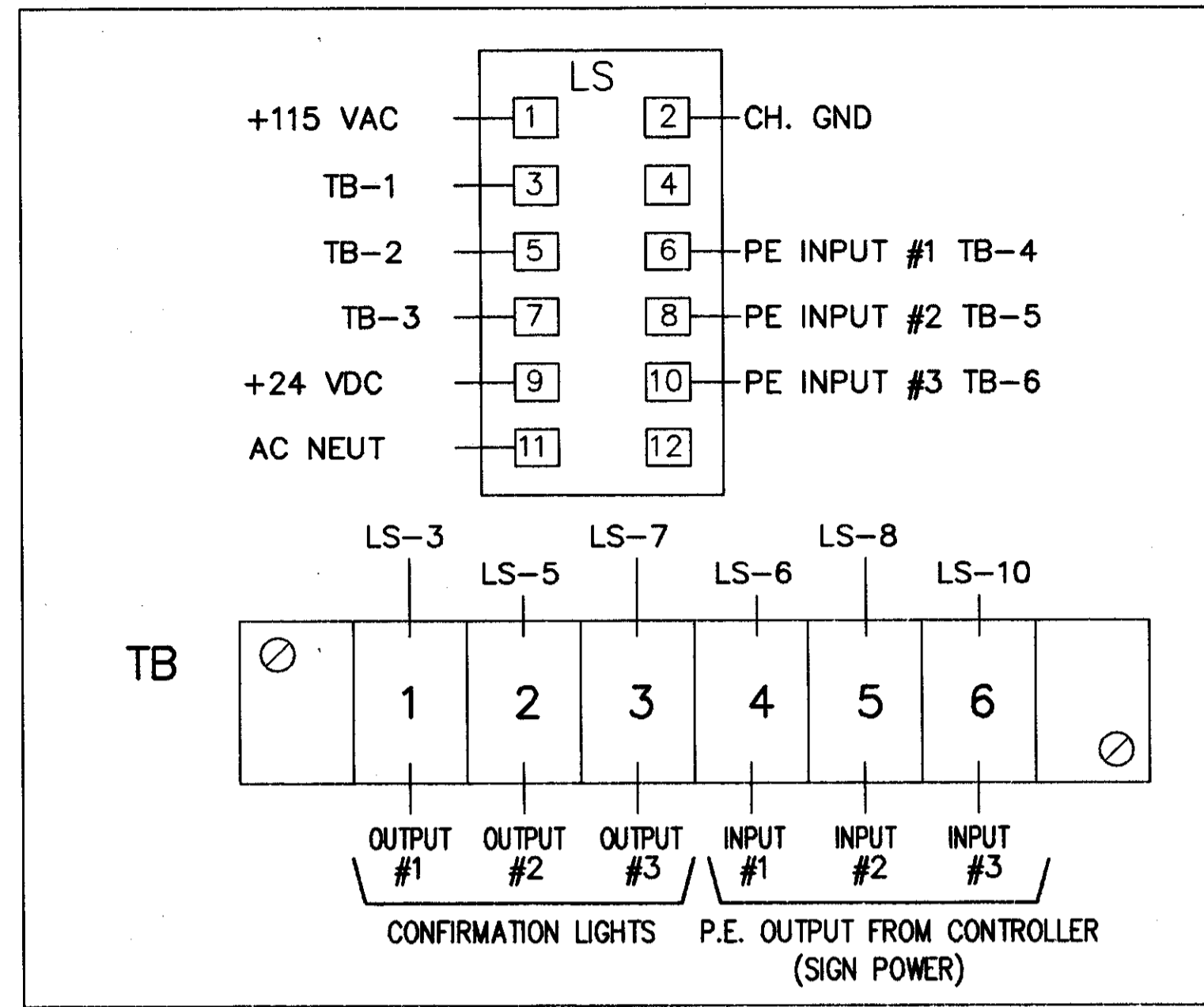

9-PIN HARNESS WIRING

WIRE COLOR	PIN NUMBER	FUNCTION
BLACK	1	115 VAC (AC+)
WHITE	2	AC RETURN (AC-)
GREEN	3	CHASSIS GROUND
	4	NOT USED
GRAY/WHITE	5	Ch A PRIORITY CONTROL OUTPUT
BLUE/WHITE	6	Ch B PRIORITY CONTROL OUTPUT
VIOLET/WHITE	7	Ch C PRIORITY CONTROL OUTPUT
BROWN/WHITE	8	Ch D PRIORITY CONTROL OUTPUT
GRAY/BLACK	9	LOGIC GROUND

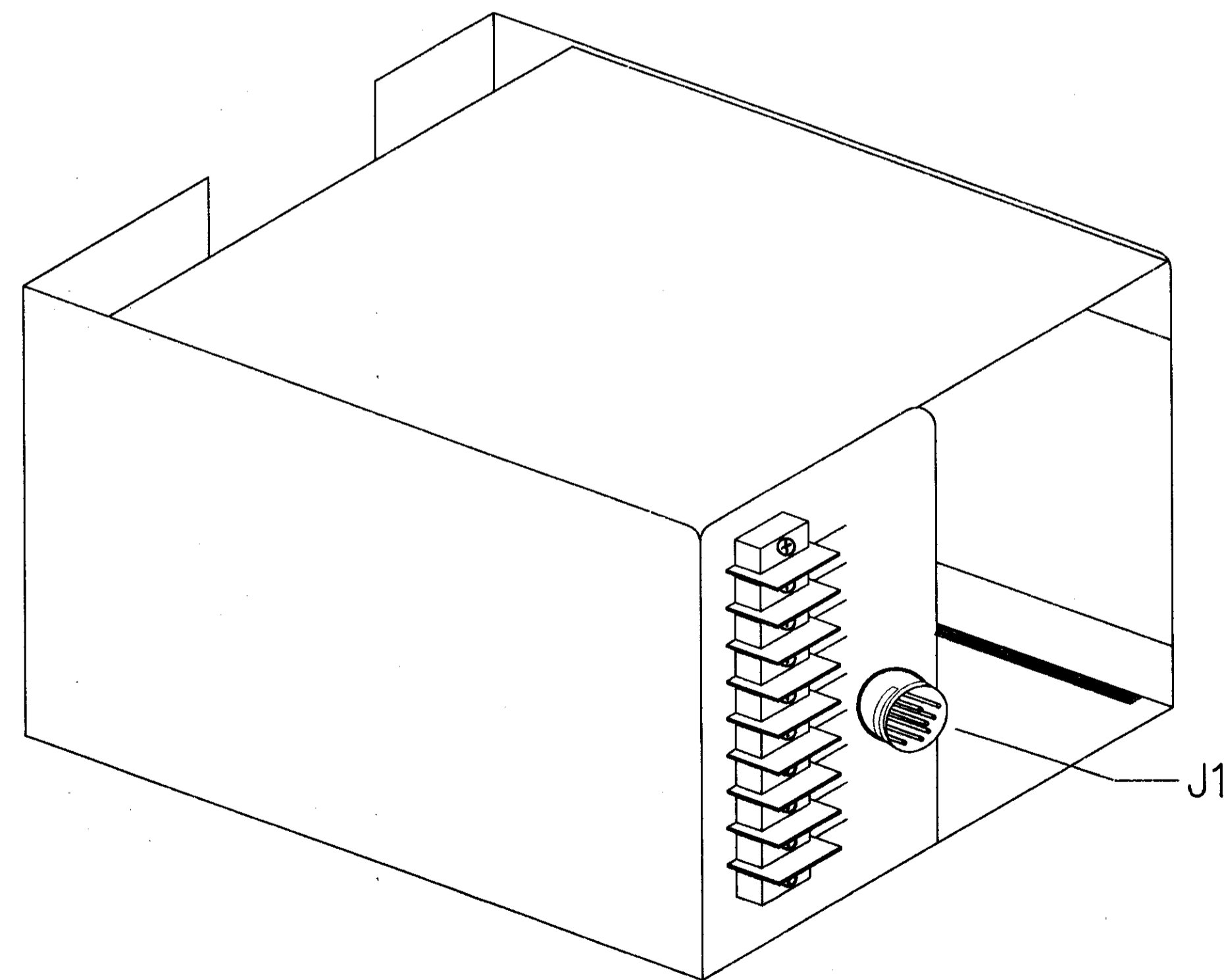

MODEL 760 CARD RACK

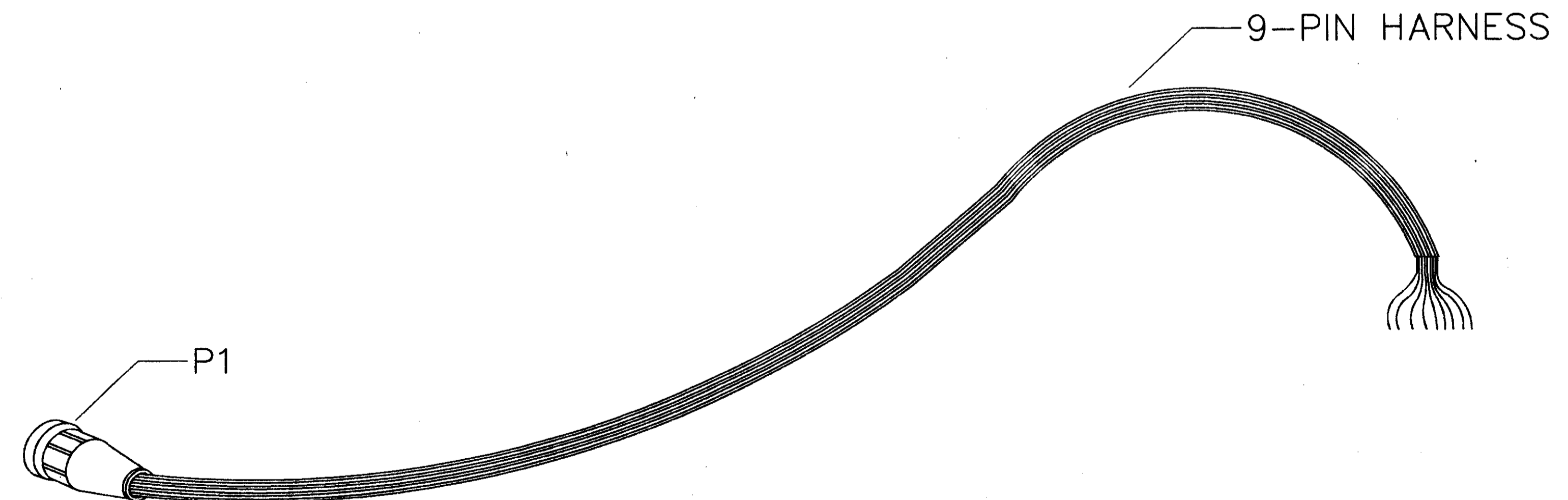

DATE: 06-28-01 - H:\CT\97125\SDSK\97125TNS.DWG - PLOT SCALE = 1 : 1

CALCULATED  
A.E.P.  
CHECKED  
J.M.H.

S.R. 615  
TRAFFIC CONTROL GENERAL NOTES

LAK-IR90/SR615-9.26/1.51