

STRUCTURAL STEEL BOLSTER
See table below for additional dimensions.

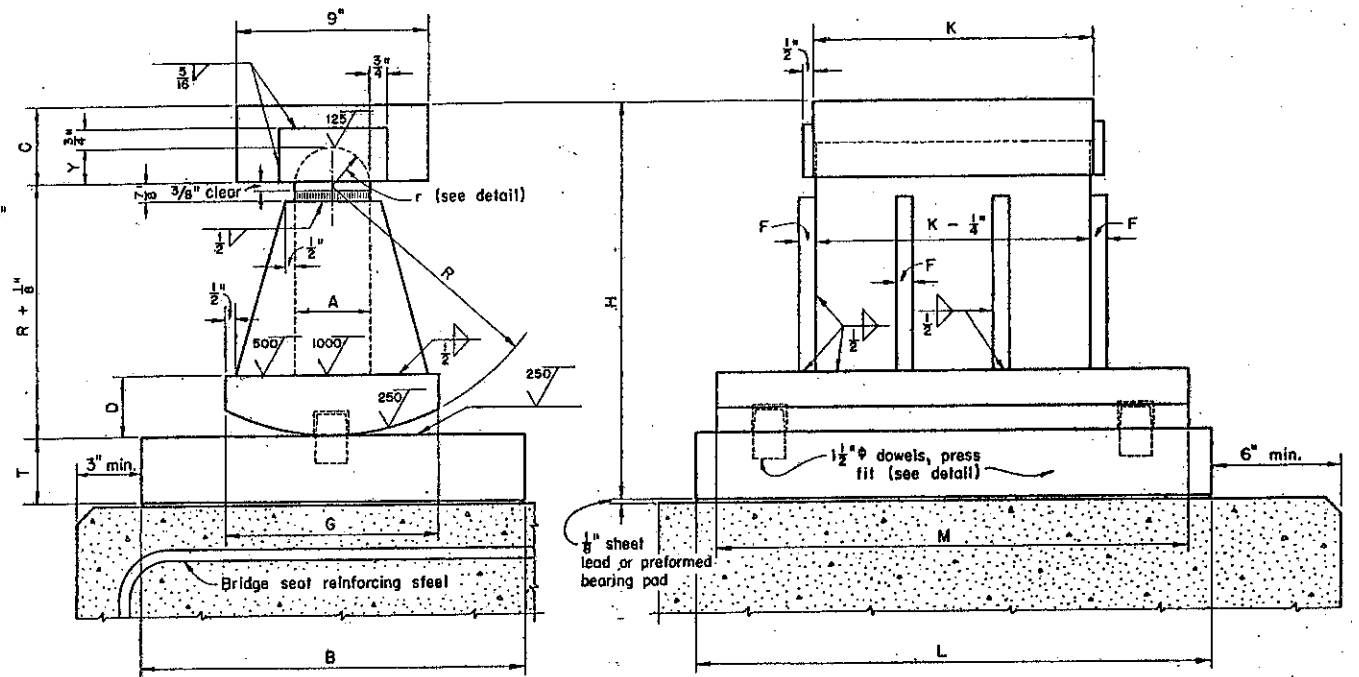

STRUCTURAL STEEL ROCKER
See table below for additional dimensions.

Bolster No.	Rocker No.	Dimensions (inches)													Weight each (lb.)		Maximum Load (lb.)
		A	B	C	D	F	G	H	K	L	M	R	T	Y	Bolster	Rocker	
	R-75	2 1/2	8	2 1/2	1 3/4	1/2	7	9 3/8	9	18	16	5 1/2	1 1/2	1 3/8		205	75,000
B-100	R-100	2 1/2	10	2 1/2	2	1/2	7 1/2	10 5/8	9	19	17	6 1/2	1 1/2	1 3/8	225	250	100,000
B-125	R-125	3	11	3	2	1/2	8	12 1/8	10 1/2	20	18	7 1/2	1 1/2	1 7/8	295	315	125,000
B-150	R-150	3	12	3	2 1/4	1/2	8 1/2	13 3/8	11 1/2	22	19	8 1/2	1 3/4	1 7/8	360	400	150,000
B-175	R-175	3	14	3 1/2	2 1/2	1/2	9	15 5/8	12	23	20	9 1/2	2	1 7/8	455	505	175,000
B-200	R-200	3	16	3 1/2	2 3/4	5/8	9	16 3/8	12	24	21	10 1/2	2 1/4	1 7/8	540	605	200,000
B-225	R-225	3	17	3 1/2	2 3/4	5/8	9	16 3/8	13	25	22	11	2 1/4	1 7/8	590	665	225,000
B-250	R-250	3 1/2	18	3 1/2	2 3/4	3/4	10	17 3/8	13	26	23	11 1/2	2 1/2	1 11/16	695	775	250,000
B-275	R-275	3 1/2	19	3 1/2	3 1/4	3/4	12	18 3/8	14	27	24	12	2 3/4	1 11/16	800	945	275,000
B-300	R-300	3 1/2	20	3 1/2	3 1/4	3/4	12	19 1/8	14	28	25	12 1/2	3	1 11/16	895	1050	300,000

Weights given are for one rocker or bolster complete (including sheet lead, anchor bolts and washers).

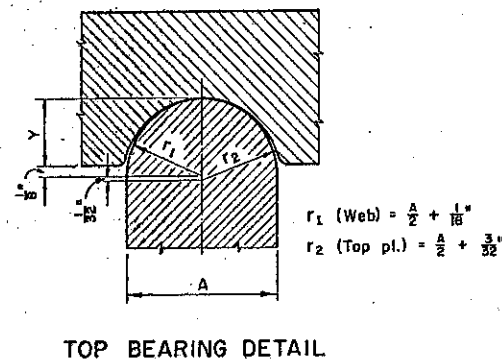

TOP BEARING DETAIL

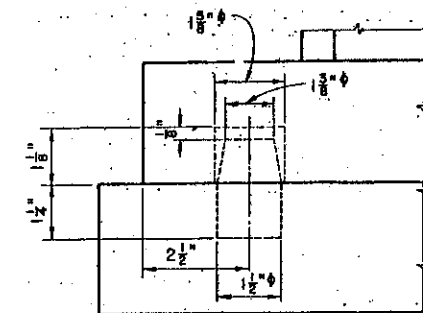

DOWEL DETAIL

DESIGN SPECIFICATIONS: This standard drawing conforms to the requirements of "Design Specifications for Highway Structures" of the State of Ohio, Department of Highways, dated October 1, 1951, together with revisions thereof dated July 15, 1952, April 1, 1954 and February 1, 1955.

LIMITATION: This rocker and bolster design shall not be used where the anticipated movement is in excess of 2 inches.

REVISIONS. 2-2-59		STATE OF OHIO DEPARTMENT OF HIGHWAYS DIVISION OF DESIGN AND CONSTRUCTION BUREAU OF BRIDGES	
STANDARD ROCKERS AND BOLSTERS FOR STEEL BEAM AND GIRDER BRIDGES			
REACTIONS 75,000 lb. TO 300,000 lb.			
APPROVED: DATE: 3-1-55	<i>Richard D. St.</i> ENGINEER OF BRIDGES		DRAWING NUMBER RB-1-55
PREPARED MFR CFB JCM WHR	TRACED JVP	CHECKED GEM OPH	REVIEWED GSO BFG CHA AJF DHO