

CABLE SHALL BE RUN INTO SIGNAL HEAD AND CONNECTIONS ARE TO BE MADE AT TERMINAL BLOCKS.

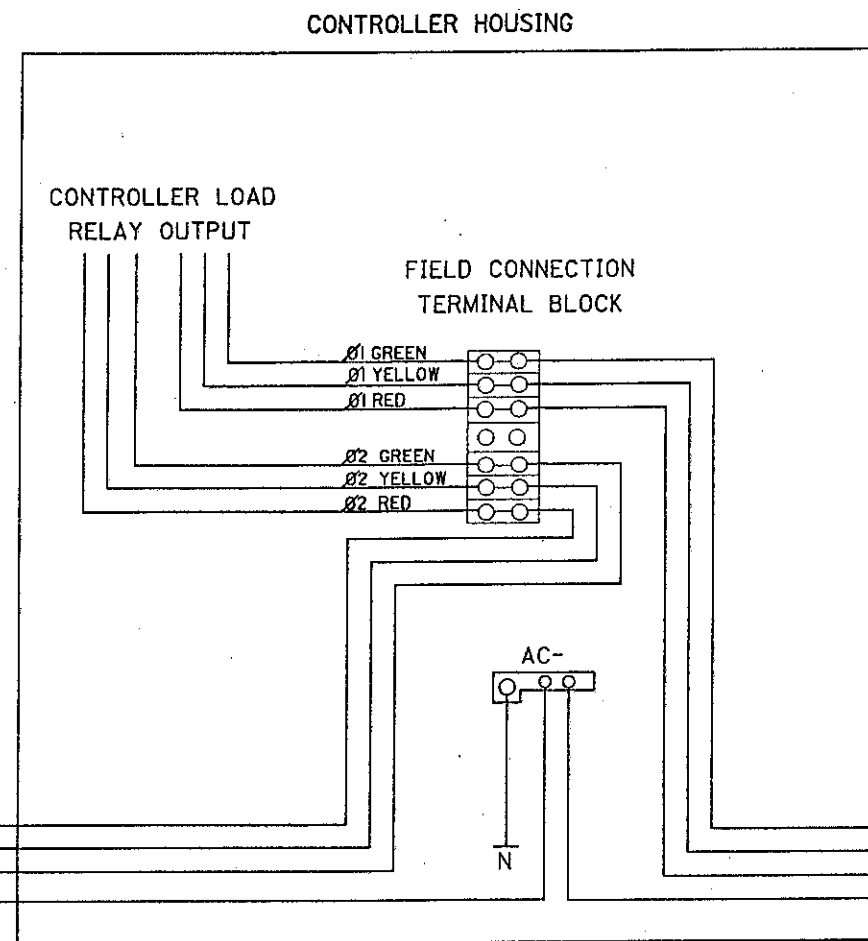

TYPICAL SIGNAL HEAD HOOK-UP

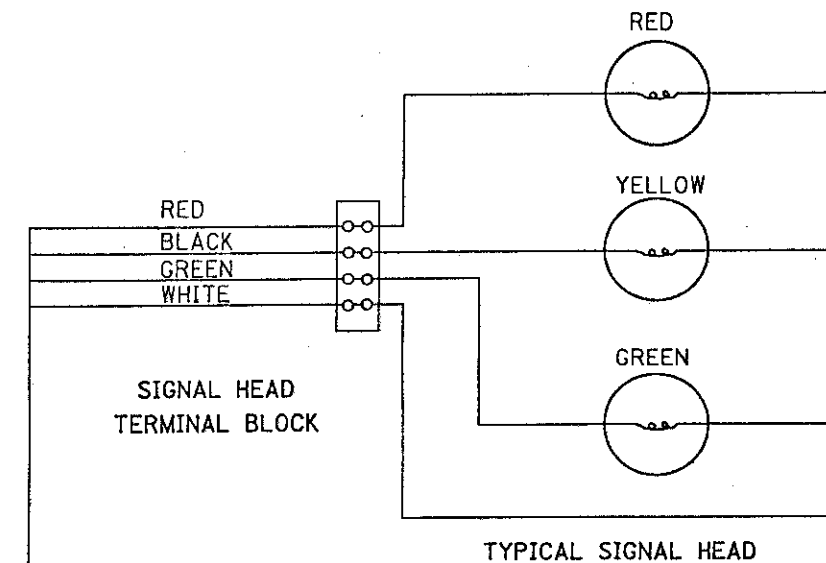
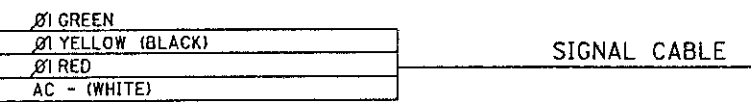
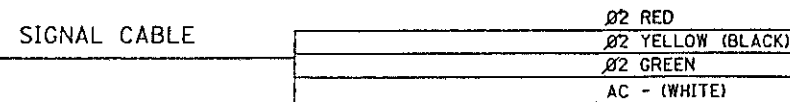

**GENERAL NOTES:**

1. LIGHTNING PROTECTION, AS REQUIRED IN 733.04 SHALL BE PROVIDED FOR SOLID STATE ELECTRONIC CONTROLLERS AND DETECTORS.
2. SIGNAL CABLE SHALL BE 5/C NO. 14 AWG AS SPECIFIED IN 732.19. ALL ELECTRICAL CONNECTIONS TO BE MADE AT TERMINAL BLOCKS USING LOCK FORK TERMINALS. SPLICES IN SIGNAL CABLE SHOULD BE AVOIDED BUT IF NECESSARY SPLICE KITS SHALL BE USED. ALL CONNECTIONS AT SPLICE POINTS SHALL BE SOLDERED.
3. SIGNAL TIMING SETTINGS SHALL BE AS SHOWN IN THE PLANS OR PROVIDED TO THE CONTRACTOR BY THE ENGINEER PRIOR TO IMPLEMENTATION OF SIGNAL CONTROL. THE CONTRACTOR SHALL PERIODICALLY MONITOR THE SIGNAL OPERATION TO DETERMINE FAILURE OR INEFFICIENT OPERATION.

ALL EQUIPMENT FAILURES INCLUDING TIMING MECHANISMS AND DETECTORS SHALL BE REPORTED TO THE ENGINEER AND FULLY REPAIRED BY THE CONTRACTOR AS SOON AS POSSIBLE, BUT IN NO CASE LONGER THAN 8 HOURS FOLLOWING NOTIFICATION OF THE

CONTRACTOR BY THE ENGINEER. ALL FAILURES RESULTING IN UNSAFE OPERATIONS OF THE SIGNAL (i.e., SIGNAL OR LAMP FAILURE, SHORT-TIMING OF YELLOW OR ALL RED INTERVALS, MIS-AIMED SIGNALS, CONFLICTING DISPLAYS) SHALL RESULT IN THE CONTRACTOR 2-WAY RADIOS, TO CONTROL TRAFFIC THROUGH THE WORK AREA UNTILL THE SIGNAL IS FULLY REPAIRED. FAILURES SHALL INCLUDE SITUATIONS CAUSED BY TRAFFIC ACCIDENTS, ACTS OF GOD OR ANY OTHER CAUSE WHETHER UNDER THE CONTROL OF THE CONTRACTOR OR NOT.

IF THE ENGINEER DETERMINES THAT THE SIGNAL OPERATION, ALTHOUGH IN ACCORDANCE WITH THE PLANS AND PREVIOUS ORDERS, IS NOT PROVIDING ACCEPTABLE SAFE AND EFFICIENT MOVEMENT OF TRAFFIC, THE ENGINEER SHALL ORDER THAT APPROPRIATE CHANGES SUCH AS TIMING ALTERATIONS, SIGNAL OR DETECTOR RELOCATIONS, ETC. BE MADE TO REMEDY THE SITUATION, AT NO ADDITIONAL COST TO THE STATE. TIMING CHANGES AND SIGNAL RELOCATIONS SHALL BE IMPLEMENTED WITHIN FOUR HOURS, DETECTOR RELOCATIONS AND CHANGES WITHIN 24 HOURS. FAILURE TO MAKE REQUIRED CHANGES WITHIN THESE TIME LIMITS SHALL RESULT IN THE ASSESSMENT OF LIQUIDATED DAMAGES OF \$100.00 PER CALENDAR DAY UNTILL THE CHANGES ARE COMPLETED.

<h1>M E T R I C</h1>	
BUREAU OF DESIGN SERVICES DIVISION OF HIGHWAYS OHIO DEPARTMENT OF TRANSPORTATION	
MAINTENANCE OF TRAFFIC	DATE 01/30/95
PRE-TIMED-WIRING DIAGRAM FOR SIGNALIZED CLOSING 1 LANE OF A 2 LANE HIGHWAY	
STANDARD CONSTRUCTION DRAWING	<b>MT-96.25M</b>
APPROVED <i>[Signature]</i> ENGR. OF DESIGN SERVICES	