

MICROFILMED
DEC 11 1987

FED. RD. DIVISION	STATE	PROJECT	456
2	OHIO	ACI-1103(21)	488

LAKE COUNTY
LAK-1-12.89

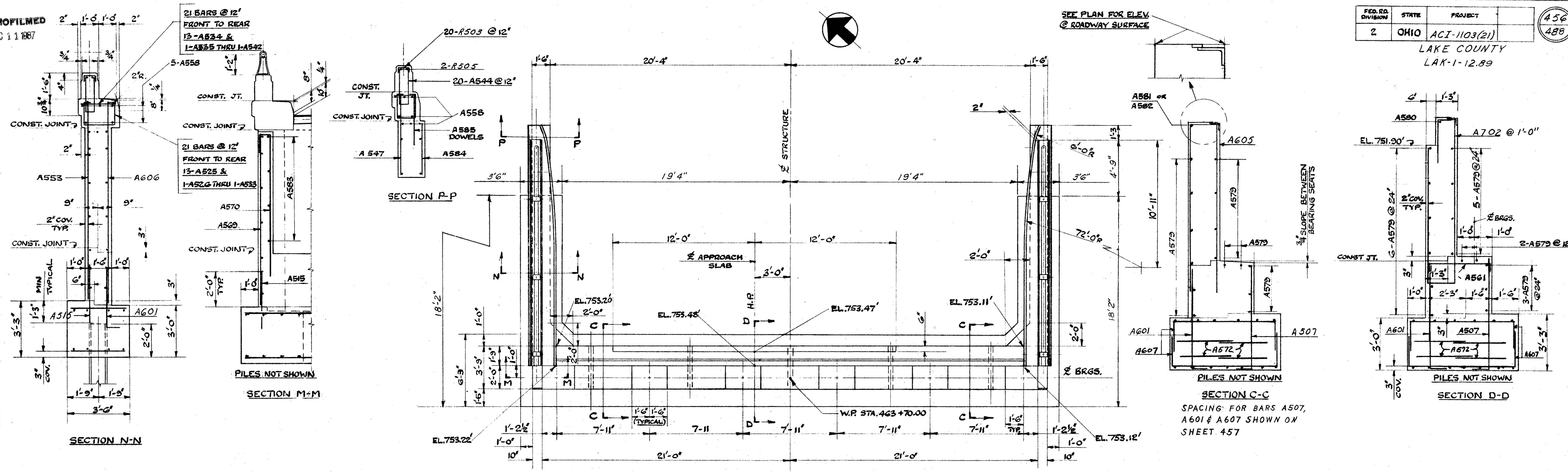

PLAN - EAST ABUTMENT, SOUTH BRIDGE

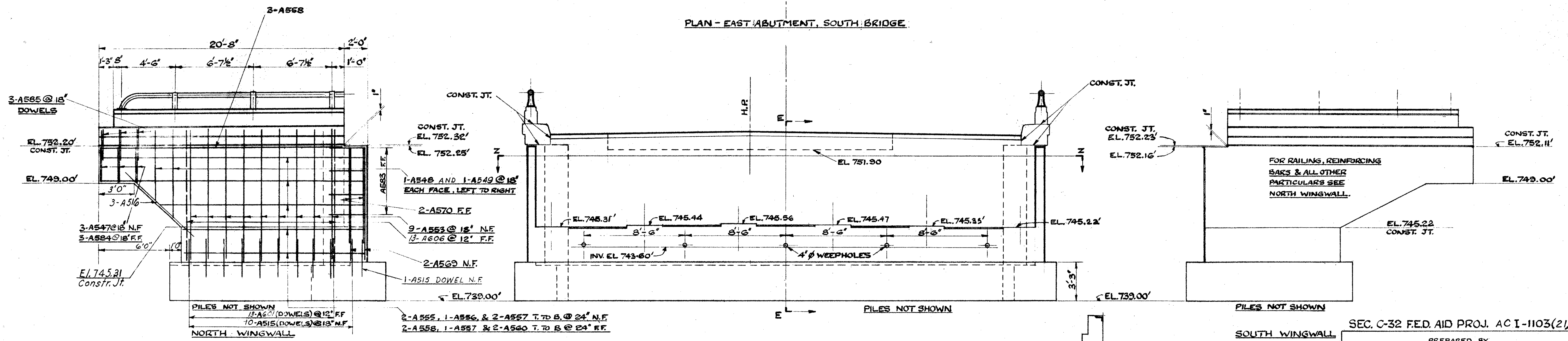

ELEVATION - EAST ABUTMENT, SOUTH BRIDGE

EAST ABUTMENT, SOUTH BRIDGE - AS DRAWN
EAST ABUTMENT, NORTH BRIDGE - OPP. HAND.

NOTE: ABUTMENT FTG. ON PILES
POINT BEARING ON ROCK
DESIGN LOAD 35 TON PER PILE

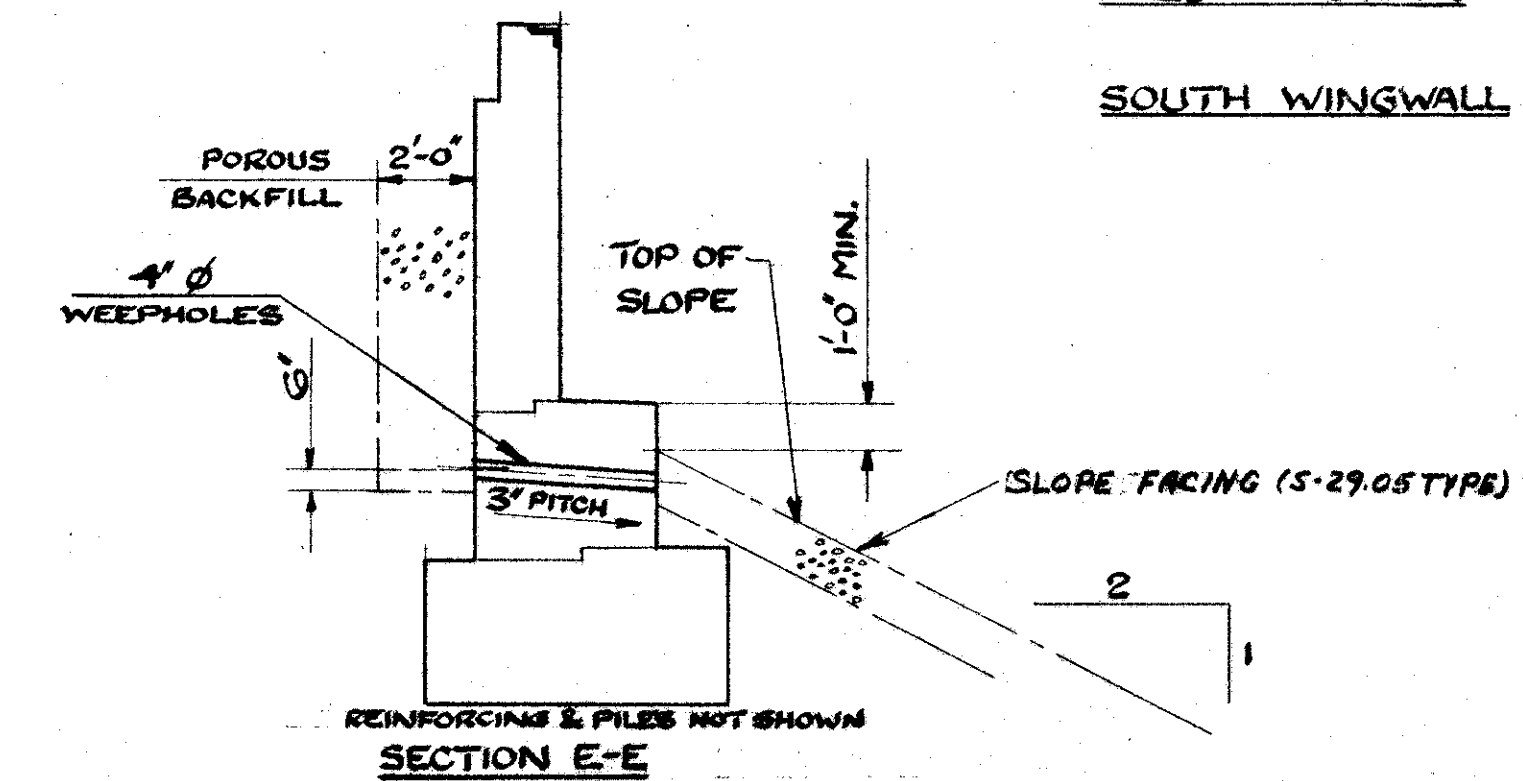

SECTION E-E

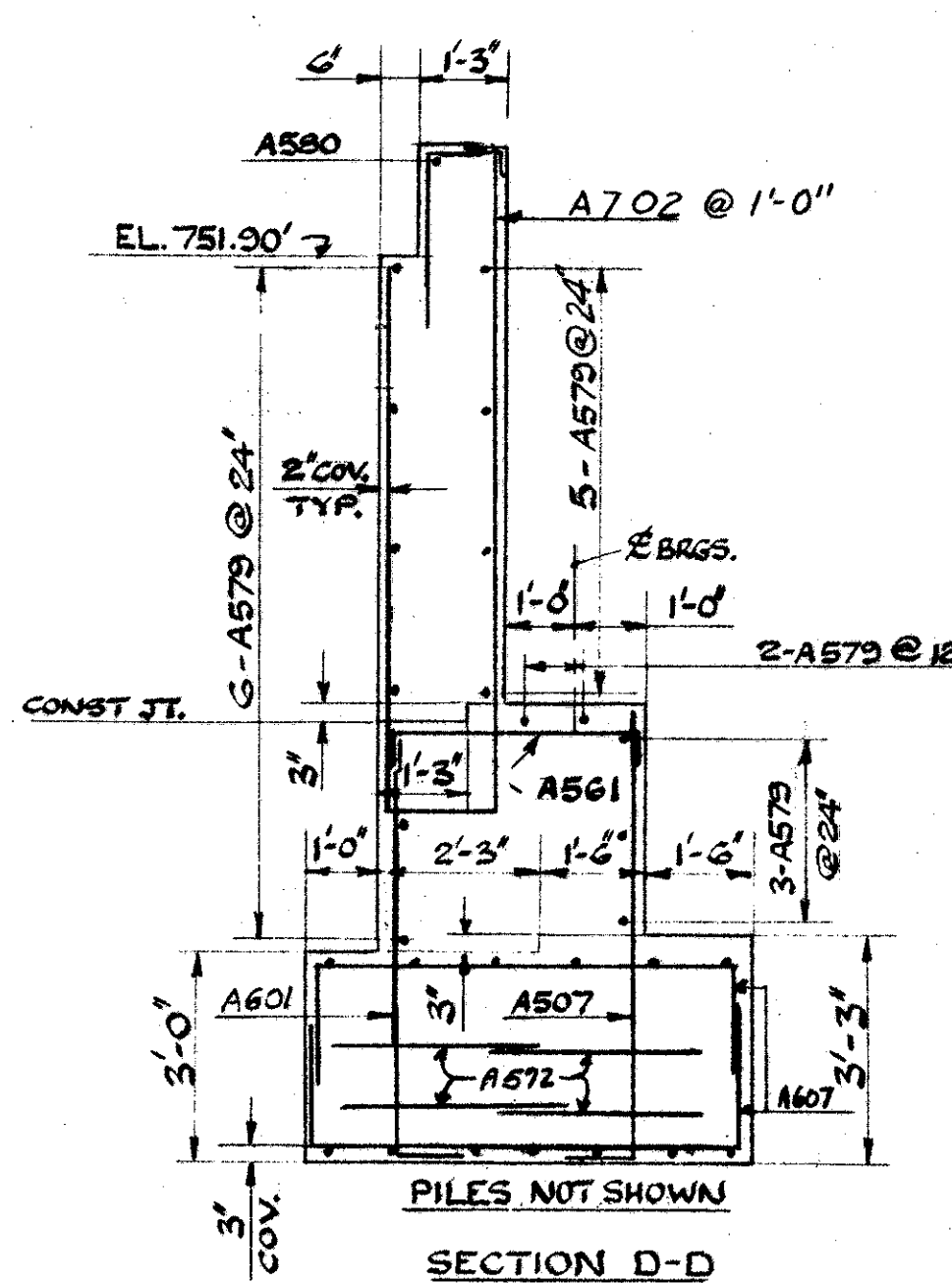

SECTION D-D

SPACING FOR BARS A507,
A601 & A607 SHOWN ON
SHEET 457

SEC. C-32 F.E.D. AID PROJ. AC I-1103(21)

PREPARED BY
CAPITOL ENGINEERING ASSOCIATES, DILLSBURG, PA.
FOR

STATE OF OHIO
DEPARTMENT OF HIGHWAYS

EAST ABUTMENT DETAILS
BRIDGE NO. LAK-1-1542
S.R.1 OVER BIG CREEK
LAKE COUNTY
STA. 461+90.00

DESIGNED	DRAWN	TRACED	CHECKED	REVIEWED DATE	REVISED
R.A.W.	C.T.B.		R.A.W.		