

I:\PROJECTS\PI\22610\22610gya.dgn 14-AUG-2001 9:31AM jgrmovse

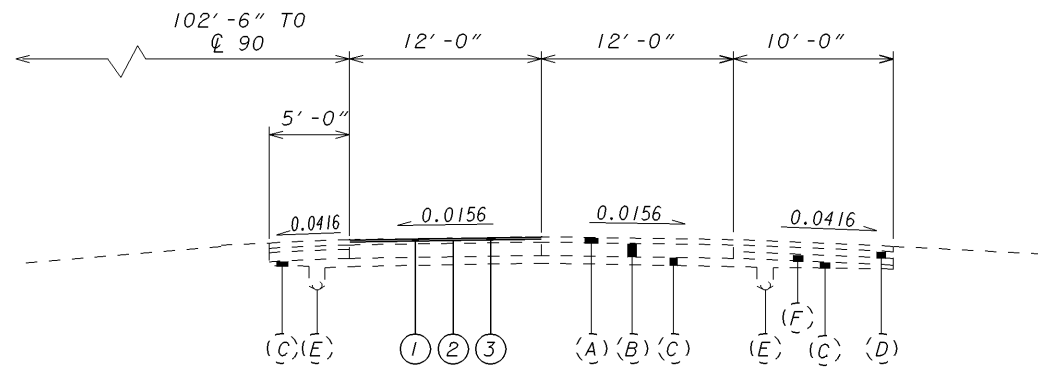

2 LANE NORMAL SECTION
 SLM 12.4 TO 14.63
 (FOR LEFT LANES
 MIRROR ABOUT CL)

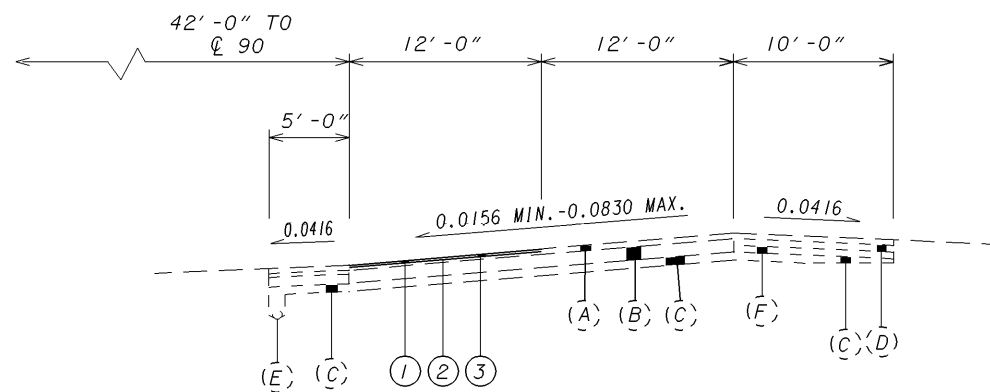

2 LANE SUPERELEVATED SECTION
 SLM 19.62 TO 20.57
 (FOR LEFT LANES
 MIRROR ABOUT CL)

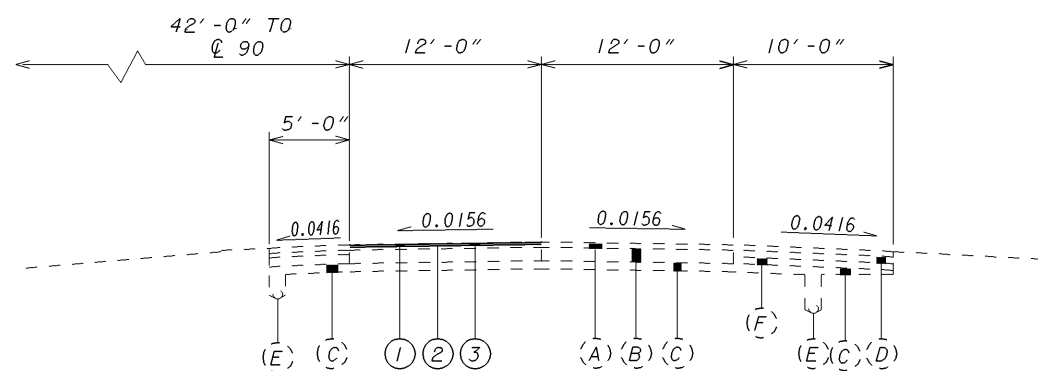

2 LANE NORMAL SECTION
 SLM 14.63 TO 19.62
 SLM 20.57 TO 29.88
 (FOR LEFT LANES
 MIRROR ABOUT CL)

LEGEND

PROPOSED

- (1) ITEM 254 - PAVEMENT PLANING, BITUMINOUS (1 1/2")
- (2) ITEM 407 - TACK COAT
- (3) ITEM 448 - 1-1/2" ASPHALT CONCRETE SURFACE COURSE, TYPE 1H, AS PER PLAN

EXISTING

- (A) ASPHALT OVERLAY (3"±)
- (B) 10" REINFORCED CONCRETE BASE
- (C) SUBBASE
- (D) BIT. AGGREGATE BASE OR AGGREGATE BASE
- (E) UNDERDRAIN
- (F) AGGREGATE BASE

