

PLAN VIEW - TYPICAL COMBINED DRIVEWAY  
AND MAILBOX APPROACH  
NOT TO SCALE

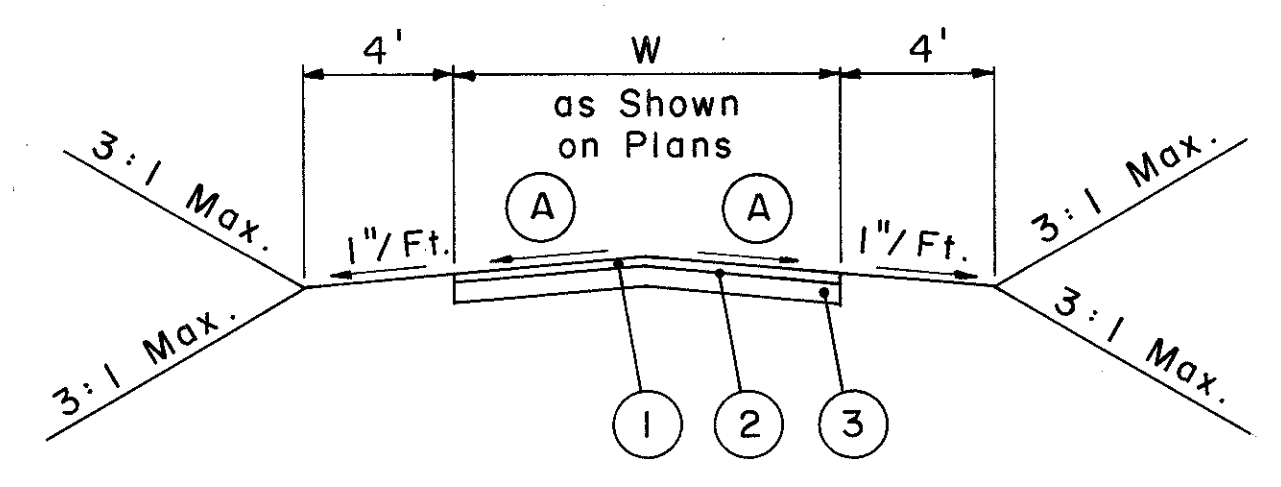

TYPICAL SECTION - DRIVEWAY

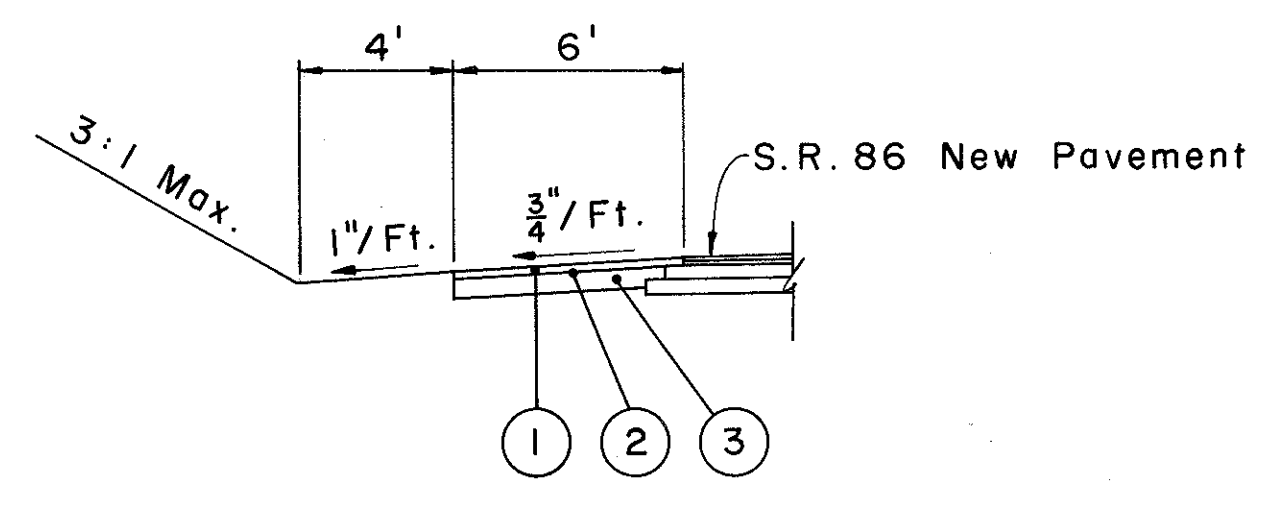

TYPICAL SECTION - MAIL BOX APPROACH  
SECTION A-A

NOTES:

(A) Match Existing End Sections

LEGEND

- (1) Item 404 2" Asphalt Concrete AC-20 Driveways
- (2) Item 408 Bituminous Prime Coat at 0.4 Gal./S.Y.
- (3) Item 304 6" Aggregate Base

STATION	12' LEFT	CL	12' RIGHT	REMARK
6+00	628.61	629.04	629.28	Warp to Meet Existing Pav't.
6+01.18	628.62	629.05	629.29	
6+25	628.67	629.15	629.48	
6+50	628.73	629.27	629.69	
6+67.63	628.76	629.34	629.83	
6+75	628.79	629.39	629.91	Full Super .06 Ft./Ft.
7+00	628.92	629.57	630.18	
7+25	629.11	629.82	630.52	
7+30.63	629.17	629.89	630.61	
7+36.41	629.23	629.95	630.67	
7+42.18	629.31	630.03	630.75	Superelev. Transition
7+50	629.46	630.14	630.82	
7+75	629.98	630.52	631.06	
8+00	630.58	630.97	631.36	
8+05.18	630.71	631.07	631.43	
8+25	631.22	631.47	631.72	Point of R.C.
8+35.37	631.52	631.71	631.90	
8+50	631.87	632.06	632.16	
8+68.18	632.32	632.51	632.51	
8+75	632.49	632.68	632.66	
9+00	633.13	633.32	633.24	Crown Removal
9+25	633.76	633.95	633.81	
9+43.18	634.23	634.42	634.23	
10+64	637.30	637.49	637.30	Crown Removal
10+75	637.60	637.76	637.57	
11+00	638.30	638.40	638.21	
11+25	639.00	639.03	638.84	
11+39	639.39	639.39	639.20	
11+50	639.73	639.67	639.48	Point of R.C.
11+71.81	640.41	640.22	640.03	
11+75	640.51	640.30	640.09	
11+83	640.76	640.51	640.26	
12+00	641.29	640.94	640.59	
12+02	641.35	640.99	640.63	Superelevation Transition
12+25	642.10	641.61	641.12	
12+50	643.00	642.37	641.74	
12+65	643.59	642.87	642.15	
12+75	643.93	643.21	642.49	
13+00	644.85	644.13	643.41	Full Super .06 Ft./Ft.
13+25	645.85	645.13	644.41	
13+50	646.94	646.22	645.50	
13+75	648.11	647.39	646.67	
14+00	649.35	648.63	647.91	
14+25	650.69	649.97	649.25	Warp to Meet Existing Pav't.
14+34.97	651.24	650.52	649.80	
14+50	651.93	651.37	650.68	
14+75	653.16	652.87	652.24	
14+97.97	654.35	654.31	653.73	