

NOTES

POSTS: Posts may be round (standard single rail only) or 150x200 mm square-sawn pressure-treated wood or W150x13.5 galvanized steel. The same type post shall be used throughout the length of the project unless otherwise required by the plans or permitted by the Engineer. Round posts shall be 200 mm ± 25 mm in diameter at the top and not more than 75 mm larger at the butt with a uniform taper. Post may be set in drilled holes or may be driven to grade.

Wood posts shall be fabricated with square ends. Posts and blockouts shall be pressure-treated per CMS 710.14. Bolt holes shall be bored and the tops of posts shall be trimmed as shown, if required, after posts are set.

ALTERNATE BLOCKOUTS: Approved plastic blockouts may be used in lieu of the wood blockouts shown. The approved list is maintained by the Office of Materials Management.

WASHERS: Standard galvanized steel washers of the appropriate size shall be installed on the nut side of bolts through wood posts.

WELDED BEAMS: Welded beam guardrail posts may be used for Item 606, Guardrail, provided the web and flange sizes are as shown hereon. Welding of the web to the flanges shall conform to ASTM A 769M, Class 1 using Grade 36 steel (250 MPa yield point) with the following exceptions:

- Sec. 7.2 Test reports of tensile properties for each lot shall accompany each shipment.
- Sec. 12 Beams that have imperfections repaired by welding shall not be accepted for use in Item 606.
- Sec. 13 Random samples shall be tested by the Department from materials delivered to the project site or other locations designated by the Laboratory.

*** POST EMBEDMENT DEPTH:** For specific depth requirements, see SCD GR-1.2M.

| STEEL BEAM POSTS | | | | |
|------------------|------------|--------------|------------------|---------------|
| Size | Beam depth | Flange width | Flange thickness | Web thickness |
| Rolled W150x12.6 | 148 mm | 100 mm | 4.9 mm | 4.3 mm |
| Rolled W150x13.5 | 150 mm | 100 mm | 5.5 mm | 4.3 mm |
| Welded 150x12.6 | 152 mm | 100 mm | 4.9 mm | 4.3 mm |
| Welded 150x13.5 | 152 mm | 100 mm | 5.5 mm | 4.3 mm |

MISCELLANEOUS: For details not shown see SCD's GR-1.1M and GR-1.2M.

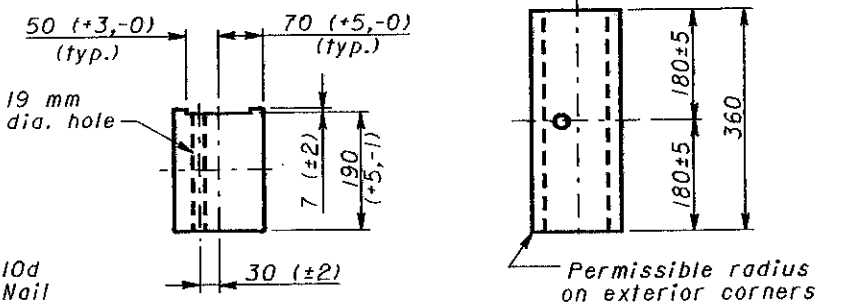

PLAN ELEVATION
NOTCHED BLOCKOUTS FOR STEEL POSTS

OHIO DEPARTMENT OF TRANSPORTATION

**GUARDRAIL
TYPE 5 & 5A**

DATE
11-30-94
10-21-97
4-14-98

STANDARD
CONSTRUCTION
DRAWING
GR-2.1M

APPROVED *Larry T. ...*

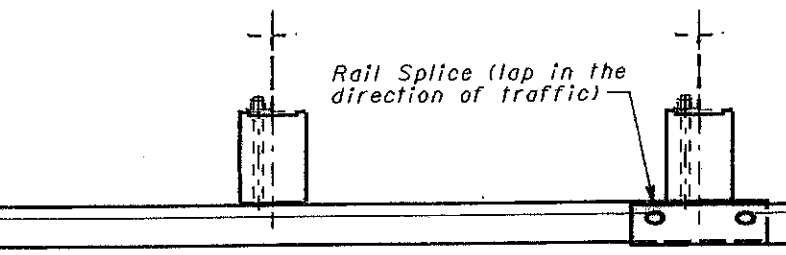

PLAN VIEW (Steel Posts shown)

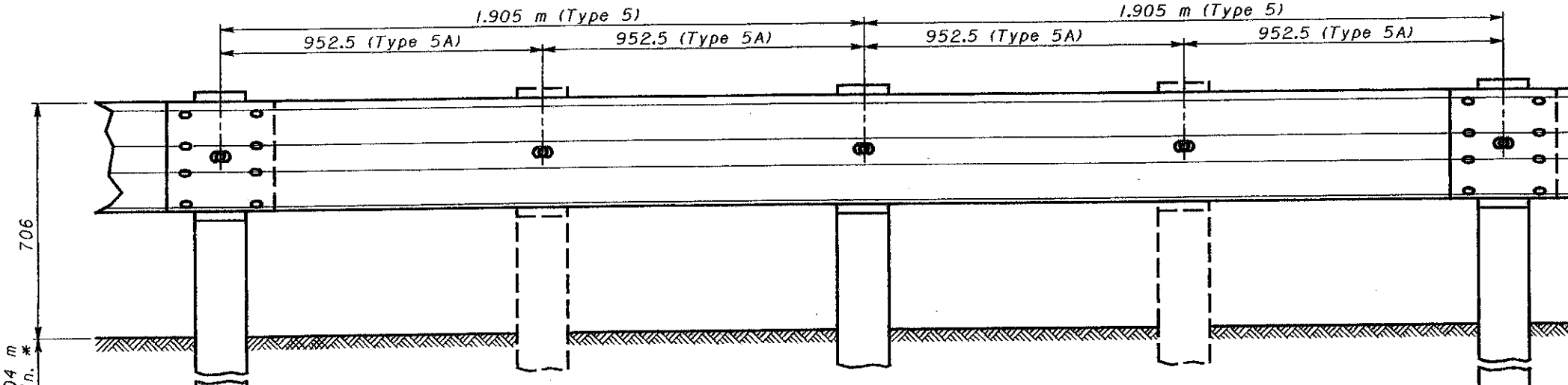

ELEVATION (Wood Posts shown)

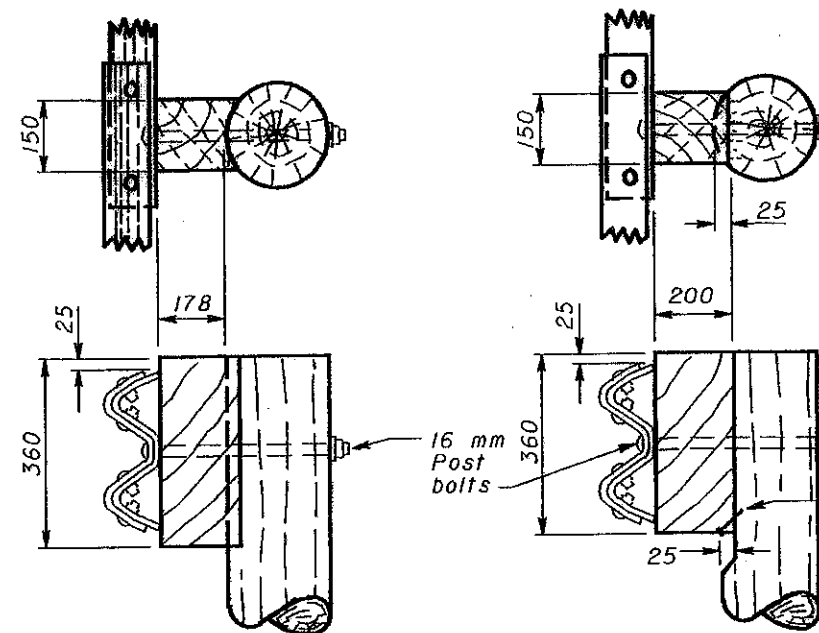
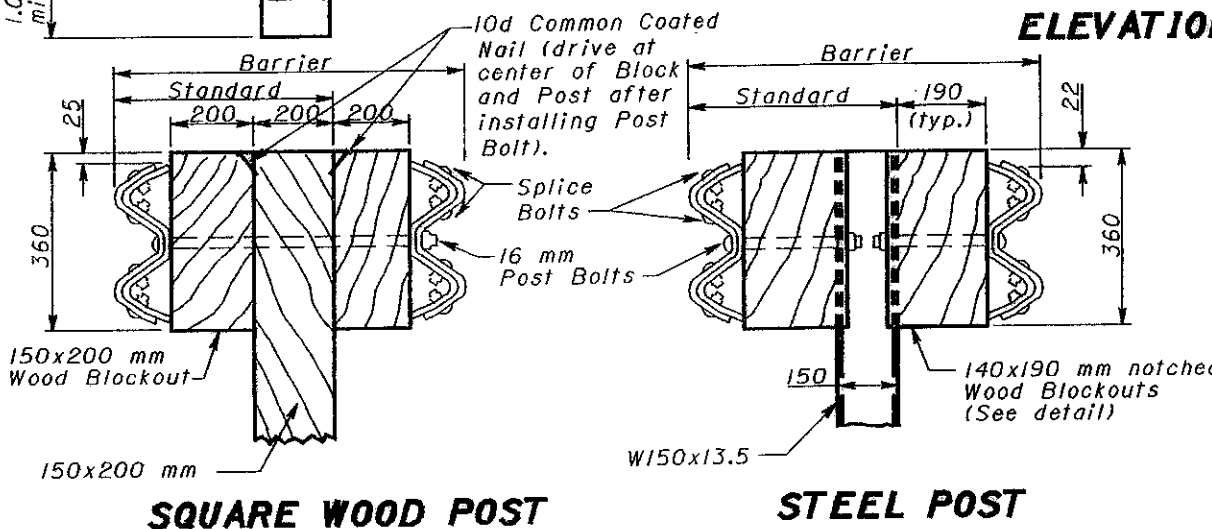

METHOD 1 METHOD 2

Alternate methods of placing the blockouts on round posts may be submitted for consideration and approved by the Engineer.

ROUND WOOD POSTS

All dimensions are in millimeters unless otherwise noted.

Installation of posts and blockouts shall be at 952.5 mm c/c when Type 5A guardrail is specified.

Notched Wood Blockout

Rail Splice (lap in the direction of traffic)

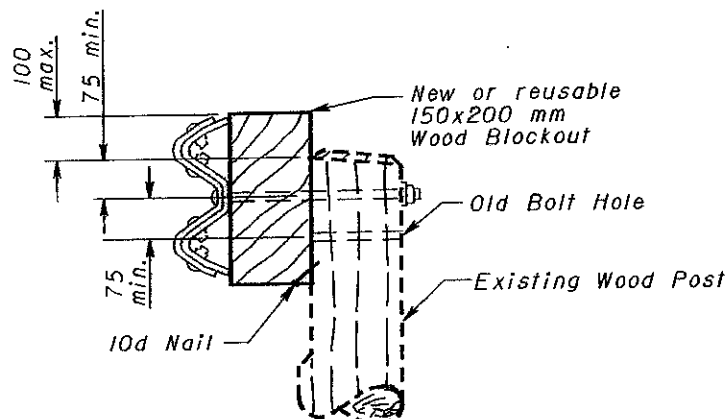

WOOD POSTS WITH WOOD BLOCK
RAISING EXISTING GUARDRAIL HEIGHT