

DRIVEWAY APRON DETAIL

SEE STD. DWG. BP-4.1 FOR ADDITIONAL DETAILS

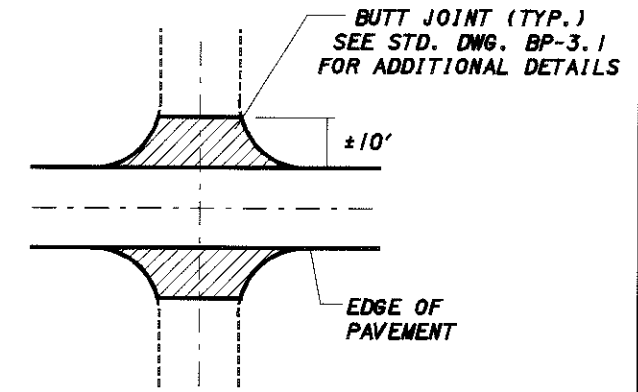

TYPICAL INTERSECTION DETAIL

PAVEMENT REPAIR QUANTITIES

ROUTE	LOG POINT TO LOG POINT	LENGTH		TYPICAL	WP	PAVEMENT AREA SQ. YD.	203	448	407	448	254	254	407	301
		EXCAVATION NOT INCLUDING EMBANKMENT CONSTRUCTION CU. YD.	ASPHALT CONCRETE INTERMEDIATE COURSE, TYPE 1 PG 64-22 (0"-1/2") CU. YD.				TACK COAT FOR INTERMEDIATE COURSE @ 0.05 GAL/SQ. YD.	ASPHALT CONCRETE SURFACE COURSE, TYPE 1, PG 76-22 (1 1/2") CU. YD.	PAVEMENT PLANING BITUMINOUS, AS PER PLAN, 1" SQ. YD.	PAVEMENT PLANING BITUMINOUS, AS PER PLAN, 2" SQ. YD.	TACK COAT @ 0.10 GAL/SQYD GALLON	BITUMINOUS AGGREGATE BASE, PG 64-22 CONSTRUCTION CU. YD.		
		MILE	FT.		FT.									
PART I														
SR 84	19.11 TO 19.13	0.02	106	1	28	330		5	17	14		330	33	
	19.13 TO 19.26	0.13	687	2	26	1985		28	99	83		1985	199	
	19.26 TO 19.75	0.49	2588	3&4	28	8052		112	403	336		8052	805	
	19.75 TO 21.54	1.79	9452	5	24	25203		350	1260	1050	25203		2520	
	19.75 TO 21.54	1.79	9452	5	2+2	4200	700							700
INTERSECTIONS						320		5	16	13	160	160	32	
RIVERSIDE DR. INTERSECTION						780		11	39	33		780	78	
TOTALS CARRIED TO GENERAL SUMMARY							700	511	1834	1529	25363	11307	3667	700

PLOTTED FROM: I:\PROJECTS\19121505\21505.dwg