

SECTION A-A SECTION B-B

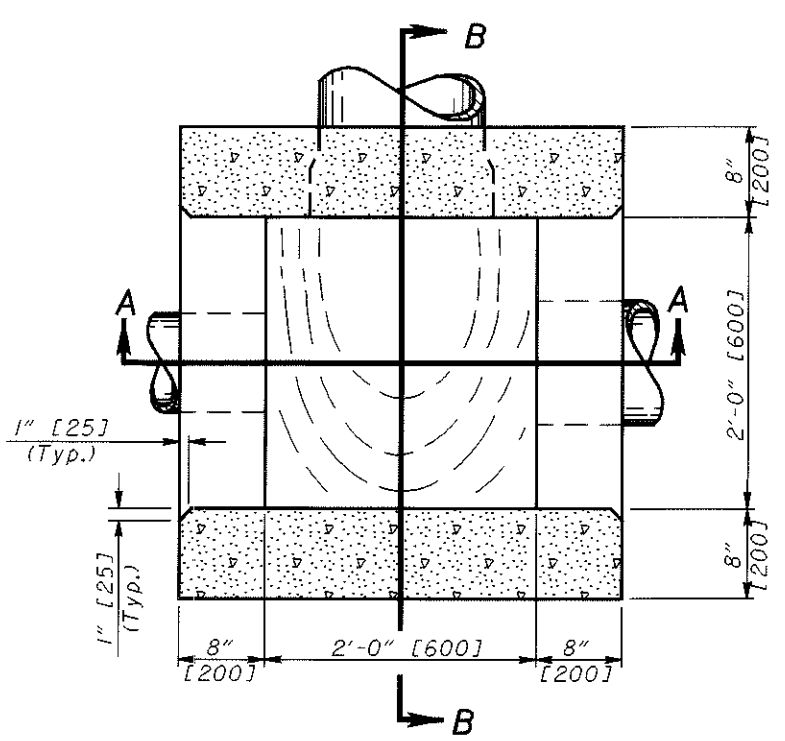

SECTION C-C

All grate edges to be rounded 1/4\" [6] radii

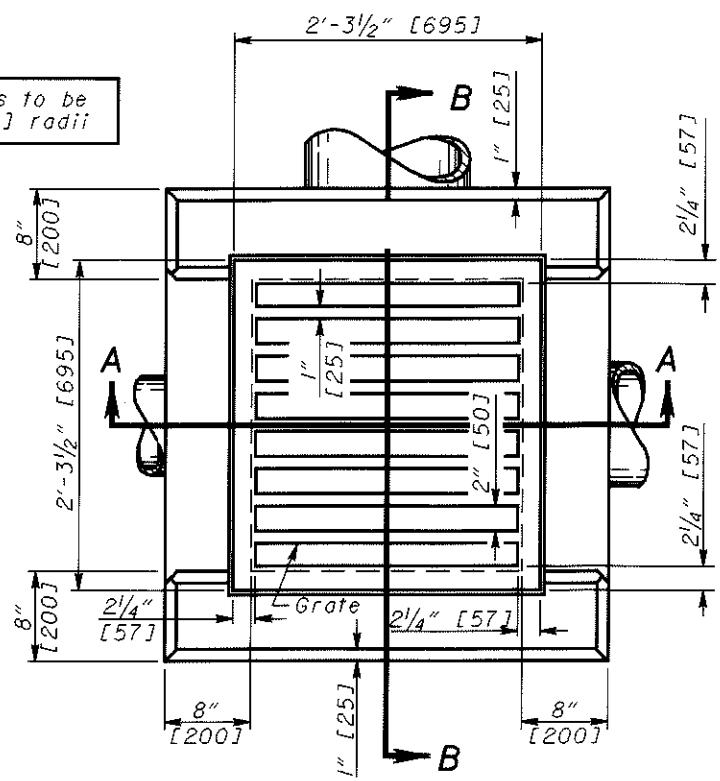

PLAN

NOTES

CATCH BASINS 2-2A & B: This sheet depicts Catch Basin 2-2A. See Sheet 2 of 2 for Catch Basin 2-2B.

GRATE AND FRAME: The design shall be essentially the same and equally as strong as the one shown (see construction information table), or meets AASHTO M 306.

WALLS: Brick or cast-in-place walls have a nominal thickness of 8\" [200]. Precast walls shall have a minimum thickness of 6\" [150] and be reinforced sufficiently to permit shipping and handling without damage. Brick shall not be used above the flow line of the side opening for Type 2-2A.

CONCRETE: Cast-in-place concrete is to be Class C. All precast concrete shall meet the requirements of CMS 706.13 with a minimum of 4% entrained air in the hardened concrete and be marked with the catch basin number.

PRECAST BASE: If a precast base is used, it shall be set deep enough so that the top can be placed on the base to provide the grate elevation specified in the plans. Layers of brick shall not be used to adjust the top elevation.

LOCATION AND ELEVATION: When given on the plans, location and elevation are at the top center of the grate. When side openings are provided, the elevation shall be at the flow line of the side inlet.

MINIMUM DEPTH: The minimum depth of CB No. 2-2A shall be the outside diameter (O.D.) of the outlet pipe plus 7\" [175].

OPENINGS: Pipe openings shall be the O.D. of the pipe being supplied plus 2\" [50] when fabricated or field cut. The interstitial space shall be filled with grout per CMS 601.

2-2A SIDE INLETS: Inlets shall be provided on both sides of the No. 2-2A catch basin in sags and on upstream side only where the ditch has a continuous down grade past the catch basin. Side inlets shall not be used within the Clear Zone. The flow line should be 4\" to 6\" [100 to 150] below the normal elevation of the ditch flow line, returning to normal within 10' to 15' [3 m to 5 m] of the basin.

PAYMENT: All materials and labor, including excavation and backfilling, shall be paid for under **Item 604 - Catch Basin, No. 2-2A.**

CONSTRUCTION INFORMATION	
Minimum weight [mass] of grate,	120 lbs. [54 kg]
Minimum weight [mass] of frame,	40 lbs. [18 kg]

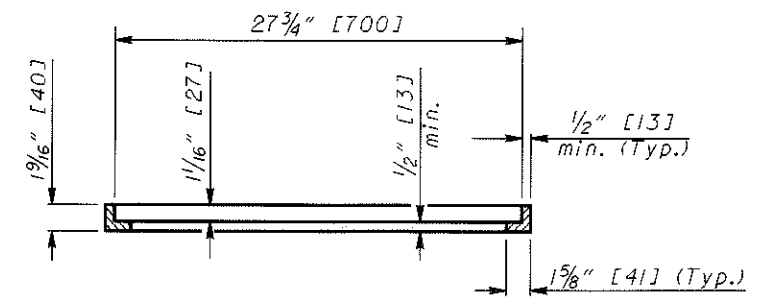

SECTION THRU ANGLE FRAME FOR STANDARD No. 2-2A CATCH BASIN

CATCH BASIN No. 2-2A

THIS DRAWING REPLACES CB-1.I.M DATED 7-12-95.

OHIO DEPARTMENT OF TRANSPORTATION	DATE
ROADWAY DESIGN ENGINEER	7-20-01
REVISIONS	
STOS. ENGR.	D. Focke
DRAWN	D. Focke
All metric dimensions (in brackets []) are in millimeters unless otherwise noted.	
ROADWAY ENGINEERING SERVICES	
STANDARD ROADWAY CONSTRUCTION DRAWING	
CATCH BASINS No's 2-2A & B	
NUMBER	CB-1.I
	1/2