

POST A

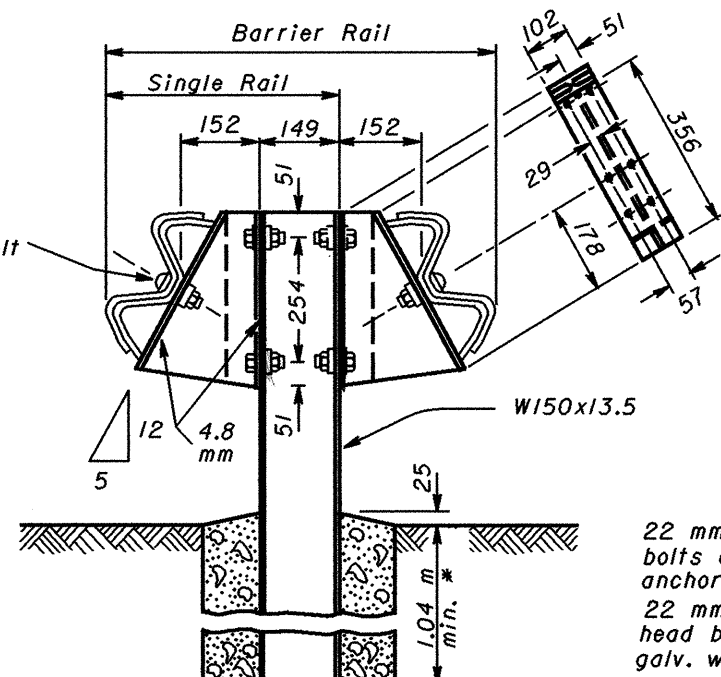

POST B

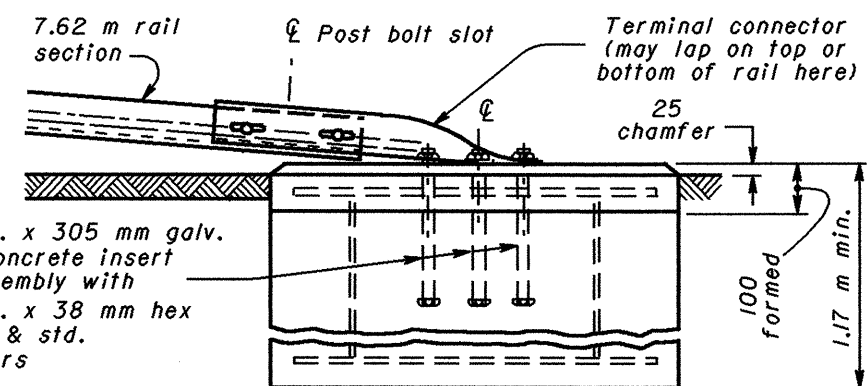

CONCRETE ANCHOR

22 mm dia. x 305 mm galv. bolts or concrete insert anchor assembly with 22 mm dia. x 38 mm hex head bolts & std. galv. washers

NOTES

GENERAL: For details not shown, see Std. Constr. Dwgs. GR-1.1M, GR-1.2M and other Drawings pertaining to specific guardrail type. All steel parts shall be galvanized.

The 460 mm flare offset from normal face of rail, shown in the plan view (for single rail installations), will be utilized only where shoulder width is insufficient for providing standard offsets.

SPACERS: Post B spacers shall be made of 4.8 mm steel plate as per CMS 710.15 or two sections of W150x13.5 or W200x15.0 cut in the web (see dashed line) and welded together on both sides.

All steel spacers and posts may be provided with additional bolt holes so that these items will not be required to be made right and left handed.

Spacers shall be fastened to their posts with two 16 mm hexhead bolts and nuts with standard washers on both sides.

WASHERS: All washers indicated on this drawing are standard galvanized steel of the appropriate size.

CONCRETE ANCHOR: Form top 100 mm of anchor and slope the top to conform to slope of the adjacent ground. The 915 mm diameter anchor may be replaced by a 760 mm square anchor at the contractor's option.

POST A: Rail details are shown for Type 5 guardrail. Where anchor assembly is attached to Type 4 guardrail, Post A shall be a standard Type 4 line post set in concrete, and the spacer block shall be omitted. Post bolt shall be 16 mm in diameter.

*** SINGLE RAIL INSTALLATIONS:** See GR-1.2M for additional post embedment details.

All dimensions are in millimeters unless otherwise noted.



BUREAU OF LOCATION AND DESIGN OHIO DEPARTMENT OF TRANSPORTATION	
TYPE A ANCHOR ASSEMBLY	DATE 11-30-94
STANDARD CONSTRUCTION DRAWING GR-4.1M	
APPROVED <i>D.K. Hulman</i>	ENGR., L & D