

SECTION A-A
LAMINATED ELASTOMERIC EXPANSION BEARING AT PIER 1

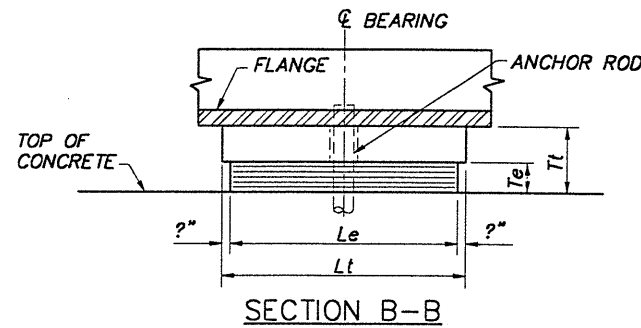

SECTION B-B
LAMINATED ELASTOMERIC FIXED BEARING AT PIER 2

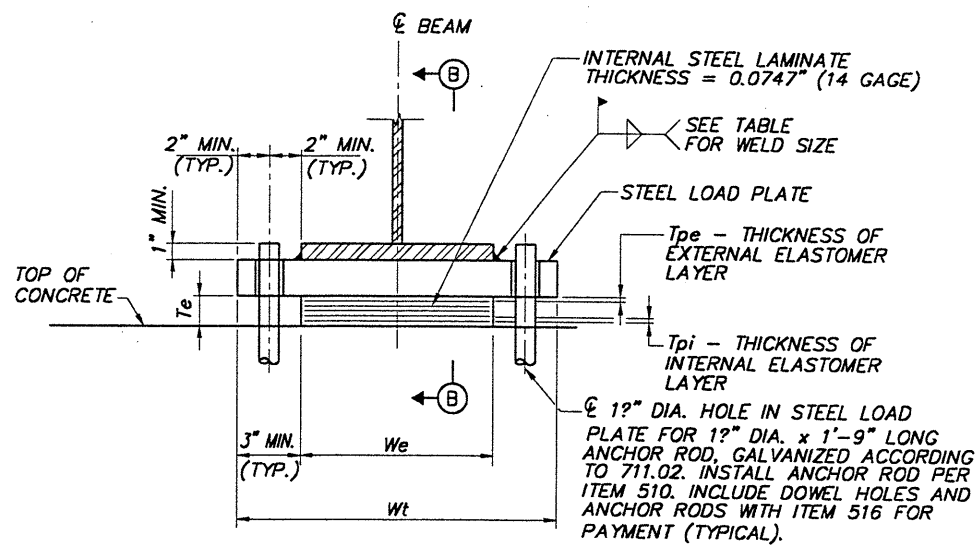
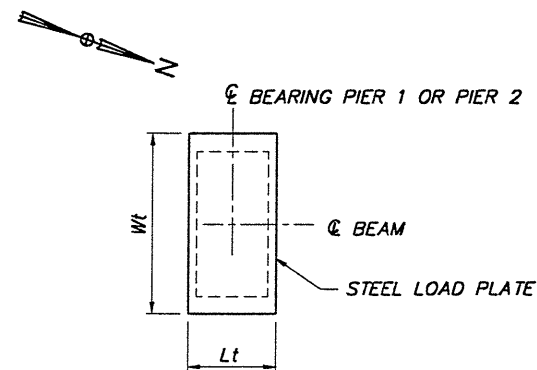

BEARING ORIENTATION PLAN

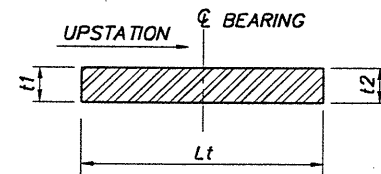

STEEL LOAD PLATE

NOTES

- ELASTOMERIC BEARINGS SHALL COMPLY WITH ITEM 516 AND SECTION 18 "BEARINGS" (DIVISION II-CONSTRUCTION) OF THE AASHTO "STANDARD SPECIFICATIONS FOR HIGHWAY BRIDGES" AND THE 1997, 1998 INTERIM REVISIONS.
BEARINGS SHALL BE GRADE 3, 50 DUROMETER ELASTOMER.
THE LAMINATED ELASTOMERIC BEARING MANUFACTURER SHALL SUBJECTED TO THE TESTS DESCRIBED IN ARTICLE 18.7 OF SECTION 18 "BEARINGS" (DIVISION II-CONSTRUCTION) OF THE AASHTO "STANDARD SPECIFICATIONS FOR HIGHWAY BRIDGES" AND THE 1997, 1998 INTERIM REVISIONS.
THE TESTING SHALL BE INCLUDED IN THE UNIT PRICE BID FOR THE BEARINGS.
ACCEPTANCE OF THE BEARING SHALL BE ACCORDING TO ARTICLE 711.23 OF THE O.D.O.T. CONSTRUCTION AND MATERIAL SPECIFICATIONS.
THE MANUFACTURER SHALL FURNISH CERTIFIED TEST DATA AND SHALL SUPPLY A SAMPLE BEARING OF EACH DESIGN, AS SHOWN ON THE PLANS, FOR DESTRUCTIVE TESTING AND APPROVAL PURPOSES.
SAMPLE BEARINGS WILL NOT BE PAID FOR DIRECTLY BUT SHALL BE CONSIDERED INCIDENTAL TO THE ITEM 516.
- WELDING SHALL BE CONTROLLED SO THAT THE PLATE TEMPERATURE AT THE ELASTOMER BONDED SURFACE DOES NOT EXCEED 300° F AS DETERMINED BY THE USE OF PYROMETRIC STICKS OR OTHER TEMPERATURE MONITORING DEVICES.
- BEARING REPOSITIONING: IF THE STEEL IS ERECTED AT AN AMBIENT TEMPERATURE HIGHER THAN 80° F OR LOWER THAN 40° F AND THE BEARING SHEAR DEFLECTION EXCEEDS 1/6 OF THE BEARING HEIGHT AT 60° F (±) 10° F, THE BEAMS SHALL BE RAISED TO ALLOW THE BEARINGS TO RETURN TO THEIR UNDEFORMED SHAPE AT 60° F (±) 10° F.
- THE STEEL LOAD PLATE SHALL BE ASTM A709 GRADE 50 STEEL.
- THE STEEL LOAD PLATE SHALL BE BONDED BY VULCANIZATION TO THE ELASTOMER DURING THE MOLDING PROCESS.
- TOTAL DESIGN LOAD FOR BEARINGS EQUALS THE SUM OF THE DEAD LOADS AND LIVE LOADS TABULATED IN THE BEARING TABLE.
- BEARING ANCHOR RODS: AT THE OPTION OF THE CONTRACTOR, THE BEARING ANCHOR RODS (OR FORMED HOLES), LOCATED AND SUPPORTED BY TEMPLATES, MAY BE CAST-IN-PLACE. IF ANCHOR RODS ARE NOT CAST-IN-PLACE THEY SHALL BE GROUTED IN ACCORDANCE WITH ITEM 510 USING NONSHRINK, NONMETALLIC GROUT MEETING THE REQUIREMENTS OF 705.20.
- ANCHOR RODS SHALL BE GALVANIZED AS PER O.D.O.T. CONSTRUCTION AND MATERIAL SPECIFICATION 711.02. ANCHOR RODS SHALL EXTEND 1 INCH (MINIMUM) ABOVE THE LOAD PLATE (SEE DETAIL).
- BASIS OF PAYMENT: THE UNIT BID PRICE SHALL INCLUDE ALL MATERIALS, LABOR, AND INCIDENTALS NECESSARY TO FURNISH AND INSTALL LAMINATED ELASTOMERIC BEARINGS. SAMPLE BEARINGS SHALL NOT BE MEASURED FOR PAYMENT.

BEARING LOCATION	MARK NO.	BEARING TYPE	NO. REQ'D.	DEAD LOAD KIPS	LIVE LOAD KIPS	TOTAL LOAD (DL+LL) KIPS	Le in.	We in.	Tpi in.	NO. OF Tpi'S	Tpe (2 EA.) in.	NUMBER OF INTERNAL LAMINATES (14 GAGE)	Te in.	STEEL LOAD PLATE, in.				Tt in.	FILLET WELD SIZE
														Lt	Wt	t1	t2		
PIER 1	E1	EXP.	6	70	51	121	9	14	0.26	3	0.19	4	1?	10	15	1?	1?	3?	?
PIER 2	F1	FIXED	6	70	51	121	8?	14	0.23	4	0.16	5	1?	9?	20	1?	1?	3?	?