

STEEL FRAMING PLAN

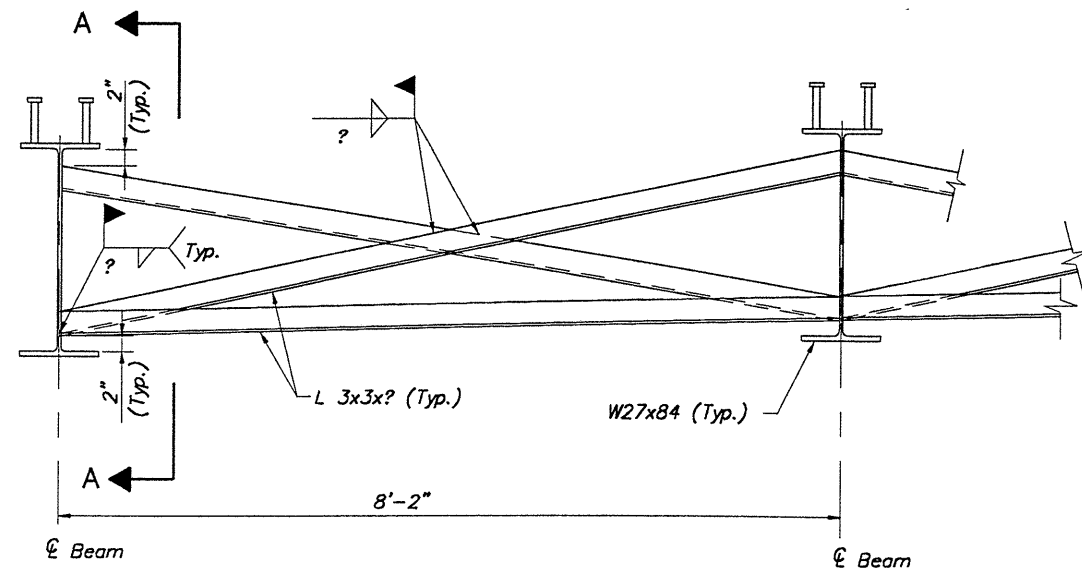

INTERMEDIATE CROSSFRAME DETAIL

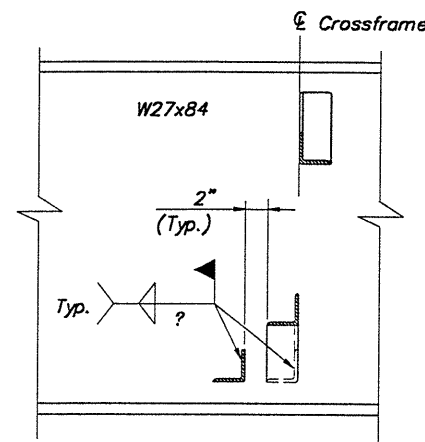

SECTION A-A

- NOTES:
1. For Bridge Transverse Section See Sheet 14/16.
 2. For Beam Elevation, Details and Steel Notes, See Sheet 11/16.
 3. Notation: Brg.-Bearing; Spa.-Spaces; Typ.-Typical.

H:\CT\97260\CAD\97260B22.DWG PLOT SCALE 1:64

<p>CT Consultants, Inc. Engineers, Architects, Planners 1000 Main Street, Suite 1000, Stamford, CT 06901</p>	
DATE	12/30/99
REVIEWED	J.E.A.
STRUCTURE FILE NUMBER	
DRAWN	I.A.S.
REVISOR	I.A.S.
DESIGNED	I.A.S.
CHECKED	J.P.R.
<p>FRAMING PLAN</p> <p>KIRTLAND-CHARLTON ROAD BRIDGE</p> <p>OVER EAST BRANCH CHAGRIN RIVER</p>	
<p>LAK-615-0.00</p>	
<p>10 / 16</p>	
<p>68 / 95</p>	