

MICROFILMED  
JAN 7 1983

|             |       |         |
|-------------|-------|---------|
| FHWA REGION | STATE | PROJECT |
| 5           | OHIO  |         |

25  
32

LAKE COUNTY  
LAK- 608-03.35

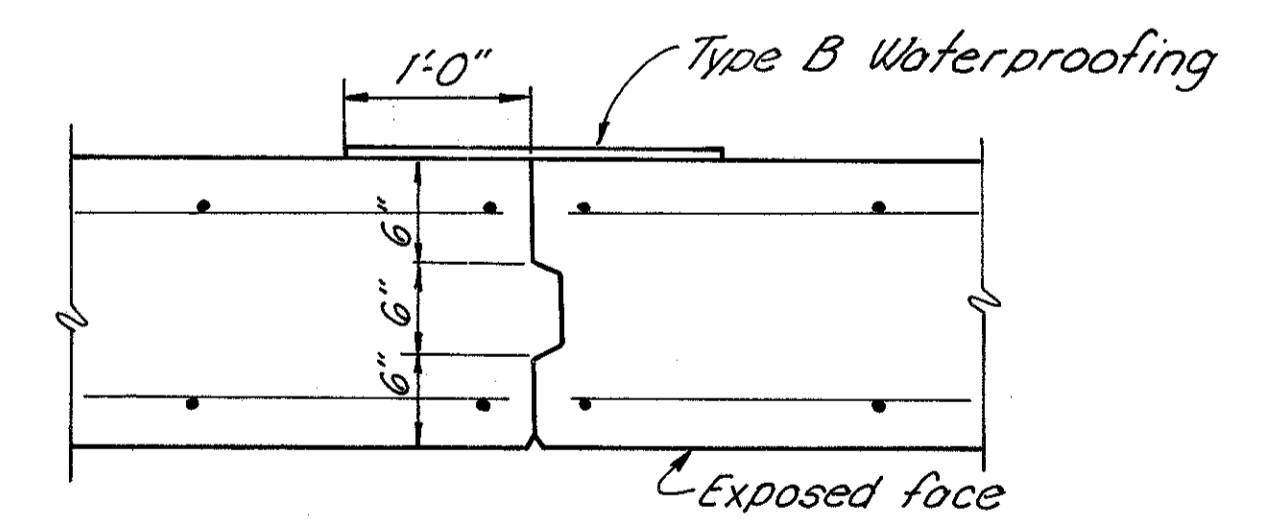
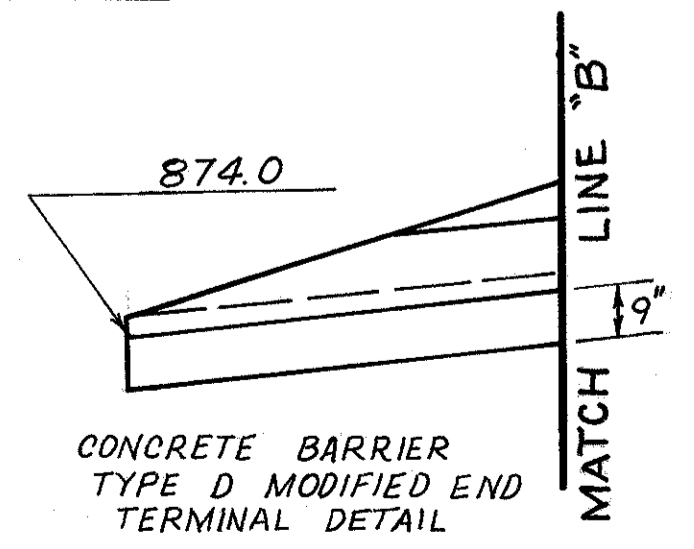
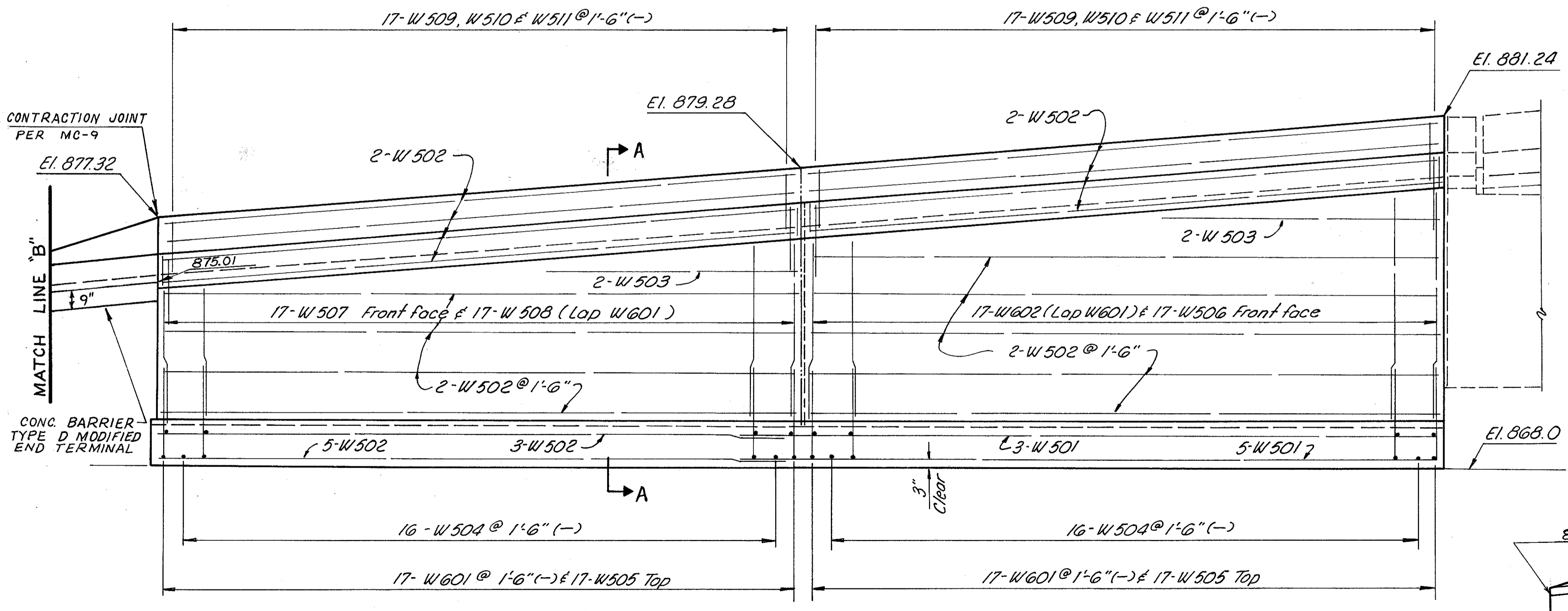
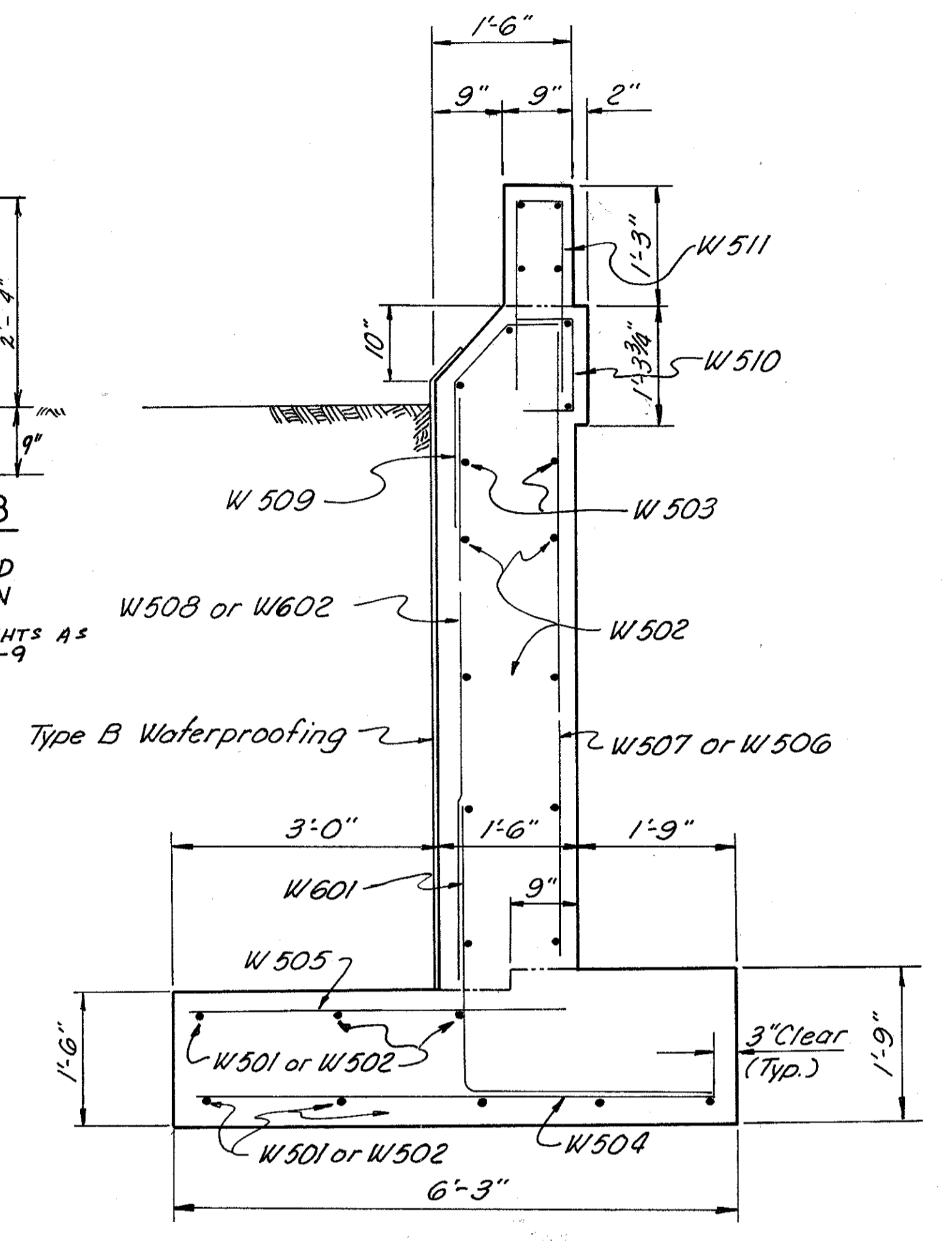
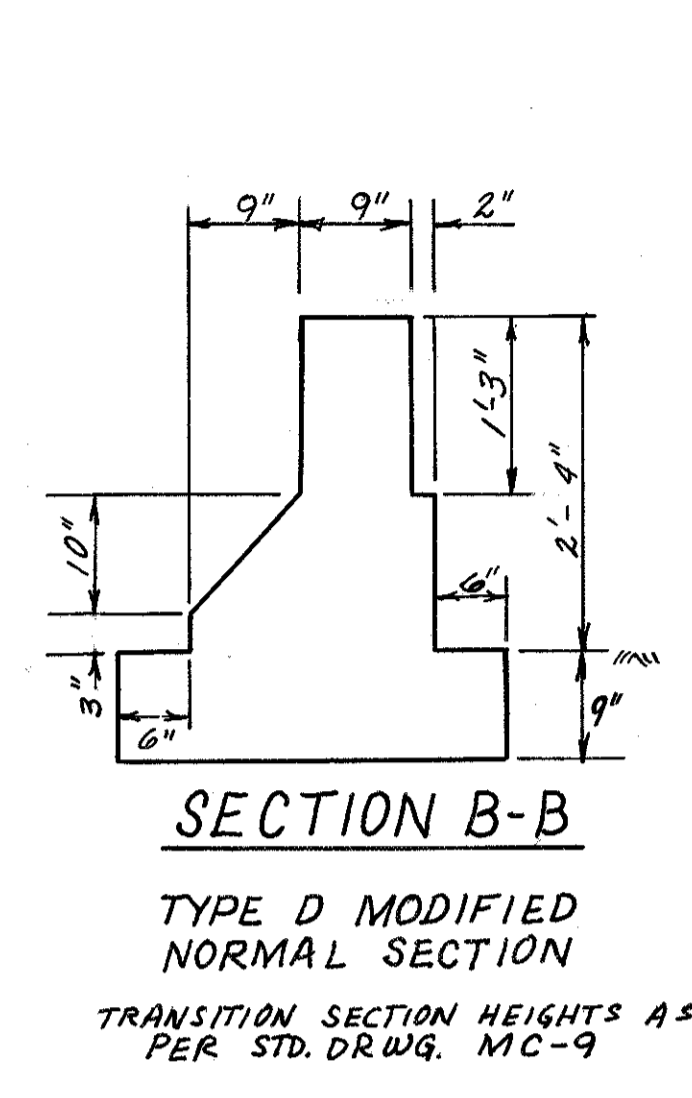
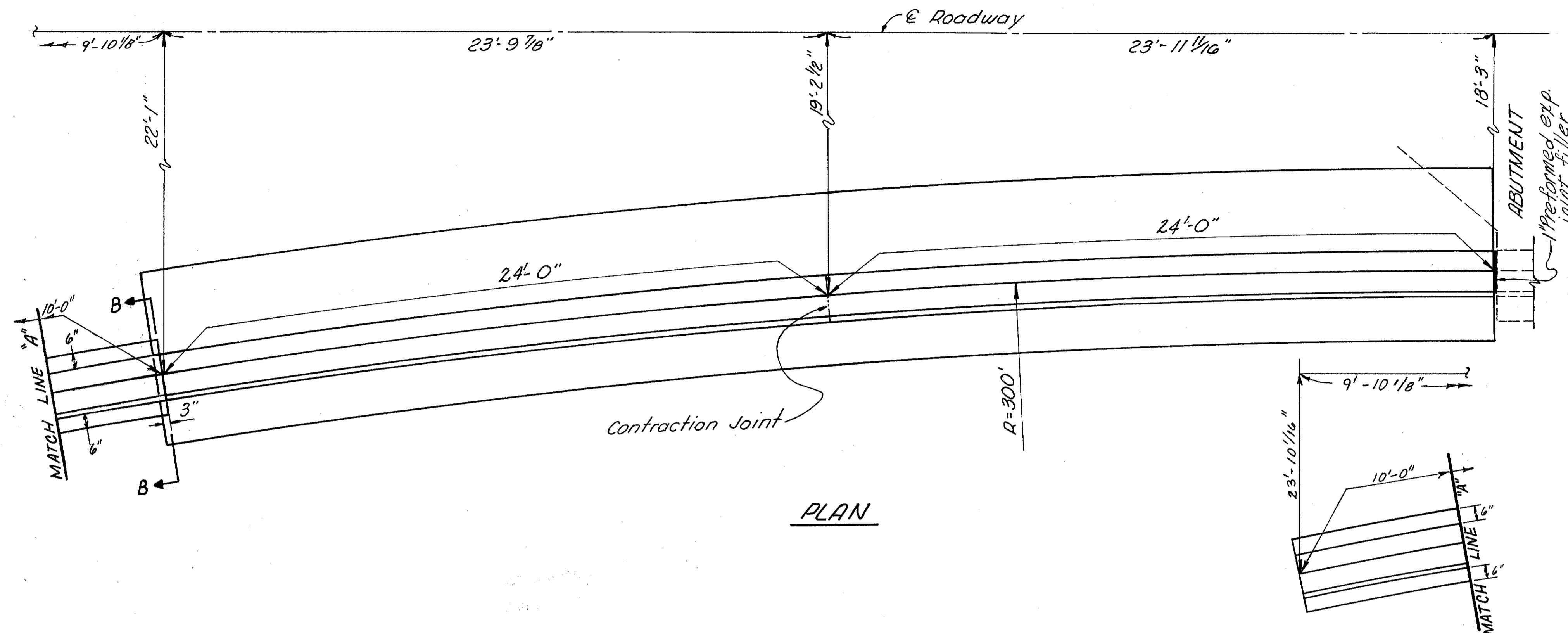

|   |       |         |          |          |         |
|---|-------|---------|----------|----------|---------|
| ERIKSSON ENGINEERING<br>COLUMBUS OHIO   |       |         |          |          |         |
| RETAINING WALL                          |       |         |          |          |         |
| BRIDGE NO LAK- 608-0337                 |       |         |          |          |         |
| S.R. 608 OVER CHESSIE SYSTEM            |       |         |          |          |         |
| LAKE CO. STA. 48+94.09 to STA. 51+12.85 |       |         |          |          |         |
| Designed                                | Drawn | Checked | Reviewed | Date     | Revised |
| V.K.                                    | J.K.  | C.E.    | tel      | 11/14/77 |         |