

NOTES

GENERAL: This drawing shows alternate types of curb that may be used on various types of pavement. Typical section of project shows the type to be used, also the thickness of the edge of the pavement or the edge of the curb and gutter section.

JOINTS: 25 mm expansion joints shall extend up to the top of the curb and shall be constructed in the curb and gutter section in such a manner that the joint seal will extend the full width of the gutter and into the curb face a sufficient distance to seal the joint to an elevation of at least 50 mm above the flow line of the gutter. Dowel bars shall be used in the curb and gutter section at expansion joints which are identical with the joints in the pavement. All joints shall be constructed perpendicular to the edge of the curb and to the surface of the pavement.

Transverse expansion joint material shall meet the requirements of Item 705.03.

GUTTER PLATE THICKNESS: Thickness of gutter plate "T" shall be 230 mm unless otherwise shown on the plans.

TOLERANCES: Dimensional tolerances are as follows:
Curbs: -1 to +5 mm, Gutters 0 to +12 mm.

* Expansion joint material and joint sealer is not required for that portion of the curb which is adjacent to a flexible type pavement. Both materials are required as detailed for the full height of rigid pavement and concrete bases.

⊕ Butt joints shall be provided between combined curb-and-gutter and new or existing rigid pavements, with tie bars or hook bolts provided at intervals of 1.5 m. See Std. Constr. Dwg. BP-2.1M for details of tie bars and hook bolts.

If the combined curb-and-gutter adjoins a new rigid base or an existing rigid base or pavement that is to be surfaced with bituminous material, a butt joint shall also be provided. However, tie bars or hook bolts shall be omitted when the vertical overlap ("V" in detail below) between the curb-and-gutter and rigid pavement is less than 175 mm.

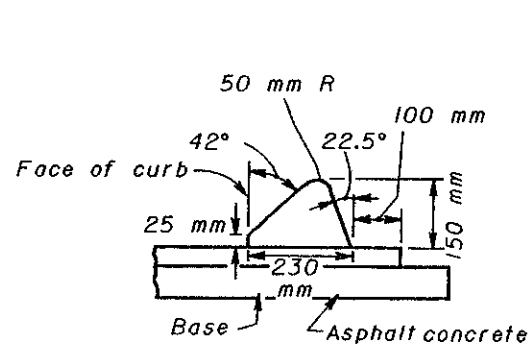

TYPE 1

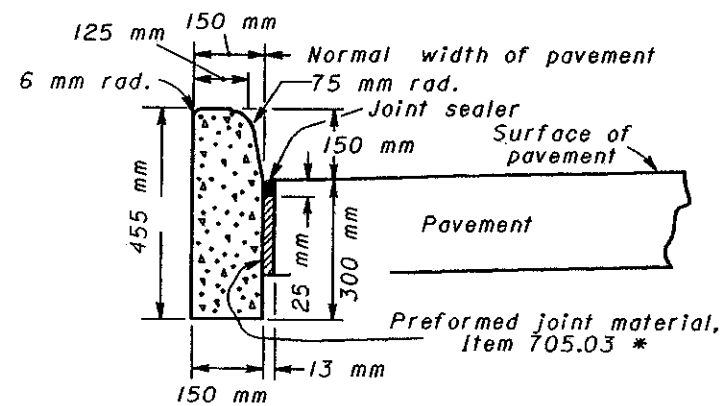

TYPE 6

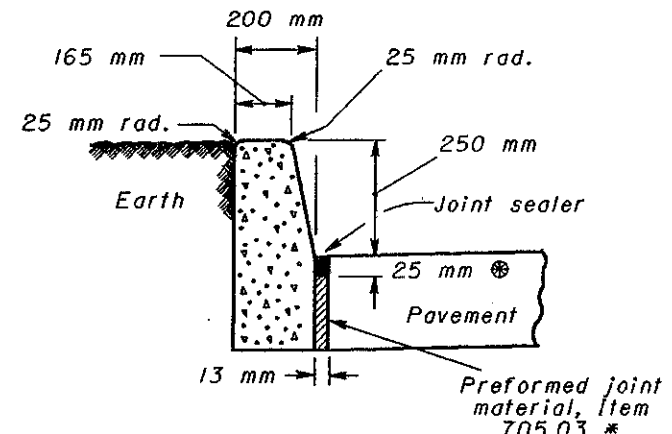

TYPE 7

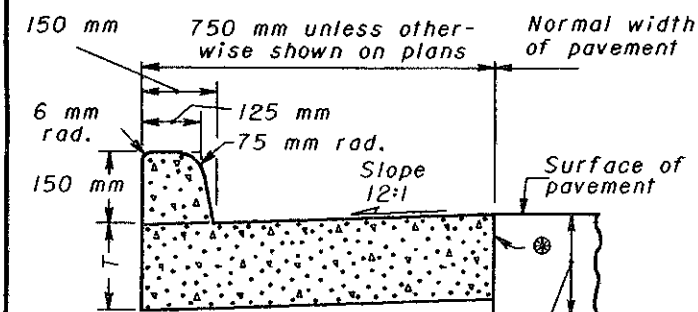

As shown on Typical Sections in plans

TYPE 2

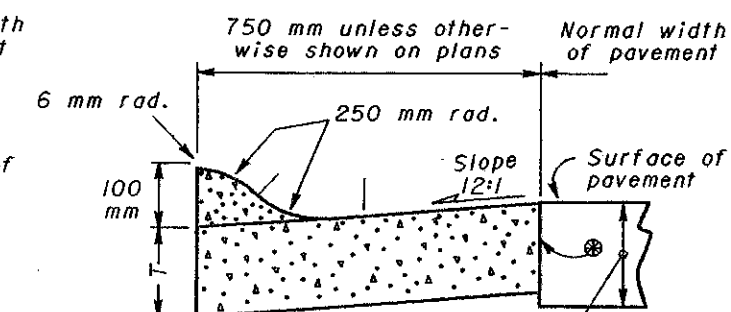

As shown on Typical Sections in plans

TYPE 3

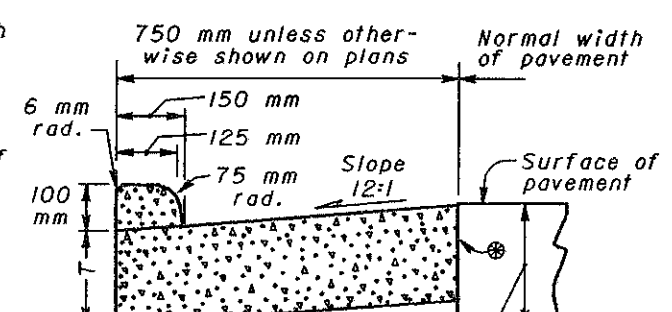

As shown on Typical Sections in plans

TYPE 4

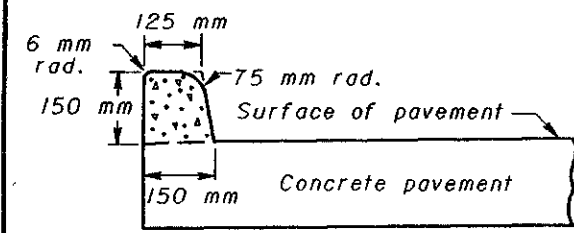
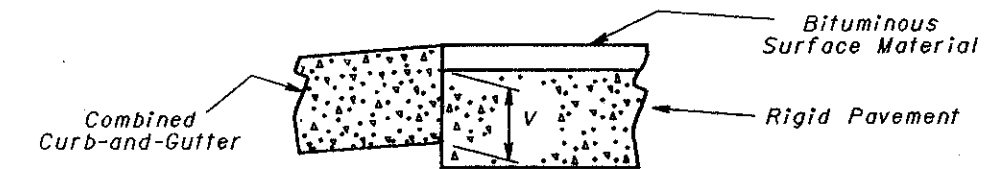

TYPE 2-A

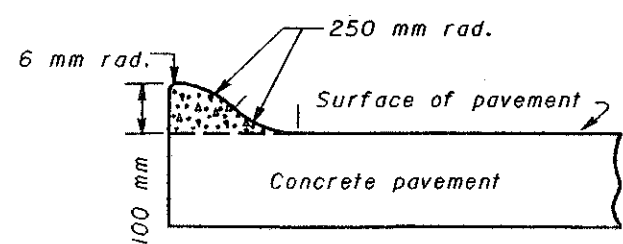

TYPE 3-A

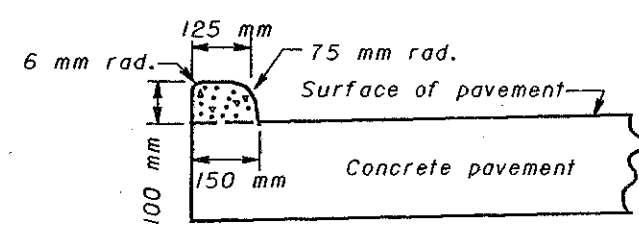

TYPE 4-A

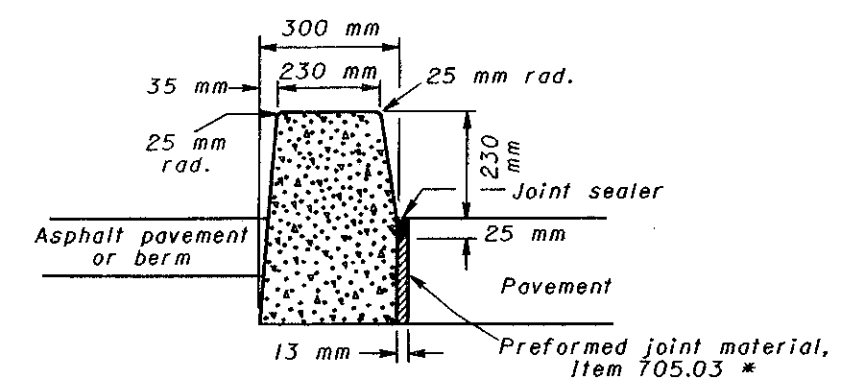

TYPE 8

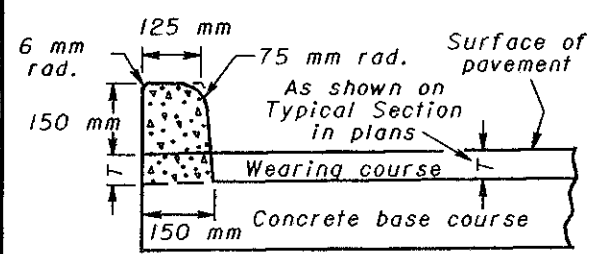

TYPE 2-B

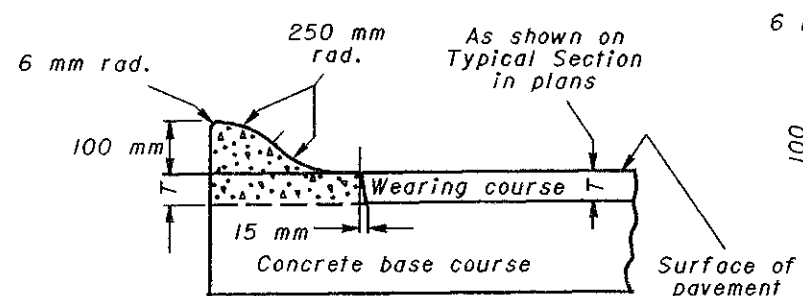

TYPE 3-B

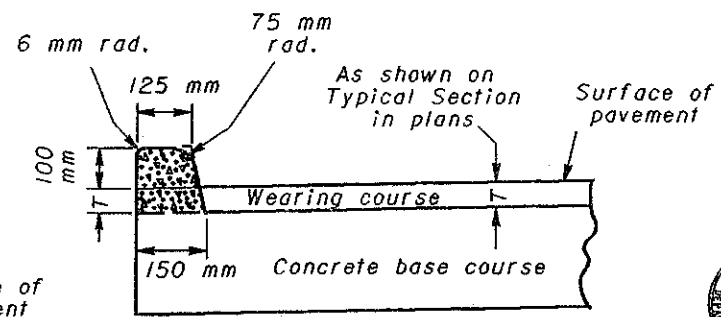

TYPE 4-B



BUREAU OF LOCATION AND DESIGN OHIO DEPARTMENT OF TRANSPORTATION	
CONCRETE CURBS AND COMBINED CURB & GUTTERS	DATE 10-28-94
STANDARD CONSTRUCTION DRAWING BP-5.1M	
APPROVED <u>W. K. Hehman</u>	ENGR., L & D