

CONDUIT SHALL NOT EXTEND MORE THAN 75 mm NOR LESS THAN 50 mm ABOVE CONCRETE

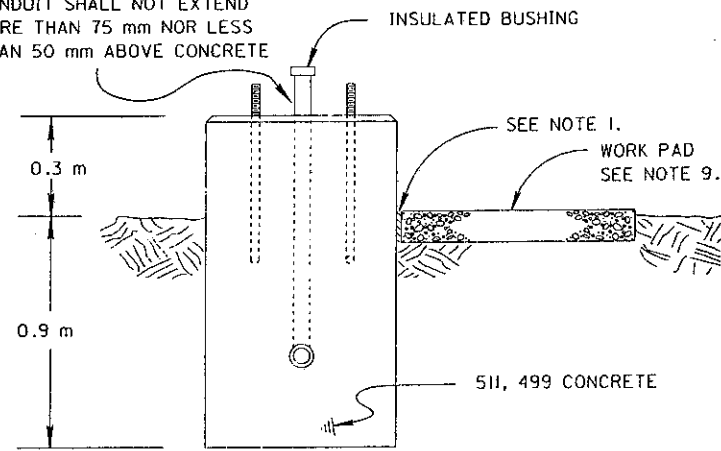

TYPE	W	D	FOUNDATION CONCRETE	WORK PAD
1	1.0 m	0.6 m	0.72 m <sup>3</sup>	0.80 m <sup>2</sup>
2	1.3 m	0.9 m	1.40 m <sup>3</sup>	1.04 m <sup>2</sup>

**GROUND MOUNTED  
CONTROLLER FOUNDATION**

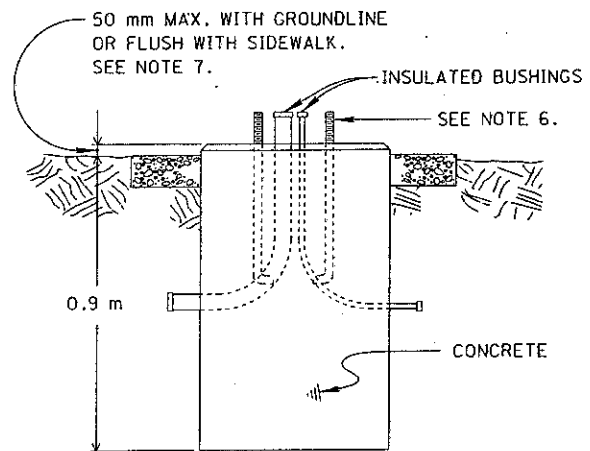
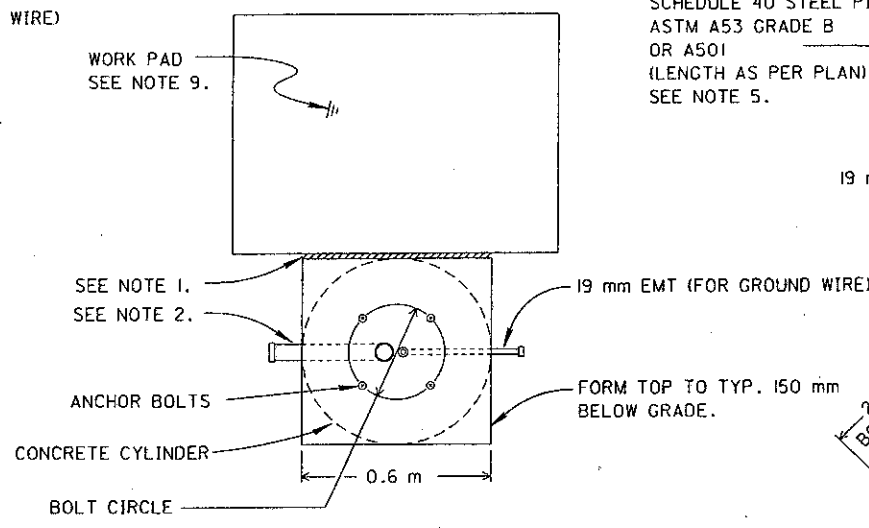

**PEDESTAL FOUNDATION**

FOUNDATION CONCRETE	WORK PAD
0.32 m <sup>3</sup>	0.80 m <sup>2</sup>

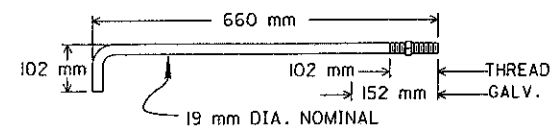

**PEDESTAL ANCHOR BOLT  
ASTM A307 STEEL**

114 mm O. D. PEDESTAL SHAFT  
SCHEDULE 40 STEEL PIPE  
ASTM A53 GRADE B  
OR A501  
(LENGTH AS PER PLAN)  
SEE NOTE 5.

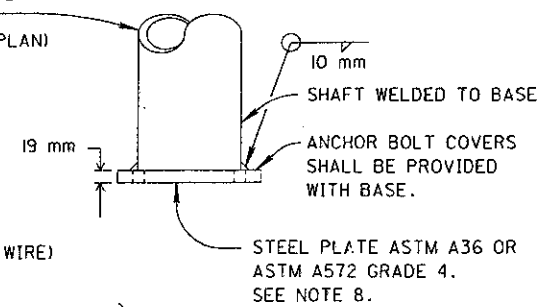

**PLATE PEDESTAL BASE**

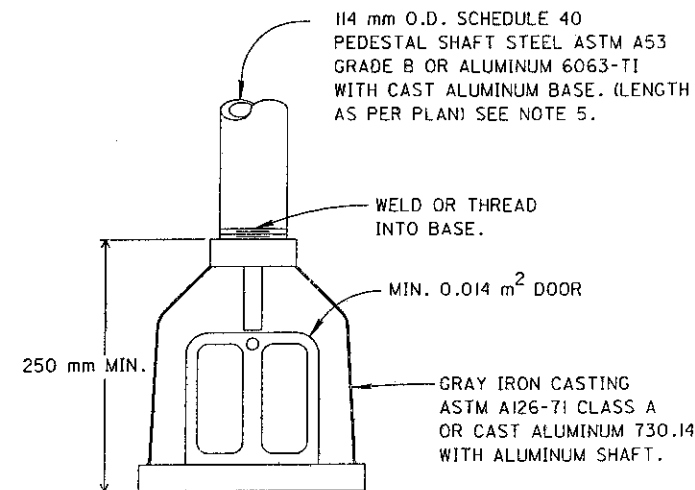
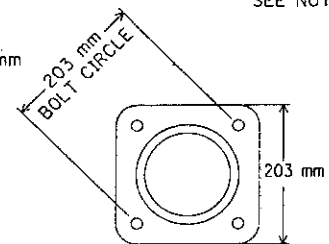

**TRANSFORMER TYPE  
PEDESTAL BASE**

**NOTES**

- 13 mm PREFORMED JOINT FILLER AS PER 705.03 SHALL BE USED BETWEEN FOUNDATIONS AND ADJACENT PAVED AREAS.
- THE SIZE, NUMBER AND ORIENTATION OF CONDUIT ELLS SHALL BE AS SHOWN IN THE PLANS, EXCEPT THAT ONE 19 mm EMT SHALL BE INSTALLED IN EACH FOUNDATION.
- THE SIZE, NUMBER AND LOCATION OF ANCHOR BOLTS SHALL BE IN ACCORDANCE WITH THE MANUFACTURER'S RECOMMENDATIONS.
- ALL PEDESTALS SHALL BE PROVIDED WITH A METHOD OF SECURELY ATTACHING A NO. 4 AWG INSULATED COPPER GROUNDING CABLE TO THE PEDESTAL OR ANCHOR BOLT. NO CABLES OR CONNECTIONS SHALL BE EXTERNAL TO THE PEDESTAL.
- THE PEDESTAL SHAFT LENGTH AS SHOWN IN THE PLANS INCLUDES THE PEDESTAL BASE HEIGHT FOR EITHER BASE DESIGN.
- THE PEDESTAL BASE SHALL SET ON THE FOUNDATION TOP WITHOUT GROUTING, PREFORMED FILLERS OR LEVELING NUTS UNDER THE BASE. STEEL SHIMS MAY BE USED UNDER THE BASE FOR LEVELING THE INSTALLATION.
- THE FOUNDATION AREA OF CONTACT WITH THE PEDESTAL BASE SHALL BE LEVEL. IF ADJACENT PAVED AREAS SLOPE, THE REMAINDER OF THE FOUNDATION TOP SHALL BE BEVELED TO MEET THE ADJACENT ELEVATIONS.
- A CAST STEEL ANCHOR BASE OF EQUIVALENT STRENGTH MAY BE USED IN LIEU OF THE PLATE BASE.
- A 1.0 m X 0.8 m X 100 mm WORK PAD SHALL BE LOCATED IN FRONT OF EACH PEDESTAL MOUNTED CONTROLLER CABINET UNLESS IN AN OTHERWISE PAVED AREA. THE WORK PAD FOR THE GROUND MOUNTED CONTROLLER SHALL BE SIZED AS SHOWN IN THE TABLE. WHEN REQUIRED, THIS ITEM SHALL BE PAID FOR UNDER ITEM 633 CONTROLLER WORK PAD. IN LEVEL AREAS THE TOP OF THE PAD SHALL BE 25 mm ABOVE THE GROUND LINE. IN STEEPLY SLOPED AREAS THE PAD'S LOCATION SHALL BE ADJUSTED TO PROVIDE ACCESS AND DRAINAGE.
- GROUND MOUNTED CONTROLLER CABINETS SHALL BE SEALED TO THE FOUNDATION WITH A FLEXIBLE WEATHERPROOF CAULKING COMPOUND.

**M E T R I C**

BUREAU OF DESIGN SERVICES  
DIVISION OF HIGHWAYS  
OHIO DEPARTMENT OF TRANSPORTATION

TRAFFIC CONTROL

DATE  
11-24-93

CONTROLLER FOUNDATION  
AND PEDESTALS

STANDARD  
CONSTRUCTION  
DRAWING  
TC-83.20M

APPROVED: *[Signature]* ENGR. OF DESIGN SERVICES