

ALL DIMENSIONS IN MILLIMETERS, UNLESS OTHERWISE NOTED.

TC-9.10 TYPE SUPPORTS						TC-16.20 & TC-81.20 TYPE SUPPORTS						TC-17.10 & 81.10 TYPE SUPPORTS						TC-12.30 TYPE SUPPORTS					
DESIGN NO.	D (meters)	W	ANCHOR BOLTS			DESIGN NO.	D (meters)	W	ANCHOR BOLTS			DESIGN NO.	D (meters)	W	ANCHOR BOLTS			DESIGN NO.	D (meters)	W	ANCHOR BOLTS		
			SIZE	CIRCLE	P				SIZE	CIRCLE	P				SIZE	CIRCLE	P				SIZE	CIRCLE	P
1	2.4	762	38 X 1.4 m	343	171	1	2.4	762	38 X 1.4 m	343	171	1	2.1	762	32 X 1.1 m	254	146	1	2.7	914	45 X 2.1 m	381	197
2	2.4	762	38 X 1.4 m	343	171	2	2.4	762	38 X 1.4 m	381	171	2	2.1	762	38 X 1.4 m	318	171	2	2.7	914	45 X 2.1 m	381	197
3	2.7	914	45 X 2.1 m	406	197	3	2.7	762	38 X 1.4 m	406	171	3	2.4	762	38 X 1.4 m	343	171	3	3.4	914	51 X 2.3 m	457	216
						4	3.1	914	45 X 2.1 m	457	197	4	2.4	914	45 X 2.1 m	381	197	4	3.4	914	51 X 2.3 m	457	216
						5	2.7	914	45 X 2.1 m	381	197	5	2.7	914	45 X 2.1 m	406	197	5	3.4	914	51 X 2.3 m	559	216
						6	2.7	914	45 X 2.1 m	381	197	6	2.7	914	45 X 2.1 m	406	197	6	3.4	914	51 X 2.3 m	559	216
						7	2.7	914	45 X 2.1 m	381	197	7	3.1	914	51 X 2.3 m	457	216	7	4.6	914	64 X 2.9 m	597	248
						8	2.7	914	45 X 2.1 m	406	197	8	3.1	914	51 X 2.3 m	508	216	8	4.6	914	64 X 2.9 m	597	248
						9	3.1	914	45 X 2.1 m	457	197	9	3.1	914	51 X 2.3 m	559	216	9	4.6	914	64 X 2.9 m	597	248
						10	3.1	914	45 X 2.1 m	508	197	10	3.4	914	57 X 2.3 m	559	229	10	5.2	914	64 X 2.9 m	648	248
						11	3.1	914	45 X 2.1 m	508	197	11	3.4	914	57 X 2.3 m	559	229	11	5.2	914	64 X 2.9 m	648	248
						12	3.4	914	51 X 2.3 m	508	216	12	3.7	914	64 X 2.9 m	597	248	12	5.5	914	76 X 3.5 m	648	286

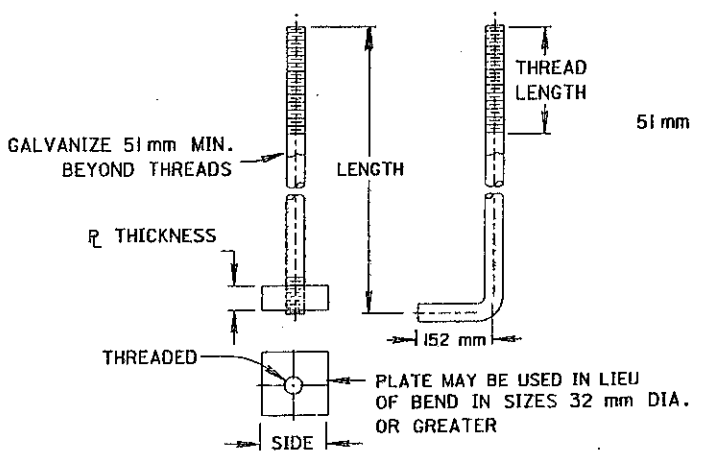
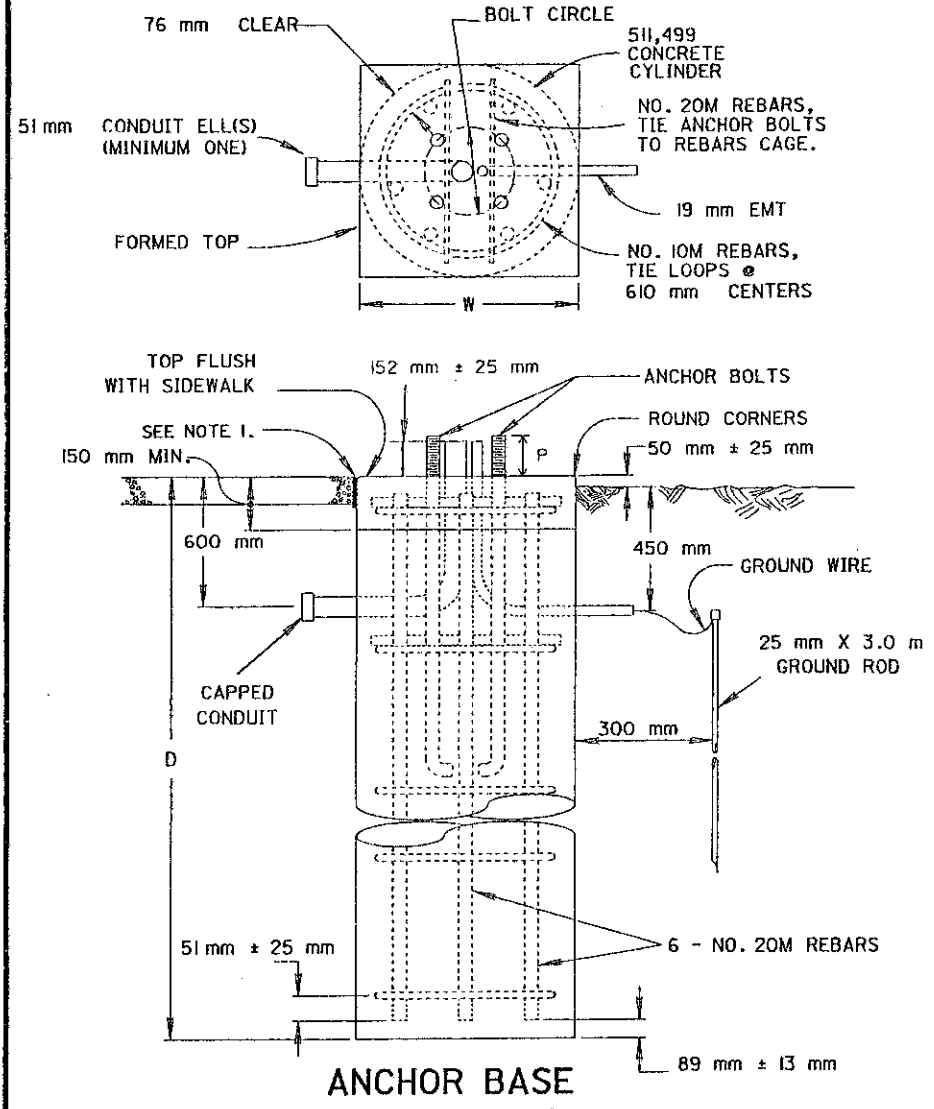

ALL DIMENSIONS IN MILLIMETERS, UNLESS OTHERWISE NOTED

DIA.	LENGTH (meters)	THREAD LENGTH	R THICK	R SIDE	THREAD
32	1.1	203	38	102	32 - 3.6
38	1.4	229	38	102	38 - 4.2
45	2.1	229	51	127	45 - 5.1
51	2.3	229	51	127	51 - 5.6
57	2.3	254	64	152	57 - 5.6
64	2.9	254	64	152	64 - 6.4
76	3.5	305	76	178	76 - 6.4

ANCHOR BOLTS

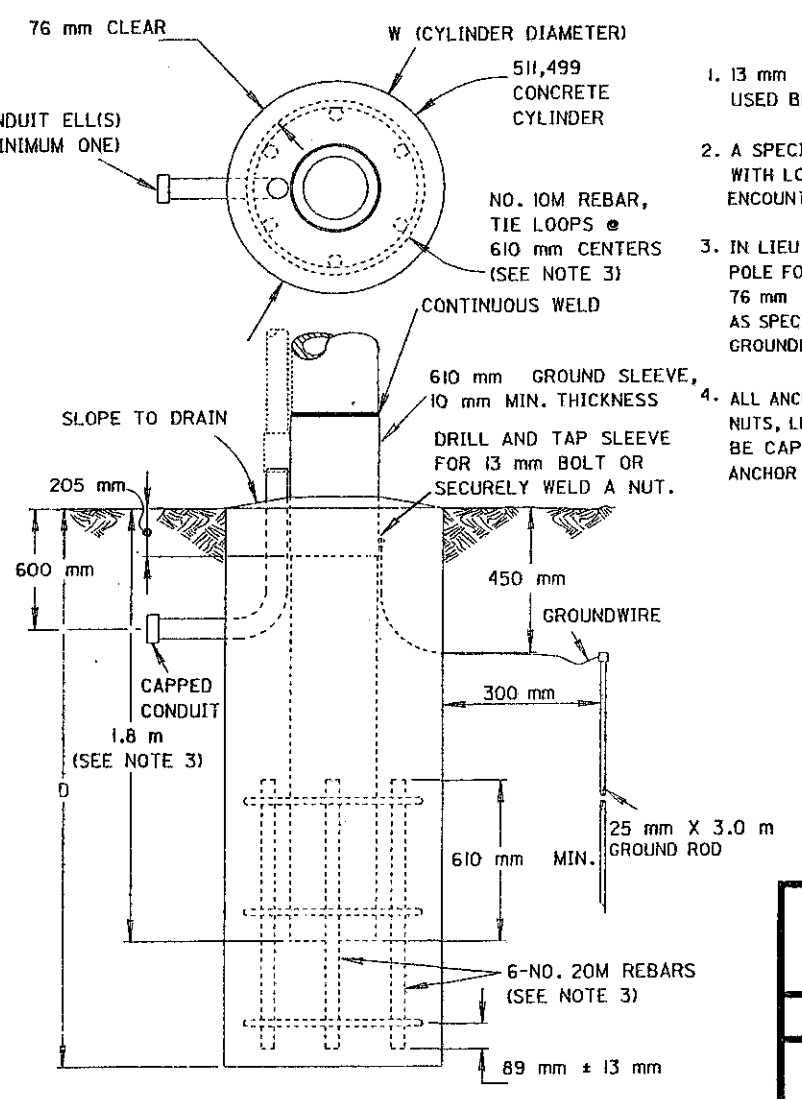

NOTES

- 13 mm PREFORMED JOINT FILLER AS PER 705.03 SHALL BE USED BETWEEN FOUNDATIONS AND ADJACENT PAVED AREAS.
- A SPECIAL FOUNDATION DESIGN WILL BE REQUIRED WHEN SOIL WITH LOAD BEARING CAPACITY OF LESS THAN 9700 kg/m² IS ENCOUNTERED.
- IN LIEU OF PROVIDING REINFORCING STEEL IN THE EMBEDDED POLE FOUNDATION, THE POLE BUTT MAY BE EXTENDED TO WITHIN 76 mm OF THE FOUNDATION BOTTOM. THE POLE BASE DIAMETER AS SPECIFIED IN THE PLANS IS THE DIAMETER OF THE POLE AT THE GROUNDLINE.
- ALL ANCHOR BOLTS SHALL BE PROVIDED WITH STANDARD STEEL HEX NUTS, LEVELING NUTS, PLAIN AND LOCKWASHERS. THE NUTS SHALL BE CAPABLE OF DEVELOPING THE FULL STRENGTH OF THE ANCHOR BOLTS.



metric units

OFFICE OF TRAFFIC ENGINEERING
DIVISION OF ENGINEERING POLICY
OHIO DEPARTMENT OF TRANSPORTATION

TRAFFIC CONTROL

DATE 02/01/94
12/10/96

FOUNDATIONS

STANDARD CONSTRUCTION DRAWING TC-21.20M

APPROVED *[Signature]* ADMINISTRATOR