

TYPE A

TYPE B

TYPE C

TYPE D

NORMAL SECTIONS

LEGEND

- 1 25-mm radius or 19-mm chamfer.
- 2 Permissible 250-mm radius.
- 3 Permissible 25-mm radius.
- 4 #25M epoxy coated deformed steel bars, 305 mm long, spaced 1220 mm between successive bars on a staggered pattern except in Type D. Omit dowels when the top is constructed integrally with the base.

W = 152 or 305 mm barrier width, as specified in the plans.

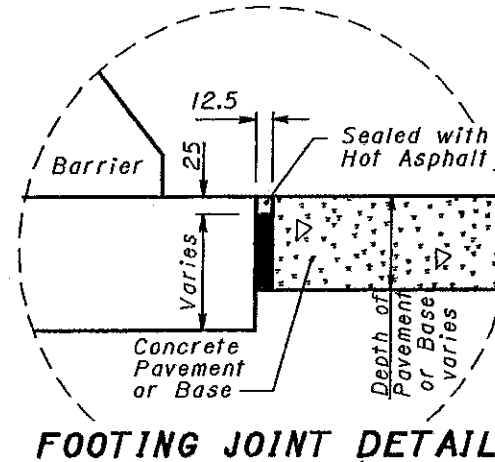

FOOTING JOINT DETAIL

NOTES

JOINTS: Unsealed contraction joints spaced at 6 m maximum shall be constructed throughout the run of Concrete Barrier except that expansion joints shall be used at the center line of and around each bridge pier column and on either side of overhead sign supports, inlets and light pole foundations. If the inlet top is slip formed, the expansion joints adjacent to it may be omitted.

Contraction joints may be constructed with metal inserts inside the forms, preformed full width joint filler, a grooving tool, or by sawing. Inserts, tooled or sawed joints shall have a 75-mm minimum depth. All joints shall be constructed for the full height of the barrier including the footing. Sawing shall be done as soon as curing will allow, to prevent spalling.

FOOTING JOINTS: The vertical walls between the barrier footing and a concrete pavement or concrete base shall be provided with a sealed joint as shown. Sealing material shall conform to CMS 705.04.

P.C.J. - Permissible Construction Joint

MEASUREMENT: Item 622, Concrete Barrier, including transitions and pier sections detailed on SCD RM-4.4M, is paid for in meters as one of the four types (A, B, C or D) or as Type A1 and B1, (for 1270 mm high barrier), with appropriate deductions for other items such as:

- Item 604 1-3 Median inlet 6 meters.
- Item 625 Light pole foundation or pullbox 1 meter.
- Item 630 Overhead sign support foundation 3 meters.
- Item 630 Barrier wall assembly 3 meters.

1270-mm BARRIER: High barrier shall be built in locations specified in the plans. Construct the lower 813 mm of the barrier base using the same dimensions as shown in the corresponding Normal Section. The upper 457 mm may be constructed integral with the bottom, or separately with #15M rebar dowels at 1220 mm maximum spacing. Start and end dowels 150 mm from barrier contraction joints.

RACEWAY: The contractor shall ensure that the electrical raceway is clear of internal obstructions. Cost of the 100 mm polyvinyl chloride raceway and No. 10 AWG copper-clad or aluminum-clad wire if needed for future installation of circuits shall be included in the unit cost per meter for Item 622, Concrete Barrier.

STATION MARKING: Marking shall be impressed in the "green" concrete on both sides at the top of the barrier if specified in the plans, which cost shall be incidental to the unit cost per meter bid for Item 622, Concrete Barrier.

All dimensions are in millimeters unless otherwise noted.

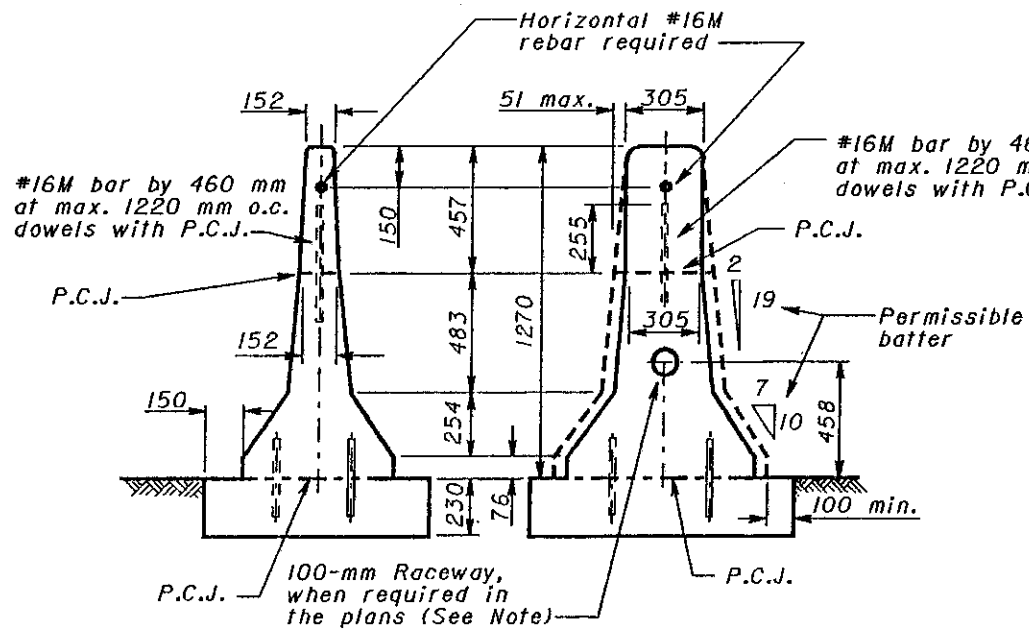

TYPE A1

TYPE B1

1270-mm BARRIERS - TYPICAL SECTIONS

See Type A and Type B Normal Section Details for dimensions that are not shown.

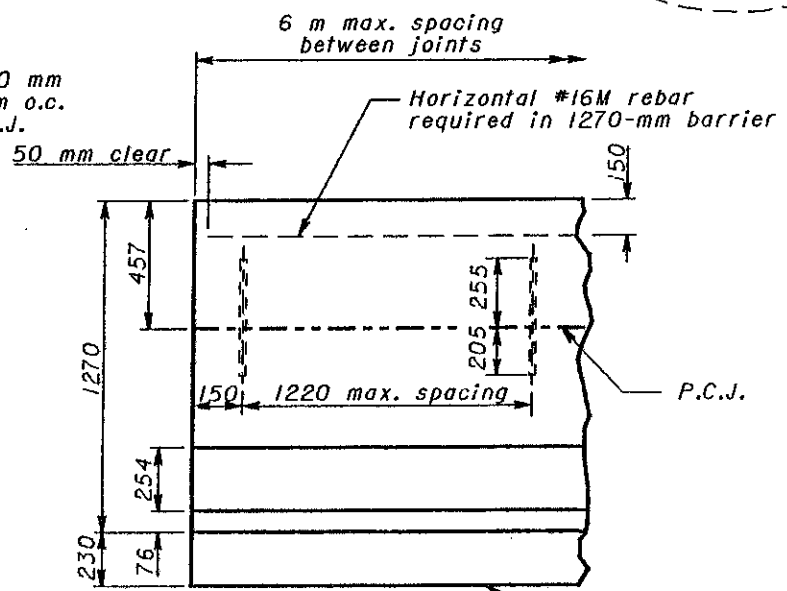

1270-mm BARRIER

BARRIER ELEVATIONS

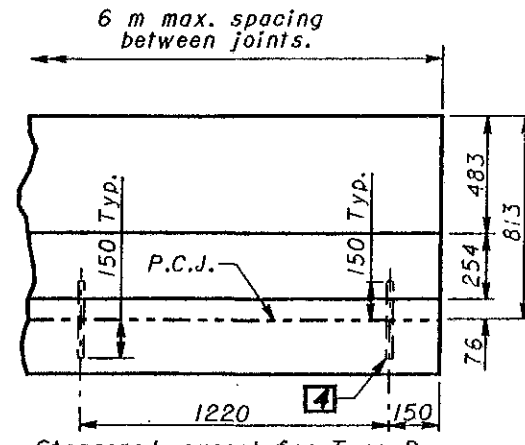

813-mm BARRIER



This Drawing Replaces MC-9.3.

OHIO DEPARTMENT OF TRANSPORTATION

CONCRETE BARRIERS

STANDARD CONSTRUCTION DRAWING **RM-4.3M**

APPROVED *[Signature]*

DATE
6-30-95
10-21-97