

# CATCH BASIN No. 2-2A

# NOTES

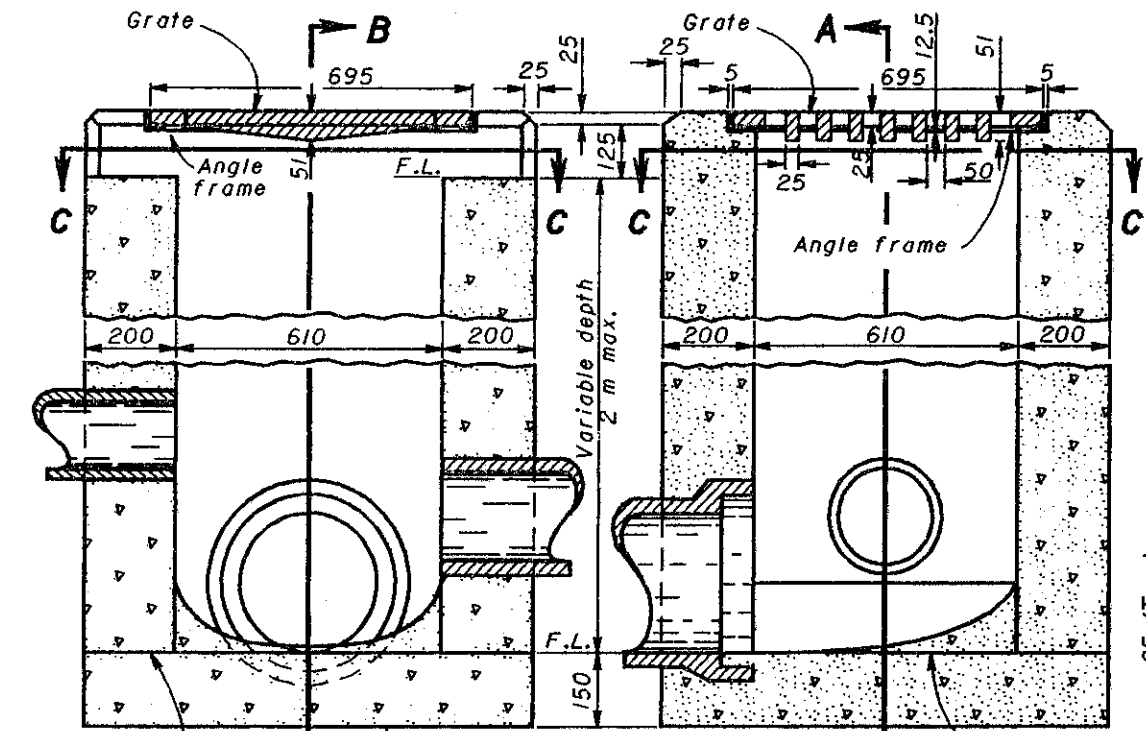

Permissible const. joint

Bottom slab may be precast separately and the outlet pipe placed on top of it with the bottom shaped to drain

Permissible const. joint

SECTION A-A

SECTION B-B

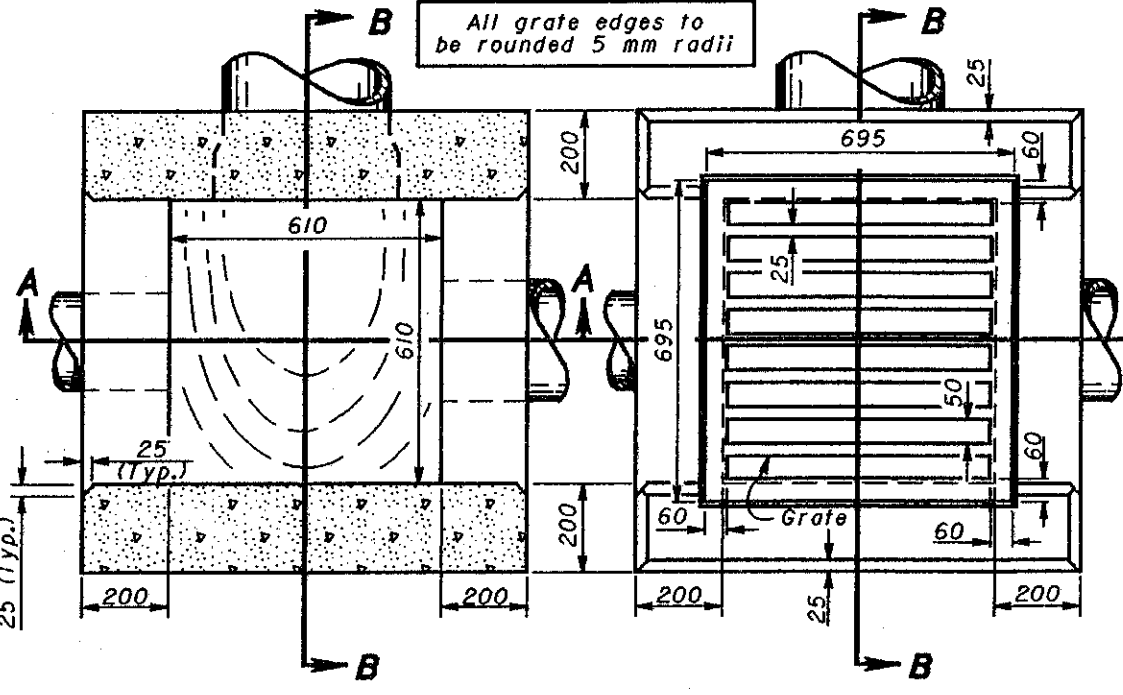

SECTION C-C

PLAN

# CATCH BASIN No. 2-2B

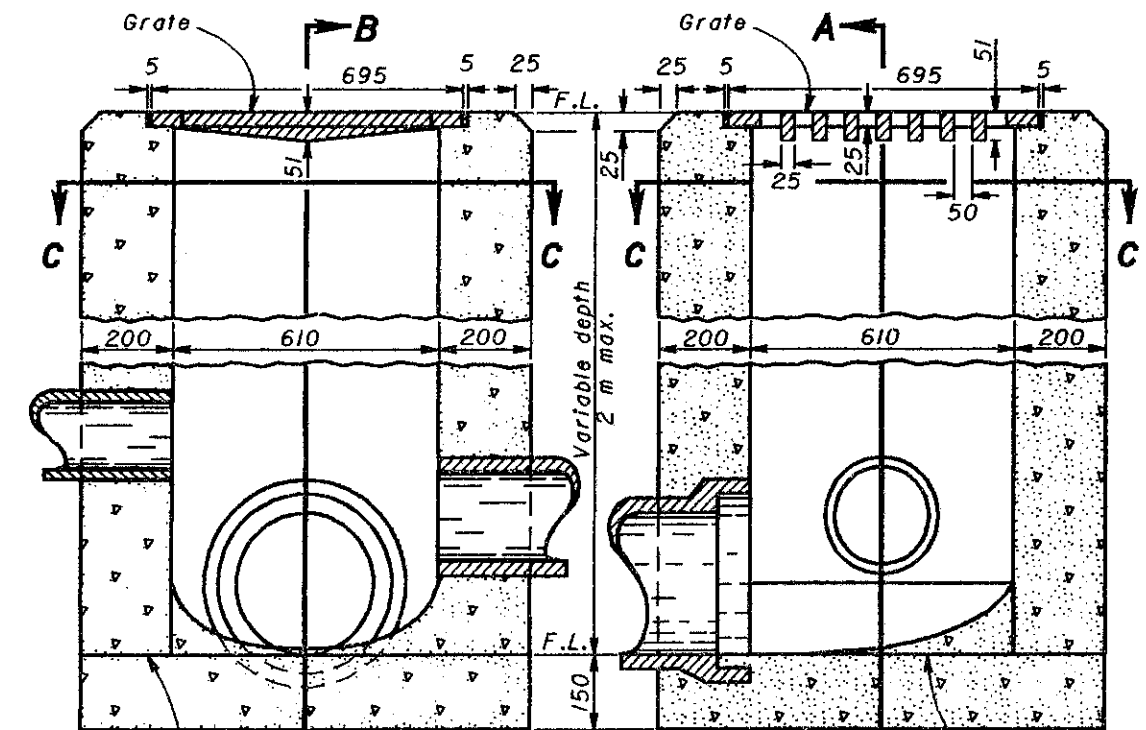

Permissible const. joint

Bottom slab may be precast separately and the outlet pipe placed on top of it with the bottom shaped to drain

Permissible const. joint

SECTION A-A

SECTION B-B

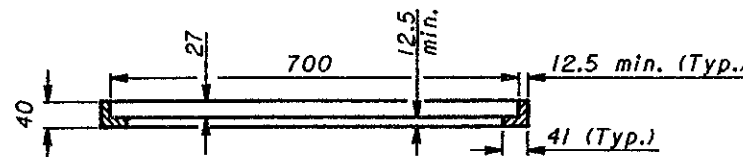

SECTION THRU ANGLE FRAME FOR STANDARD No. 2-2A CATCH BASIN

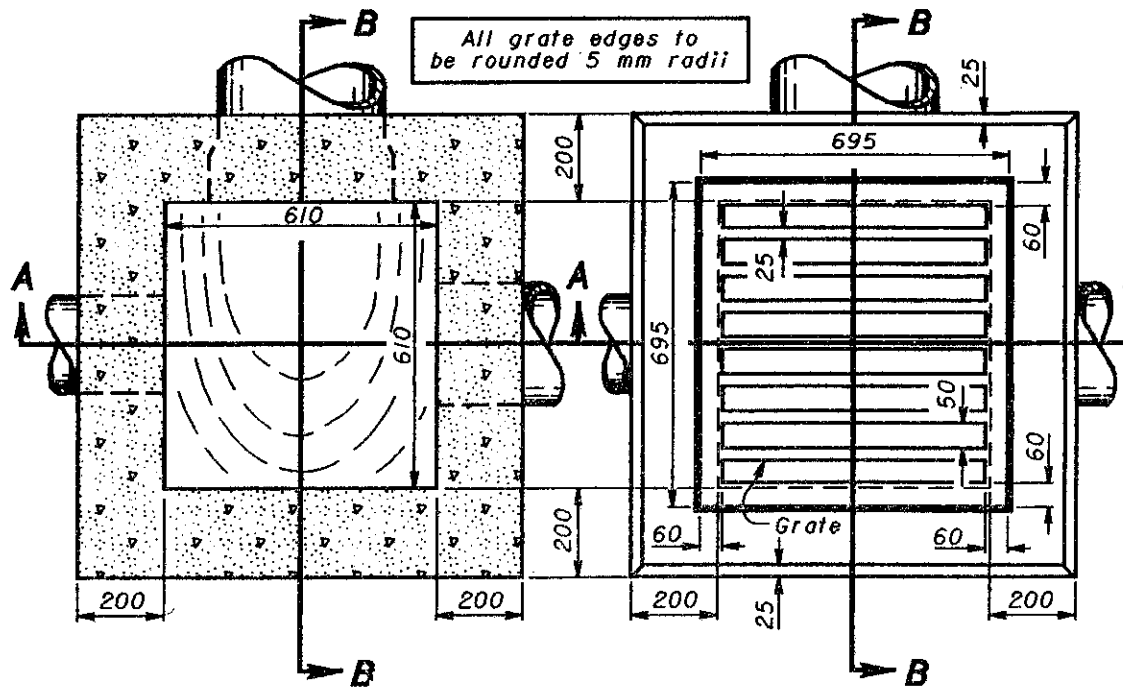

SECTION C-C

PLAN

**GRATE AND FRAME:** The design shall be essentially the same and equally as strong as the one shown hereon.

**WALLS:** Brick or cast-in-place walls have a nominal thickness of 200 mm. Precast walls shall have a minimum thickness of 150 mm and be reinforced sufficiently to permit shipping and handling without damage. Brick shall not be used above the flow line of the side opening for Type 2-2A.

**CONCRETE:** Cast-in-place concrete is to be Class C. All precast concrete shall meet the requirements of CMS 706.13 with a minimum of 4% entrained air in the hardened concrete and be marked with the catch basin number.

**PRECAST BASE:** If a precast base is used, it shall be set deep enough so that the top can be placed on the base to provide the grate elevation specified in the plans. Layers of brick shall not be used to adjust the top elevation.

**LOCATION AND ELEVATION:** When given on the plans, location and elevation are at the top center of the grate. When side openings are provided, the elevation shall be at the flow line of the side inlet.

**MINIMUM DEPTH:** The minimum depth of CB No. 2-2A shall be the outside diameter (O.D.) of the outlet pipe plus 180 mm. The minimum depth for CB No. 2-2B shall be the O.D. of the outlet pipe plus 105 mm.

**2-2B GRATE ELEVATION:** Grate elevation is to be placed 100 to 150 mm below normal ditch, returning to normal 3 to 5 m each side of inlet.

**OPENINGS:** Pipe openings shall be the O.D. of the pipe being supplied plus 50 mm when fabricated or field cut. The interstitial space shall be filled with grout per CMS 601.

**2-2A SIDE INLETS:** Inlets shall be provided on both sides of the No. 2-2A catch basin in sags and on upstream side only where the ditch has a continuous down grade past the catch basin. Side inlets shall not be used within the Clear Zone. The flow line should be 100 to 150 mm below the normal elevation of the ditch flow line, returning to normal within 3 to 5 m of the basin.

CONSTRUCTION INFORMATION	
Minimum mass of grate,	54 kg
Minimum mass of frame,	18 kg

All dimensions are in millimeters unless otherwise noted.



This Drawing Replaces CB-2-2 A & B.

BUREAU OF LOCATION AND DESIGN  
OHIO DEPARTMENT OF TRANSPORTATION

CATCH BASINS  
No's 2-2A & B

DATE  
7-12-95

STANDARD  
CONSTRUCTION  
DRAWING  
CB-1.1M

APPROVED *W. K. Hulman*  
ENGR., L & D