

TIE BAR OR HOOK BOLT SPACING

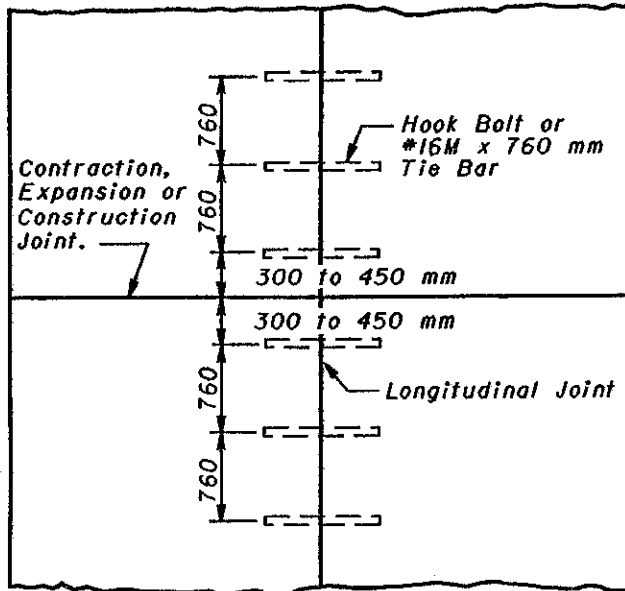

PLAN

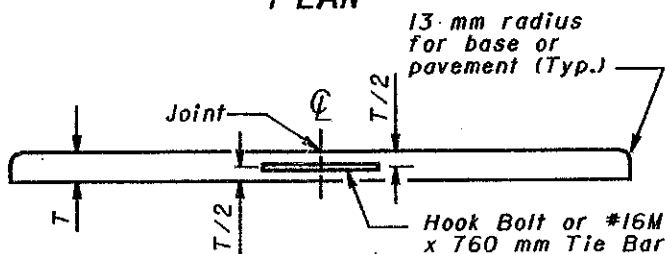

CROSS SECTION

GROOVE AND SEAL DETAIL

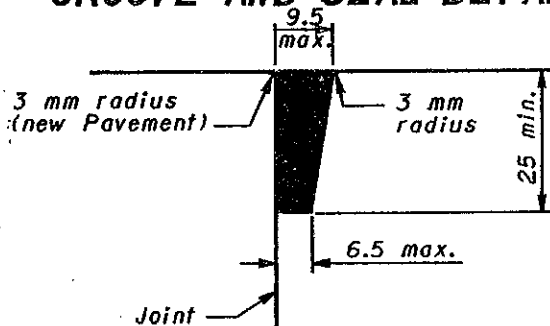

BUTT JOINT

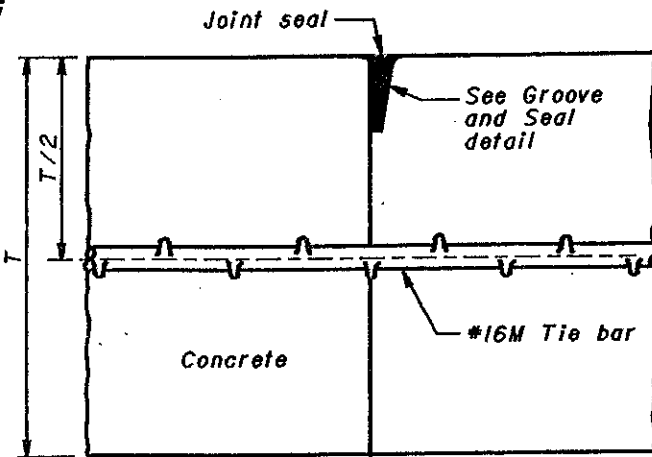

DETAIL OF JOINT

SAWED JOINT

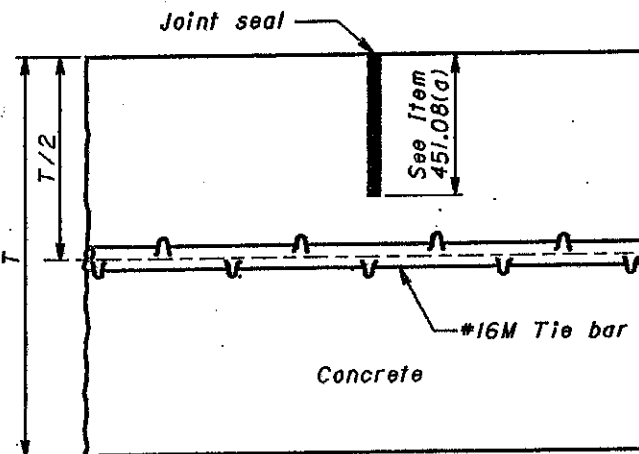

DETAIL OF JOINT

HOOK BOLT

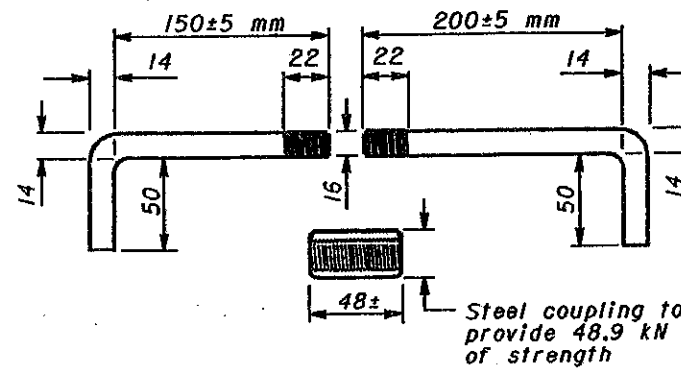

HOOK BOLT ALTERNATE

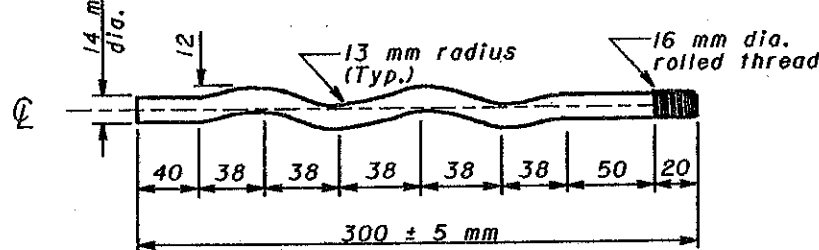

NYLON OR PLASTIC GROUT RETENTION DISCS FOR DOWEL/TIE BARS
(1.6 mm min. thickness)

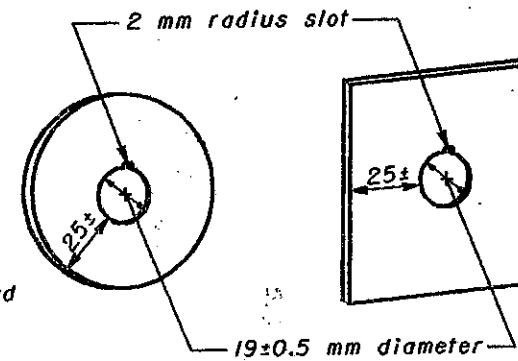

NOTES

GENERAL: Longitudinal joints shall be used when specified on the typical section and shall be constructed as shown on this drawing in Items 451 and 452 Pavement and Item 305 Base.

The joint shall be on the centerline of the pavement unless otherwise shown on the plans. Where the pavement width exceeds 5.0 m, an additional longitudinal joint shall be introduced into the jointing details as directed by the Engineer.

Tie bars shall be #16M deformed bars. A satisfactory device shall be used to hold the tie bars in proper position or they may be installed by a mechanical installing device.

BUTT JOINT: The longitudinal joint between adjoining slabs poured in separate operations shall be a butt joint with hook bolts or tie bars, unless otherwise shown on the plans. Bent tie bars shall not be permitted.

TYPE D (DRILLED TIED LONGITUDINAL) JOINT: Type D joints shall be constructed in accordance with Item 255.05. The nylon or plastic retention disc shall be clear or opaque white in color. Grout shall meet the requirements of Item 255.02. 16 mm expansion anchors, FF-S-325, Group VIII, Type I or Group II Type 4, Class I may be used lieu of the #16M x 600 mm deformed bar and shall be installed according to the manufacturer's recommendations.

The use of self drilling expansion shield anchors, FF-S-325, Group III, Type I (a) and (c) shall not be permitted.

GROOVES: Grooves for sealing expansion bolt or butt joints in Item 451 or 452 pavements shall be formed by depressing a device or bar into the newly deposited concrete adjacent to the existing or previously poured lane. The device or bar shall be removed as soon as the concrete is in such condition as to preclude distortion of the concrete.

Adjoining slabs adjacent to grooved joints shall be edged with a thin metal edger having a radius of 3 mm. Any impression left in the surface of the pavement by the flat part of the edging tool shall be eliminated.

In lieu of the above method the longitudinal joint may be constructed in accordance with Item 451.08(a).

After the joint is formed it shall be protected from dirt and foreign matter until the joint seal is placed.

SEALING JOINTS: Sawed or hand-formed joints may be sealed with Item 705.04 or 705.11 joint sealer.

HOOK BOLTS: Hook bolt inserts shall be turned to a tight fit when installed in threaded hook bolts or couplings.

METAL STRENGTH: Tie bars, hook bolt assemblies and the hook bolt alternate shall have a minimum strength of 48.9 kN.

All dimensions are in millimeters unless otherwise noted.

TYPE D (DRILLED TIED LONGITUDINAL) JOINT

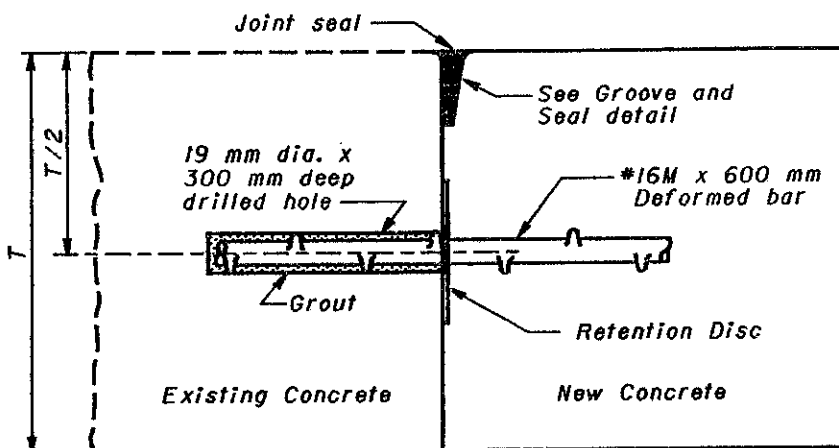

BUTT JOINT

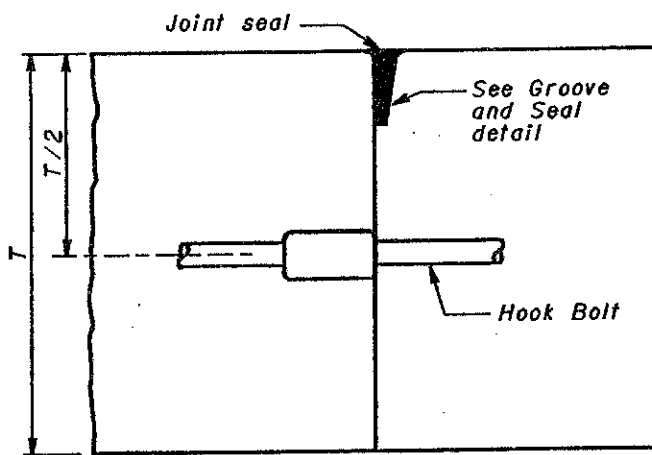

ACCEPTABLE METHOD OF FORMING JOINT

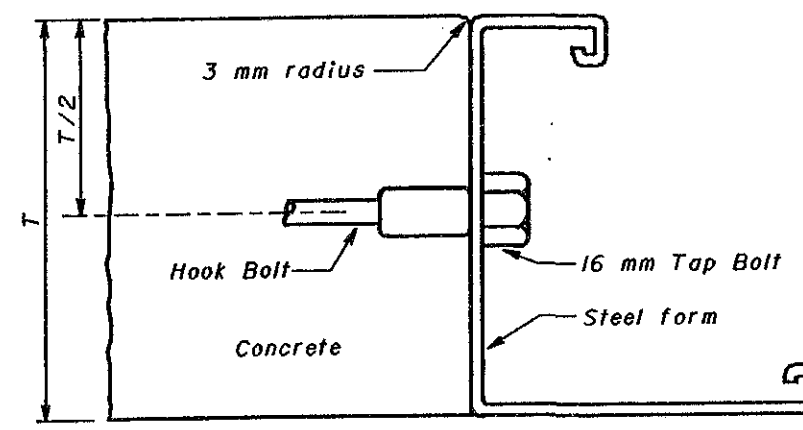

This Drawing Replaces BP-2.1.

OFFICE OF PLANNING
OHIO DEPARTMENT OF TRANSPORTATION

LONGITUDINAL PAVEMENT JOINTS

DATE
10-28-94
4-8-97

STANDARD CONSTRUCTION DRAWING **BP-2.1M**

APPROVED *Larry F. Luskland*
ADMINISTRATOR