

# DETAILS

LAKE COUNTY  
LAK-283-0.000  
metric  
units

79  
121

PLAN NO.

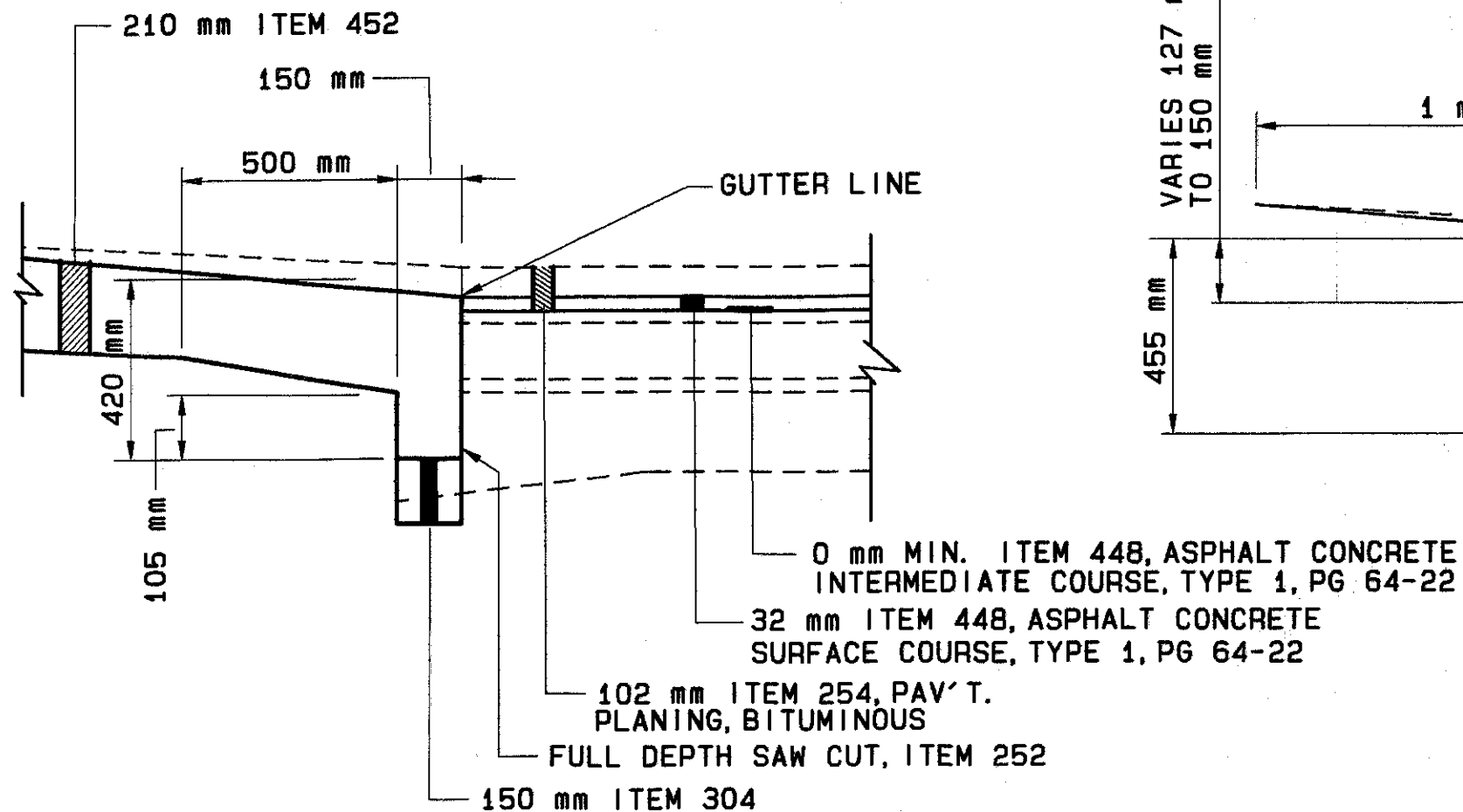

## DRIVE APRON DETAIL

- ☉ STA. 0+882, RIGHT
- ☉ STA. 1+246, RIGHT
- ☉ STA. 1+440, RIGHT
- ☉ STA. 1+627, RIGHT
- ☉ STA. 2+003, RIGHT
- ☉ STA. 2+139, RIGHT
- ☉ STA. 2+221, RIGHT

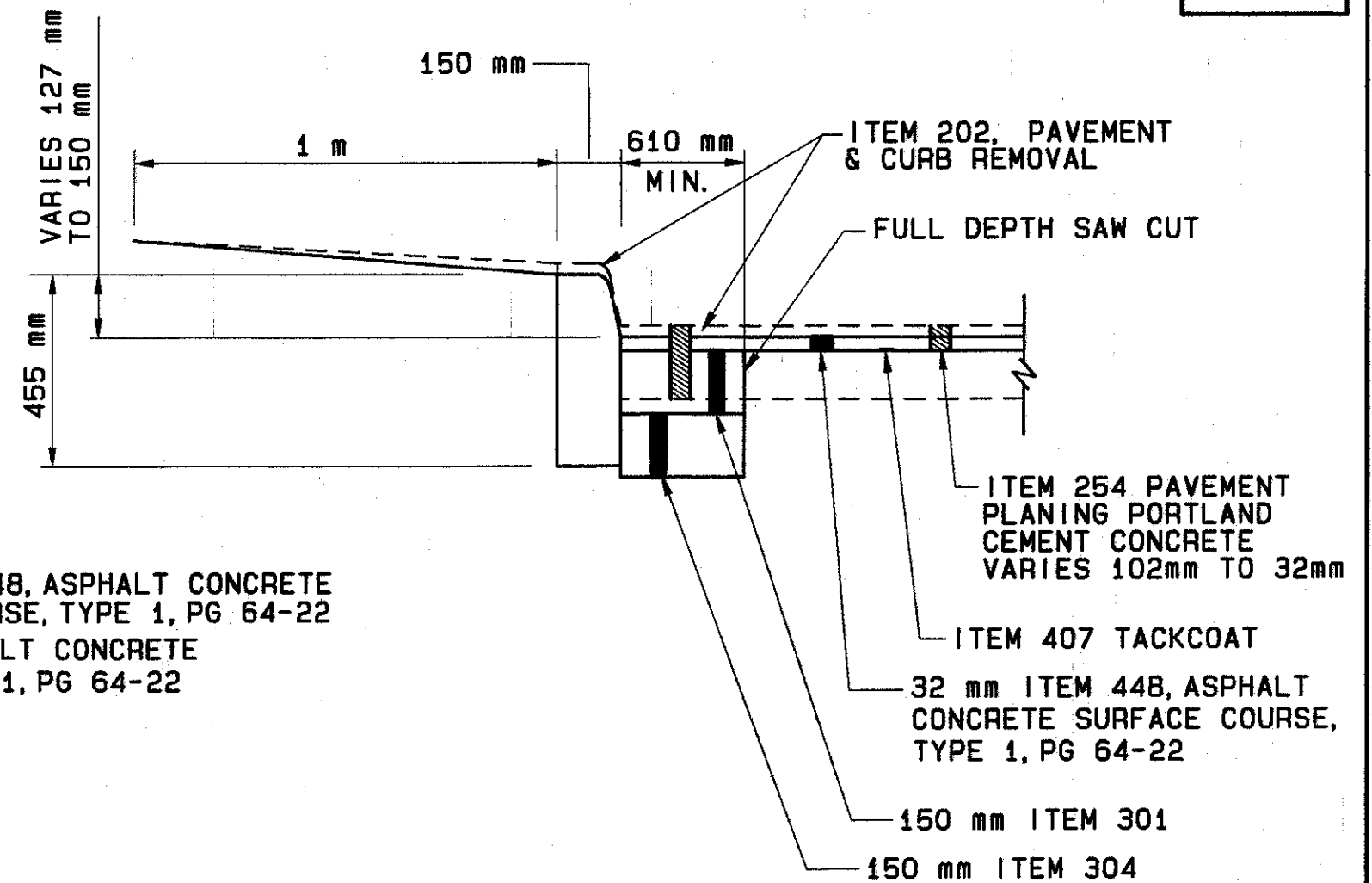

## PAVEMENT REPLACEMENT DETAIL - SIDE STREETS

- EAST 286TH STREET
- EAST 288TH STREET
- EAST 294TH STREET

93300 FRI 08/08/97 01:22 PM MATT FILES: D110.PLT

DETAILS - LAYER 110