

SIGNALS

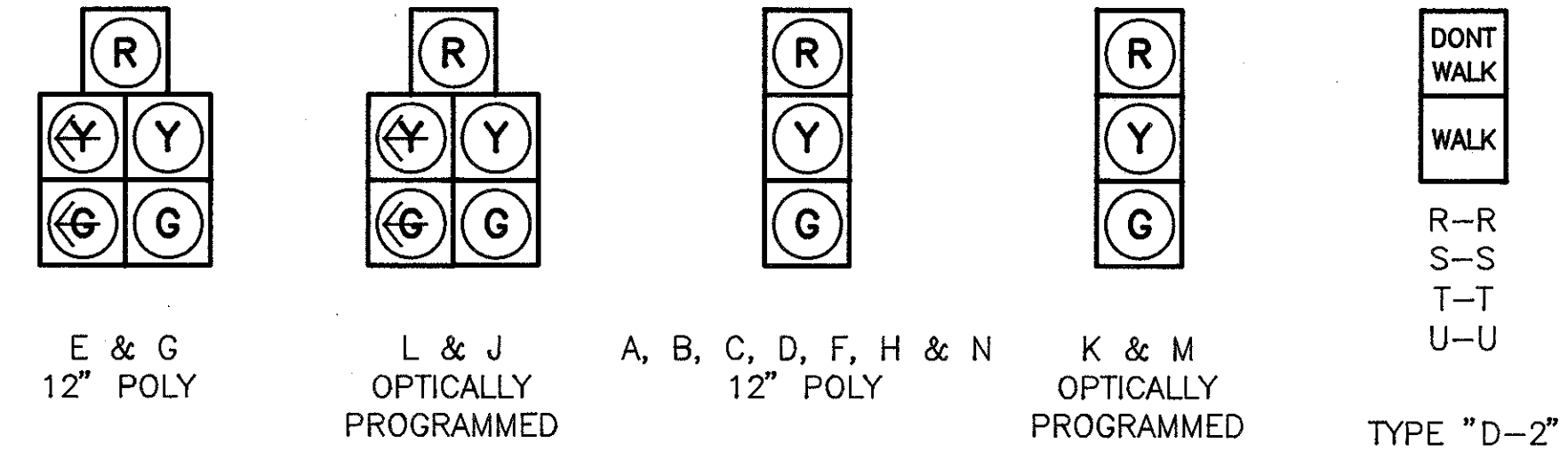

SIGNALS C, D, E & F SHALL HAVE TUNNEL VISORS
ALL PAVEMENT MARKINGS BY OTHERS

THE UNDERGROUND UTILITIES ARE SHOWN ACCORDING TO INFORMATION FURNISHED BY THE UTILITIES CONCERNED AND THE STATE DOES NOT GUARANTEE THE ACCURACY THEREOF.

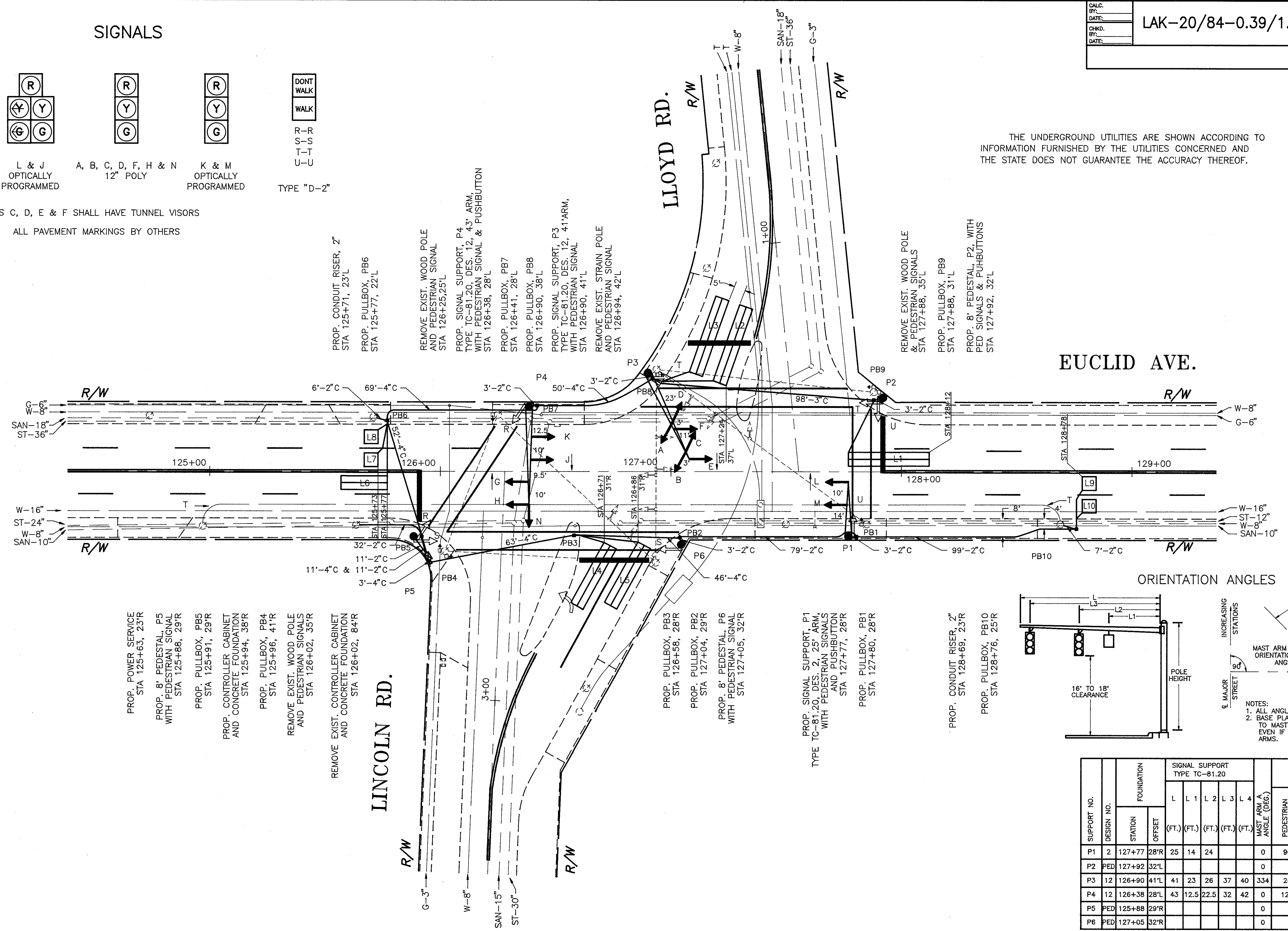
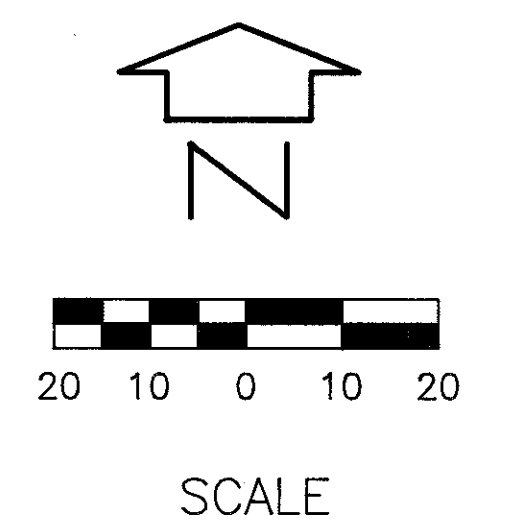

PROP. POWER SERVICE STA 125+63, 23'R
PROP. 8' PEDESTAL, P5 WITH PEDESTRIAN SIGNAL STA 125+88, 29'R
PROP. PULLBOX, PB5 STA 125+91, 29'R
PROP. CONTROLLER CABINET AND CONCRETE FOUNDATION STA 125+94, 38'R
PROP. PULLBOX, PB4 STA 125+96, 41'R
REMOVE EXIST. WOOD POLE AND PEDESTRIAN SIGNALS STA 126+02, 35'R
REMOVE EXIST. CONTROLLER CABINET AND CONCRETE FOUNDATION STA 126+02, 84'R

PROP. CONDUIT RISER, 2" STA 125+71, 23'L
PROP. PULLBOX, PB6 STA 125+77, 22'L
REMOVE EXIST. WOOD POLE AND PEDESTRIAN SIGNAL STA 126+25, 25'L
PROP. SIGNAL SUPPORT, P4 TYPE TC-81.20, DES. 12, 43' ARM, WITH PEDESTRIAN SIGNAL & PUSHBUTTON STA 126+38, 28'L
PROP. PULLBOX, PB7 STA 126+41, 28'L
PROP. PULLBOX, PB8 STA 126+90, 38'L
PROP. SIGNAL SUPPORT, P3 TYPE TC-81.20, DES. 12, 41' ARM, WITH PEDESTRIAN SIGNAL STA 126+90, 41'L
REMOVE EXIST. STRAIN POLE AND PEDESTRIAN SIGNAL STA 126+94, 42'L

PROP. PULLBOX, PB3 STA 126+58, 28'R
PROP. PULLBOX, PB2 STA 127+04, 29'R
PROP. 8' PEDESTAL, P6 WITH PEDESTRIAN SIGNAL STA 127+05, 32'R
PROP. SIGNAL SUPPORT, P1 TYPE TC-81.20, DES. 2, 25' ARM, WITH PEDESTRIAN SIGNALS AND PUSHBUTTON STA 127+77, 28'R
PROP. PULLBOX, PB1 STA 127+80, 28'R
PROP. CONDUIT RISER, 2" STA 128+69, 23'R
PROP. PULLBOX, PB10 STA 128+76, 25'R

ORIENTATION ANGLES

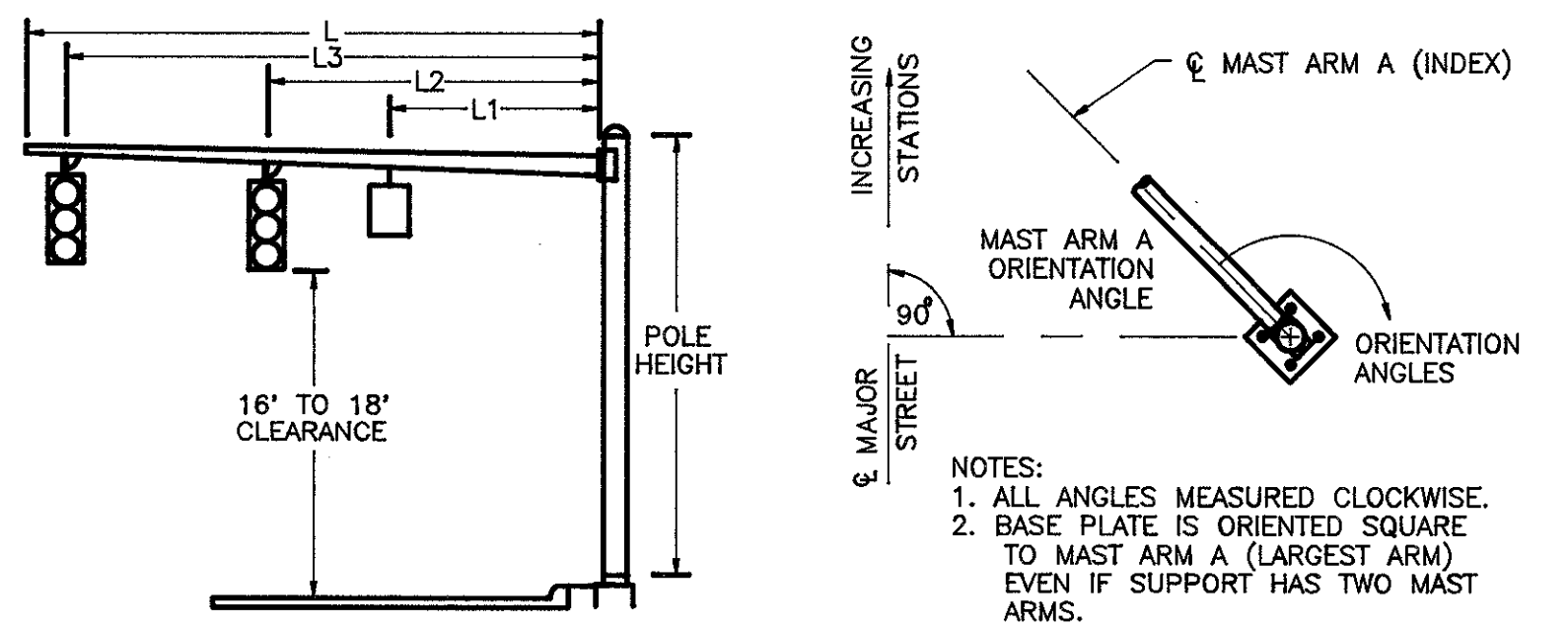

SUPPORT NO.	DESIGN NO.	FOUNDATION		SIGNAL SUPPORT TYPE TC-81.20					ORIENTATION ANG. (DEG.) FROM MAST ARM A			
		STATION	OFFSET	L (FT.)	L 1 (FT.)	L 2 (FT.)	L 3 (FT.)	L 4 (FT.)	MAST ARM A ANGLE (DEG.)	PEDESTRIAN SIGNALS	PEDESTRIAN PUSHBUTTON	HANDHOLE
P1	2	127+77	28'R	25	14	24			0	90	0	180
P2	PED	127+92	32'L						0		270	180
P3	12	126+90	41'L	41	23	26	37	40	334	26		180
P4	12	126+38	28'L	43	12.5	22.5	32	42	0	125	0	180
P5	PED	125+88	29'R						0		90	180
P6	PED	127+05	32'R						0			180