

LAKE COUNTY  
LAK-2-5.30

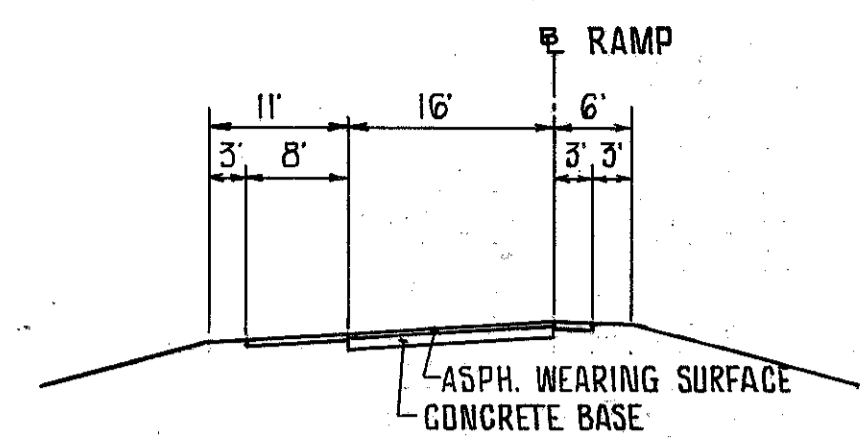

EXISTING RAMP TYPICAL

LEGEND

- ITEM 615 - TEMPORARY PAVEMENT, CLASS "A", AS PER PLAN.
- EXISTING CONCRETE MEDIAN TO BE REMOVED
- SHOULDER REPLACEMENT

FOR EXISTING PAVEMENT DETAILS SEE SHEETS 18 & 19 WHICH ARE FROM THE ORIGINAL LAK-2-4.42 HIGHWAY PLANS CONSTRUCTED IN 1959.

FOR GEOMETRICS ON TEMPORARY RAMP "M" SEE SHEET 19.

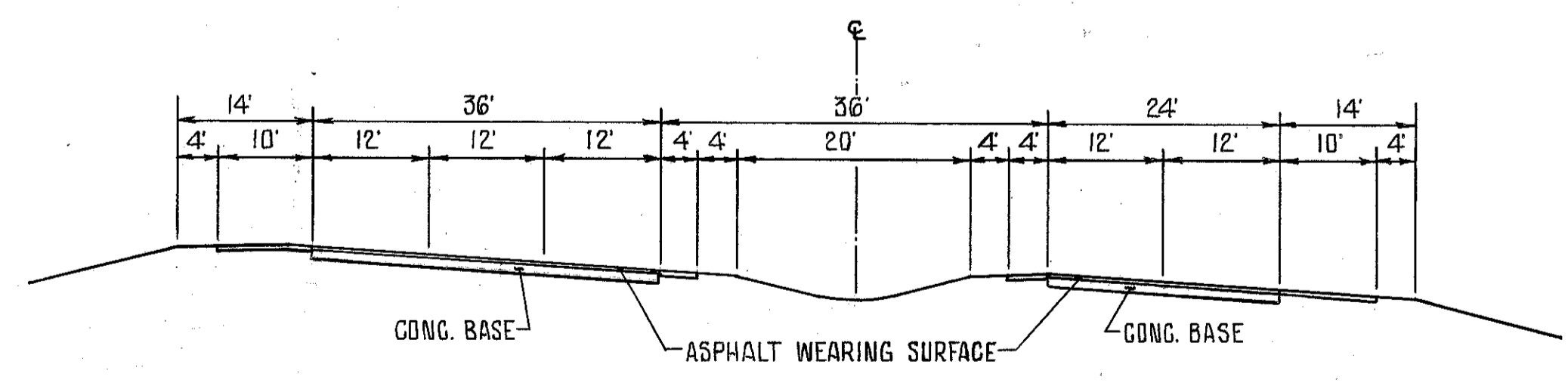
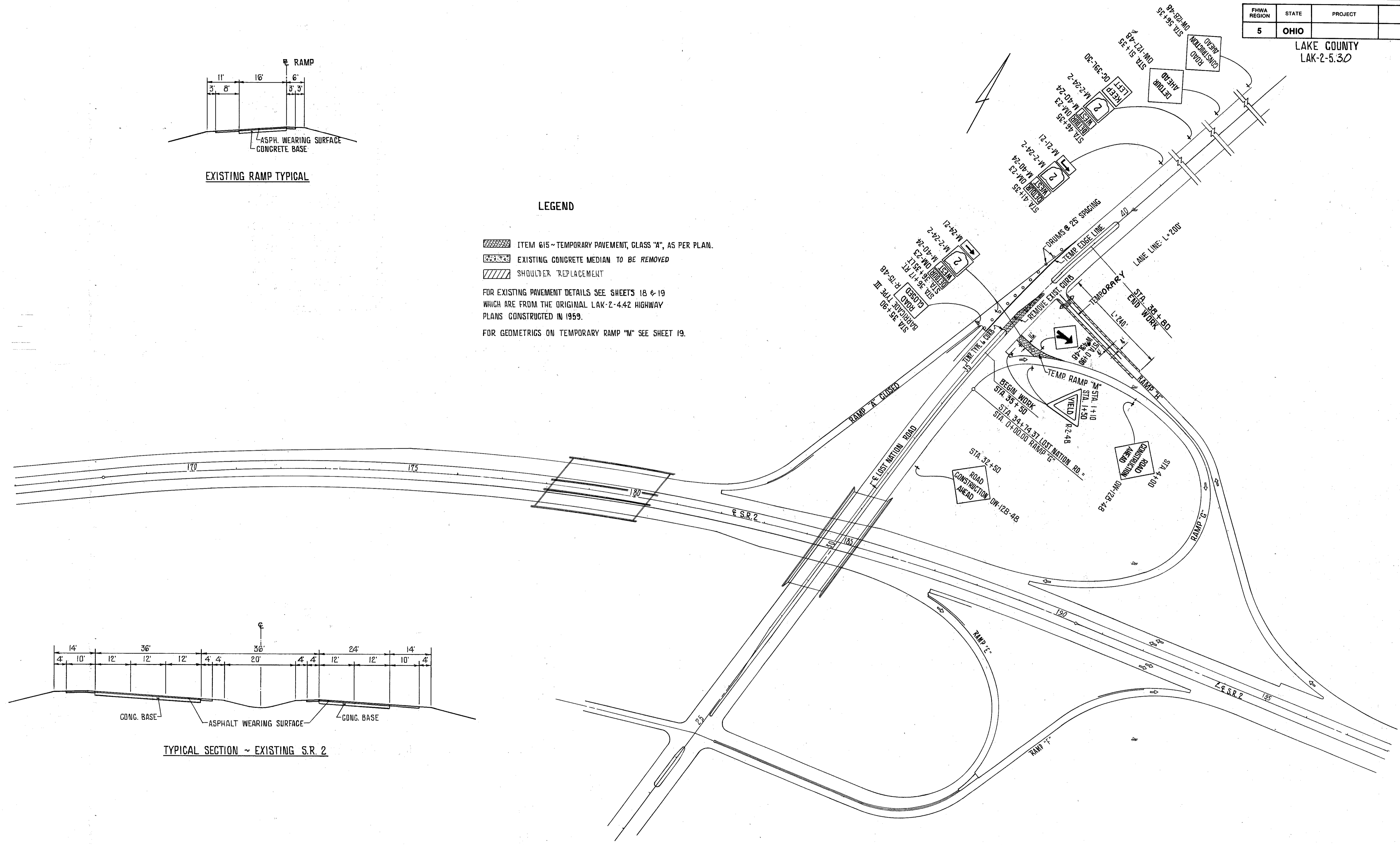

TYPICAL SECTION ~ EXISTING S.R. 2

NOTE:  
OVERHEAD GUIDE SIGNS ON SB LOST NATION ROAD FOR "WEST SR-2" SHALL BE COVERED AS DIRECTED BY THE ENGINEER.