

PLAN

⊕ DIMENSION 'A' SHALL NOT EXTEND BEYOND THE LIMITS OF THE SHOULDER (SHALL NOT FALL IN THE TRAFFIC LANE)

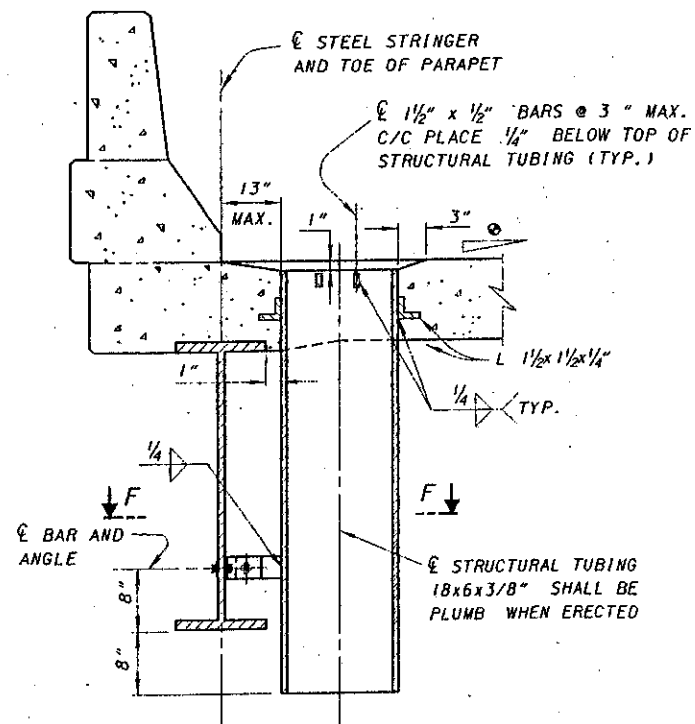

SECTION D-D

THE SCUPPERS SHALL BE LOCATED ON THE BRIDGE DECK BASED ON BRIDGE GEOMETRY AND THE CONTRIBUTING DECK DRAINAGE.

THE CONCRETE DECK, AT THE TWO SCUPPER CORNERS AWAY FROM THE CURB LINE, SHALL BE REINFORCED BY 3'-0" LONG #4 BAR, ONE BAR AT EACH CORNER, ORIENTED AT 45° TO THE SCUPPER.

⊕ SQUARE CUT TOP OF TUBE UNLESS DESIGNER SPECIFIES CROSS SLOPE GREATER THAN 1/2" PER FOOT IN WHICH CASE THE TOP IS TO BE CUT PARALLEL TO THE CROSS SLOPE.

⊕ SLOTTED HOLES SHALL BE 1/16" x 1 1/16". THE SLOT SHALL BE HORIZONTAL IN THE 3 x 3/8" BAR AND VERTICAL IN THE ANGLE. USE A 5/8" Ø A325 HIGH STRENGTH HEX HEAD BOLT WITH HEX NUT AND WASHERS, TIGHTEN AS PER CMS 513.15.

⊕ 5/8" Ø A325 TYPE 1 GALVANIZED FOR A GALVANIZED OR PAINTED BRIDGE AND A325 TYPE 3 FOR A588 WEATHERING STEEL BRIDGE. EACH ASSEMBLY SHALL INCLUDE A BOLT, NUT AND TWO (2) WASHERS, TIGHTENED PER CMS SECTION 513.15. FOR A GALVANIZED BRIDGE SYSTEM PROVIDED A 3.5" x 3.5" x 1/8" PREFORMED BEARING PAD WITH A 1 1/16" Ø HOLE AS PER CMS 711.21 BETWEEN THE BEAM WEB AND THE ANGLE. FIELD DRILL 1 1/16" DIAMETER HOLE IN THE WEB AFTER THE DECK CONCRETE HAS BEEN POURED.

THE SUPPORT ANGLES, BARS, SUPPORT BOLTS AND RELATED HARDWARE ARE INCLUDED WITH SCUPPERS FOR PAYMENT.

SCUPPERS INCLUDING SUPPORT ANGLES, BARS, BOLTS, NUTS AND WASHERS SHALL BE GALVANIZED IN ACCORDANCE WITH CMS 711.02.

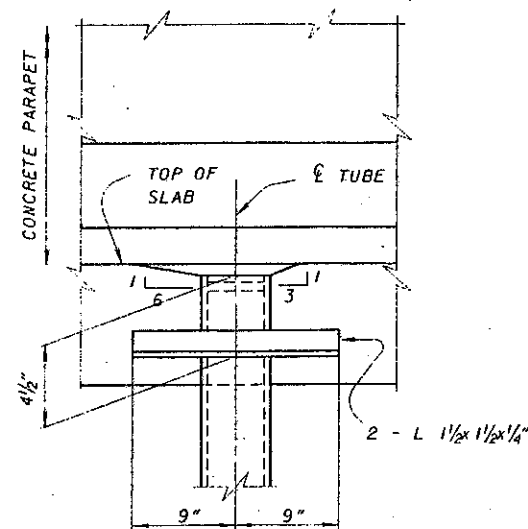

SECTION E-E

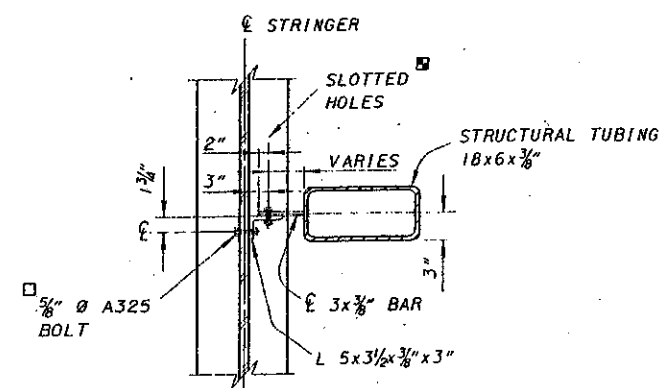

SECTION F-F

DESIGN AGENCY	OFFICE OF STRUCTURAL ENGINEERING
STATE OF OHIO DEPARTMENT OF TRANSPORTATION	DATE 2-12-97
ADMINISTRATOR	David Ingalls
DESIGNED	JCR
CHECKED	JS
APPROVED	WTL
STANDARD	GSD-1-96
REVISIONS	DRAWN JFF/FO
GENERAL STEEL DETAILS	
3	3