

APPROACH SLAB REPLACEMENT

ALL MATERIALS (INCLUDING BUT NOT LIMITED TO CLASS C CONCRETE, REINFORCING STEEL, DOWELS, AND PREFORMED EXPANSION JOINT FILLER WITH JOINT SEALER) AND LABOR REQUIRED FOR REPLACEMENT OF APPROACH SLABS AS INDICATED IN DETAILS ON SHEETS 10/20 AND 12/20 OF THE BRIDGE PLANS, SHALL BE INCLUDED FOR PAYMENT IN THE PRICE BID PER SQUARE YARD FOR ITEM 611 IN THE ROADWAY QUANTITIES.

ITEM 516 - STRUCTURAL EXPANSION JOINTS INCLUDING ELASTOMERIC STRIP SEALS

THIS ITEM SHALL CONSIST OF FURNISHING, FABRICATING, INSTALLING, CLEANING AND PAINTING STRUCTURAL STEEL EXPANSION JOINTS WITH ELASTOMERIC STRIP SEALS PER DRAWING EXJ-4-87 AND AS SHOWN ON SHEET 18/20.

DURING INSTALLATION OF THE ARMOR FOR THE SUPERSTRUCTURE SIDE OF THE EXPANSION JOINT SEAL, THE SEATING OF BEAMS ON BEARINGS SHALL BE CAREFULLY OBSERVED TO ASSURE THAT POSITIVE BEARING IS MAINTAINED. PROPER VERTICAL FIT OF THE ARMOR ON THE BEAMS SHALL BE ACHIEVED BY POSITIONING OF BEVEL FILL PLATES RATHER THAN BY CLAMPING FORCE.

THE JOINT OPENING VARIES WITH THE AMBIENT TEMPERATURE AT THE TIME OF CONSTRUCTION AND SHALL BE SET AS FOLLOWS:

TEMPERATURE	JOINT OPENING DIMENSION "A"
30° F	1 7/8"
40° F	1 3/4"
50° F	1 3/4"
60° F	1 5/8"
70° F	1 9/16"
80° F	1 1/2"
90° F	1 1/2"

A 3" JOINT SEAL SHALL BE FURNISHED BY ONE OF THE MANUFACTURES LISTED IN EXJ-4-87, OR AN APPROVED ALTERNATE, FOR USE IN THE EXPANSION JOINT. SEAL FOR EACH JOINT SHALL BE FURNISHED IN ONE CONTINUOUS PIECE.

DECK JOINT MATERIALS

STEEL FOR DECK JOINTS THAT IS TO BE FULLY ENCASED IN CONCRETE MAY BE UNPAINTED ASTM A36 OR A588. ALL OTHER STEEL PORTIONS OF THE JOINTS SHALL BE ASTM A588. STEEL SHALL BE ABRASIVELY CLEANED IN THE SHOP PRIOR TO FINAL ASSEMBLY. STEEL RETAINERS AND ELASTOMERIC STRIP SEALS SHALL BE PROVIDED BY THE SAME MANUFACTURER. A CLOSED-CELL ELASTOMERIC BACKER ROD SHALL BE INSTALLED IN RETAINERS BY THE JOINT FABRICATOR AFTER STEEL CLEANING TO PROTECT GROOVE SURFACES FROM CONTAMINATION PRIOR TO SEAL INSTALLATION OR FIELD PAINTING. SHOP PAINTING IS NOT REQUIRED.

ITEM SPECIAL - SEALING OF CONCRETE SURFACES, EPOXY-URETHANE

AN EPOXY-URETHANE SEALER SHALL BE APPLIED TO THE SURFACES SHOWN ON SHEETS, 9/20, 11/20, 13/20

SEE PROPOSAL NOTE FOR SEALER MATERIAL, SURFACE PREPARATION REQUIREMENTS, AND APPLICATION RATES AND PROCEDURES.

ITEM SPECIAL - SEALING OF CONCRETE SURFACES

SEALER SHALL BE APPLIED TO THE SURFACES SHOWN ON SHEETS, 11/20, 13/20, 14/20

SEE PROPOSAL NOTE FOR SEALER MATERIAL, SURFACE PREPARATION REQUIREMENTS, AND APPLICATION RATES AND PROCEDURES.

ITEM SPECIAL - POURED POLYURETHANE JOINT SEAL

I. DESCRIPTION: THIS WORK SHALL CONSIST OF SEALING JOINTS WITH POURED POLYURETHANE JOINT SEAL IN ACCORDANCE WITH THESE SPECIFICATIONS, IN REASONABLY CLOSE CONFORMITY WITH THE PLANS AND MANUFACTURER'S SPECIFICATIONS AND RECOMMENDATIONS AND AS DIRECTED BY THE ENGINEER.

II. MATERIAL: THE MATERIAL FOR THIS ITEM IS A TWO PART, COLD APPLIED, CHEMICALLY CURING, SELF LEVELING, ELASTOMERIC, POLYURETHANE JOINT SEALANT MEETING THE REQUIREMENTS OF FEDERAL SPECIFICATION TT-S-00227E AND ASTM C-920. ALL MATERIALS SHALL BE STORED AND INCORPORATED IN THE WORK AS SPECIFIED BY THE MANUFACTURER.

III. APPLICATION: THE CONCRETE SURFACES TO WHICH THE SEALER IS TO ADHERE SHALL FIRST BE THOROUGHLY CLEANED BY ABRASIVE BLASTING. POLYURETHANE JOINT SEAL SHALL BE POURED OVER THE FULL LENGTH OF THE BITUMEN IMPREGNATED FOAM SEAL PREVIOUSLY INSTALLED IN THE OPEN JOINT AND SHALL BE APPLIED ONLY WHEN THE CONCRETE IS DRY AND ITS TEMPERATURE IS ABOVE 50 DEGREES F. THE POURED JOINT SEALER SHALL ACT AS A SECOND SEAL UNDERNEATH AND ON TOP OF THE BITUMEN IMPREGNATED FOAM JOINT SEAL. THE INSTALLED AND CURED MATERIAL SHALL BE THE DEPTH AS SHOWN IN THE PLANS AND SHALL BE BONDED TO THE CONCRETE SIDES OF THE JOINT. ANY UNBONDED SECTION SHALL BE REMOVED AND REPLACED AT THE CONTRACTOR'S EXPENSE. DAMS AS REQUIRED TO CONTAIN THE POURED SEALER SHALL BE INCIDENTAL TO THIS ITEM OF WORK.

IV. METHOD OF MEASUREMENT: FOOTAGE UNDER THIS ITEM SHALL BE THE LINEAR FEET OF URETHANE JOINT SEAL POURED OVER THE FOAM JOINT SEAL THAT ARE COMPLETE, IN PLACE AND ACCEPTED.

V. BASIS OF PAYMENT: THE ACCEPTED QUANTITIES OF POURED POLYURETHANE JOINT SEAL SHALL BE PAID FOR AT THE CONTRACT UNIT PRICE FOR APPROACH SLABS AND PAYMENT SHALL BE IN FULL COMPENSATION FOR PREPARING THE SURFACES, FURNISHING AND PLACING ALL MATERIALS AND ALL OTHER MATERIAL, LABOR AND EQUIPMENT NECESSARY TO COMPLETE THE JOINT SEAL ACCORDING TO SPECIFICATIONS.

ITEM SPECIAL-JOINT SEAL (BITUMEN IMPREGNATED FOAM)

I. DESCRIPTION: THIS WORK SHALL CONSIST OF SEALING JOINTS USING BITUMEN IMPREGNATED FOAM IN ACCORDANCE WITH THESE SPECIFICATIONS, IN REASONABLY CLOSE CONFORMITY WITH THE PLANS AND MANUFACTURER'S SPECIFICATIONS AND RECOMMENDATIONS AND AS DIRECTED BY THE ENGINEER.

II. MATERIAL: THE MATERIAL SHALL BE A PRECOMPRESSED BITUMEN IMPREGNATED FOAM JOINT SEALANT SUCH AS EMSEAL PCSA, PERMABOND, ROYSTON UNIBAND 8100 OR AN APPROVED EQUAL. EMSEAL U.S.A., IS LOCATED AT 344 MILL ROAD IN STANFORD, CT. 06903 AND HAS A TELEPHONE NUMBER OF (203) 322-3828. PERMABOND IS AVAILABLE FROM PERMAQUIK (CANADA) LTD. WHICH IS LOCATED AT 3043 UNIVERSAL DRIVE IN MISSISSAUGA, ONTARIO L4X2E2; TELEPHONE (416) 625-9444. ROYSTON IS LOCATED AT 128 FIRST ST.; PITTSBURG, PA. 15238; TELEPHONE 828-1500.

ALL MATERIALS SHALL BE STORED AND INCORPORATED IN THE WORK AS RECOMMENDED BY THE MANUFACTURER.

III. SURFACE PREPARATION: THE FACES TO WHICH THE SEAL MUST ADHERE SHALL BE SANDBLASTED CLEAN AND BE FREE OF FOREIGN MATERIAL SUCH AS DIRT, DUST, GREASE, FORM OIL, RELEASE AGENTS AND ANY OTHER MATERIAL DETRIMENTAL TO ADHESION OF THE SEALANT.

IV. APPLICATION: JOINT SEALS SHALL BE INSTALLED ONLY WHEN THE SURFACES ARE DRY AND THE SURFACE TEMPERATURE IS ABOVE 50° F. BOTH CONCRETE SURFACES ADJACENT TO THE JOINT SEAL SHALL BE PRIMED AS RECOMMENDED BY THE MANUFACTURER. THE FOAM SEAL SHALL BE REMOVED FROM THE PACKAGING AND ITS NARROW EDGE INSERTED INTO THE JOINT OPENING. THE DEPTH FACE WITH THE SELF-ADHESIVE BACKING SHALL BE PRESSED AGAINST ONE SIDE OF THE JOINT SO THAT FOAM IS HELD IN PLACE WHILE IT RECOVERS.

AT TEMPERATURES ABOVE 70° F THE MATERIAL WILL RECOVER IN A FEW HOURS. AT TEMPERATURES BELOW 70° F THE RECOVERY SHALL BE ACCELERATED BY HEATING THE MATERIAL WITH AN OPEN FLAME, GAS BURNER, INFRA-RED LAMP OR HOT-AIR BLOWER.

A CONTINUOUS LENGTH OF JOINT SEAL SHALL BE ACHIEVED BY JOINING INDIVIDUAL STRIPS ONLY BY MEANS OF SCARFED JOINTS CUT AT 45 DEGREES OR LESS RELATIVE TO THE SIDES OF THE JOINT: THE SCARFED ENDS MUST BE PUSHED WELL PAST ONE ANOTHER. THE SEAL SHALL NOT BE PULLED OR STRETCHED SO THAT GAPS BETWEEN SUCCESSIVE LENGTHS ARE PREVENTED.

V. METHOD OF MEASUREMENT: FOOTAGE UNDER THIS ITEM SHALL BE THE LINEAR FEET OF BITUMEN IMPREGNATED FOAM INSTALLED IN THE OPEN JOINTS THAT ARE COMPLETE, IN PLACE AND ACCEPTED.

VI. BASIS OF PAYMENT: THE ACCEPTED QUANTITIES OF SEALED JOINTS SHALL BE PAID FOR AT THE CONTRACT UNIT PRICE FOR APPROACH SLABS WHICH PRICE AND PAYMENT SHALL BE FULL COMPENSATION FOR PREPARING THE SURFACES, FURNISHING AND PLACING ALL MATERIALS AND ALL LABOR AND EQUIPMENT NECESSARY TO COMPLETE THE JOINT SEAL ACCORDING TO SPECIFICATIONS.

ITEM 601 - SLOPE PROTECTION MISC.: GROUT FILLED FABRIC MATS

EMBANKMENT SLOPE PROTECTION EXTENDING FROM THE FACE OF THE ABUTMENT DOWN TO THE TOE OF SLOPE SHALL BE AS SPECIFIED IN ITEM 601.05 OF THE CONSTRUCTION AND MATERIAL SPECIFICATION EXCEPT AS MODIFIED HEREIN. THE FOLLOWING SHALL BE CONSIDERED AS SUPPLEMENTAL TO THE PROVISIONS SET FORTH THEREIN.

EXCAVATION OF EXISTING CRUSHED AGGREGATE SLOPE PROTECTION TO A DEPTH NECESSARY TO ESTABLISH A PROPER SUBGRADE DEPTH WHICH WILL ACCEPT THE PROPOSED SIX INCH THICK CONCRETE SLOPE PROTECTION. THE EXISTING CRUSHED AGGREGATE NEED NOT BE REMOVED IN ITS ENTIRETY; HOWEVER, THE CONTRACTOR SHALL GRADE THE REMAINING CRUSHED AGGREGATE TO PROVIDE A UNIFORM PLANE FOR THE SUBGRADE. ADDITIONAL MATERIAL MEETING THE REQUIREMENTS OF ITEM 203 MAY BE REQUIRED, AS DIRECTED BY THE ENGINEER, TO FILL VOIDS BETWEEN THE CRUSHED AGGREGATE.

AT THE CONTRACTOR'S OPTION, THE ENTIRE TWELVE INCH LAYER OF CRUSHED AGGREGATE SLOPE PROTECTION MAY BE EXCAVATED AND REPLACED WITH EMBANKMENT THAT MEETS THE REQUIREMENTS OF 203 AND WILL BRING THE PROPOSED SUBGRADE TO SIX INCHES BELOW THE FINAL GRADE OF THE PROPOSED SLOPE PROTECTION. THIS ADDITIONAL EXCAVATION AND EMBANKMENT WORK MAY BE DONE AT NO ADDITIONAL COST TO THE STATE.

MATERIAL

THE MATERIAL USED FOR EMBANKMENT SLOPE PROTECTION SHALL CONSIST OF SPECIALLY-WOVEN MULTIPLE PANELS OF DOUBLE LAYER, OPEN SELVAGE NYLON FABRIC, JOINED IN A MAT CONFIGURATION SIMILAR TO "FABRIFORM" 8" FILTER POINT OR APPROVED ALTERNATE. THIS MAT SHALL BE FILLED WITH A GROUT CONSISTING OF A MIXTURE OF PORTLAND CEMENT, FINE AGGREGATE AND WATER SO PROPORTIONED AND MIXED AS TO PROVIDE A PUMPABLE SLURRY. POZZOLAN AND GROUT FLUIDIFIER MAY BE USED AT THE OPTION OF THE CONTRACTOR. THE MIX SHALL EXHIBIT A COMPRESSIVE STRENGTH OF 2,000 P.S.I. AT TWENTY-EIGHT DAYS WHEN MADE AND TESTED IN ACCORDANCE WITH A.S.T.M. C-31 AND C-39.

INSTALLATION

THE GROUT FILLED FABRIC MATS SHALL BE INSTALLED ON THE PREPARED SLOPE IN STRICT ACCORDANCE WITH MANUFACTURER'S RECOMMENDATIONS. THE SIDES AND BOTTOM OF THE GROUT FILLED FABRIC MATS SHALL TERMINATE IN ANCHOR TRENCHES. THE TOP OF THE GROUT FILLED FABRIC MATS SHALL TERMINATE AT THE ABUTMENTS AGAINST 2" PREFORMED EXPANSION JOINT FILLER. (SEE PLAN DETAIL ON SHEETS 31 & 33.

MEASUREMENT FOR PAYMENT

GROUT FILLED FABRIC MATS, AS PER PLAN WILL BE MEASURED BY THE SQUARE YARD OF FINISHED SURFACE COMPLETE IN PLACE.

BASIS OF PAYMENT

PAYMENT FOR ACCEPTED QUANTITIES, COMPLETE IN PLACE WILL BE MADE AT THE CONTRACT UNIT PRICE BID FOR:

ITEM	EXT.	UNIT	DESCRIPTION
601	21100	SQ. YD.	SLOPE PROTECTION MISC.: GROUT-FILLED FABRIC MATS

THIS PRICE SHALL BE FULL COMPENSATION FOR ALL MATERIALS, LABOR, EQUIPMENT AND INCIDENTALS NECESSARY TO COMPLETE THIS ITEM AS SPECIFIED.

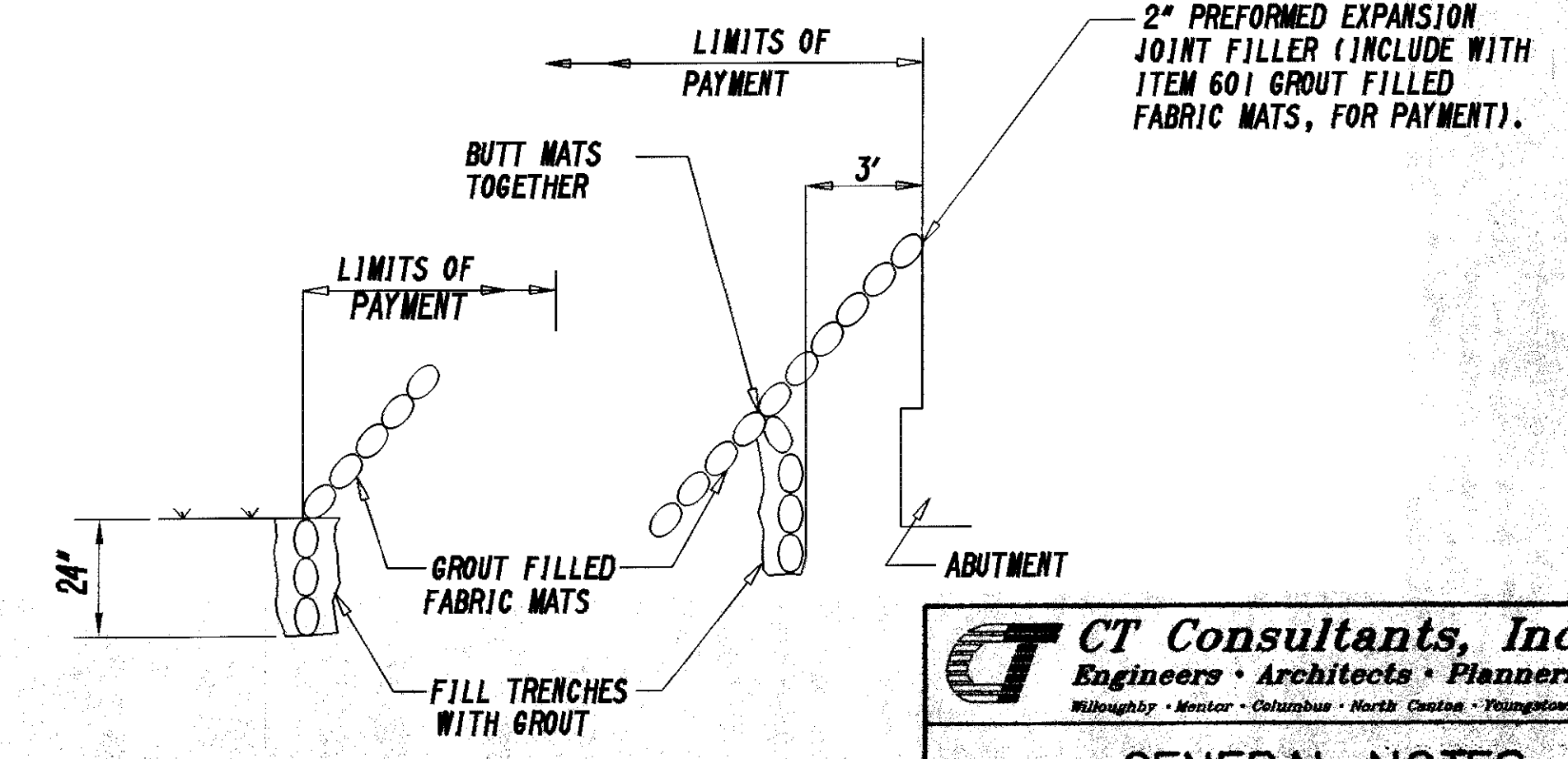

GROUT FILLED FABRIC MAT DETAIL

CT Consultants, Inc.
 Engineers • Architects • Planners
 5/20

GENERAL NOTES
 BRIDGE NO. LAK-2-0451
 S.R. 2 UNDER STEVENS BLVD.
 LAKE COUNTY

DESIGNED	DRAWN	TRACED	CHECKED	REVIEWED	DATE	REVISED
I.A.S.	I.A.S.	I.A.S.	J.P.R.	J.E.A.	2-25-94	