

o:\project\c000048a001\drawing\lak\13486\bridge\lak002_07601\sheets\002_07600\MD003.dgn 6/23/2008 5:28:03 PM troxberry

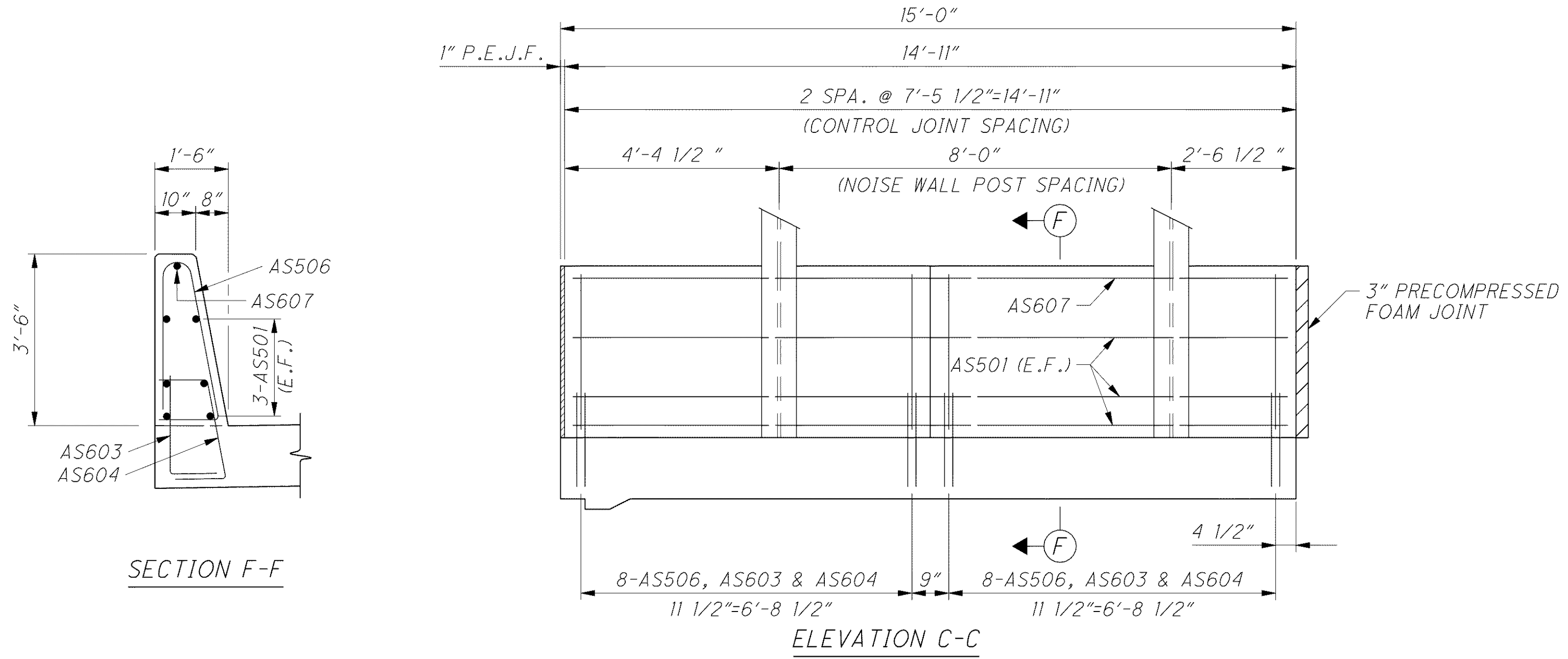

NOTES

1. FOR LIST OF ABBREVIATIONS SEE SHEET 4/25.
2. FOR BRIDGE TERMINAL ASSEMBLIES SEE ROADWAY STANDARD DRAWINGS GR-3.1 AND GR-3.2. SEE ROADWAY PLANS FOR DETAILS AND PAYMENT.
3. FOR NOISE WALL DETAILS SEE SHEET 976B OF 1679. INCLUDED WITH ROADWAY QUANTITIES FOR PAYMENT.

