

o:\project\cv000048a001\drawing\lak\13486\bridge\sheet\002_0542c\sheet\002_0542c\F003.dgn 6/24/2008 4:55:14 PM troxberry

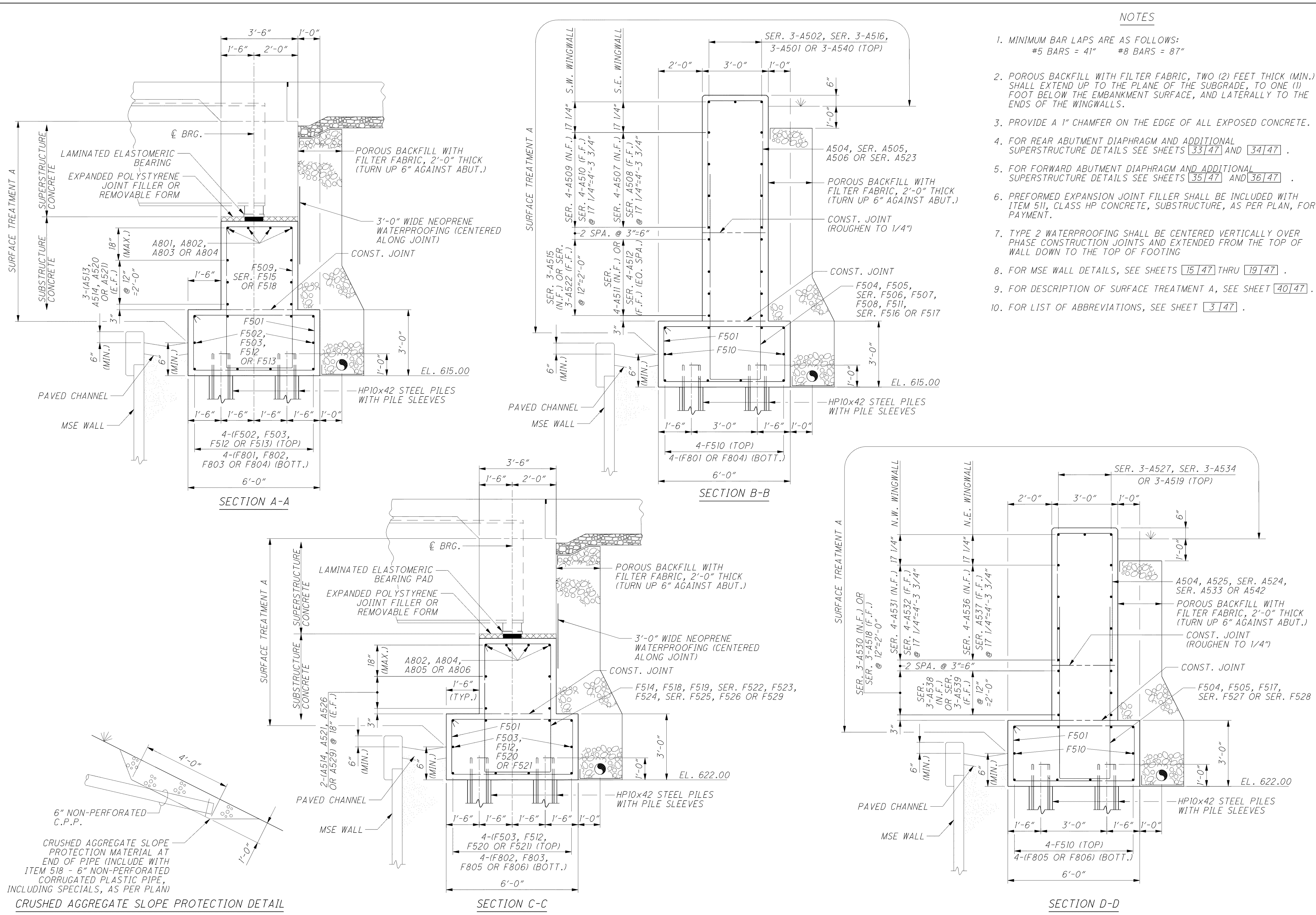

NOTES

1. MINIMUM BAR LAPS ARE AS FOLLOWS:
#5 BARS = 41" #8 BARS = 87"
2. POROUS BACKFILL WITH FILTER FABRIC, TWO (2) FEET THICK (MIN.) SHALL EXTEND UP TO THE PLANE OF THE SUBGRADE, TO ONE (1) FOOT BELOW THE EMBANKMENT SURFACE, AND Laterally TO THE ENDS OF THE WINGWALLS.
3. PROVIDE A 1" CHAMFER ON THE EDGE OF ALL EXPOSED CONCRETE.
4. FOR REAR ABUTMENT DIAPHRAGM AND ADDITIONAL SUPERSTRUCTURE DETAILS SEE SHEETS [33|47] AND [34|47].
5. FOR FORWARD ABUTMENT DIAPHRAGM AND ADDITIONAL SUPERSTRUCTURE DETAILS SEE SHEETS [35|47] AND [36|47].
6. PREFORMED EXPANSION JOINT FILLER SHALL BE INCLUDED WITH ITEM 511, CLASS HP CONCRETE, SUBSTRUCTURE, AS PER PLAN, FOR PAYMENT.
7. TYPE 2 WATERPROOFING SHALL BE CENTERED VERTICALLY OVER PHASE CONSTRUCTION JOINTS AND EXTENDED FROM THE TOP OF WALL DOWN TO THE TOP OF FOOTING
8. FOR MSE WALL DETAILS, SEE SHEETS [15|47] THRU [19|47].
9. FOR DESCRIPTION OF SURFACE TREATMENT A, SEE SHEET [40|47].
10. FOR LIST OF ABBREVIATIONS, SEE SHEET [3|47].

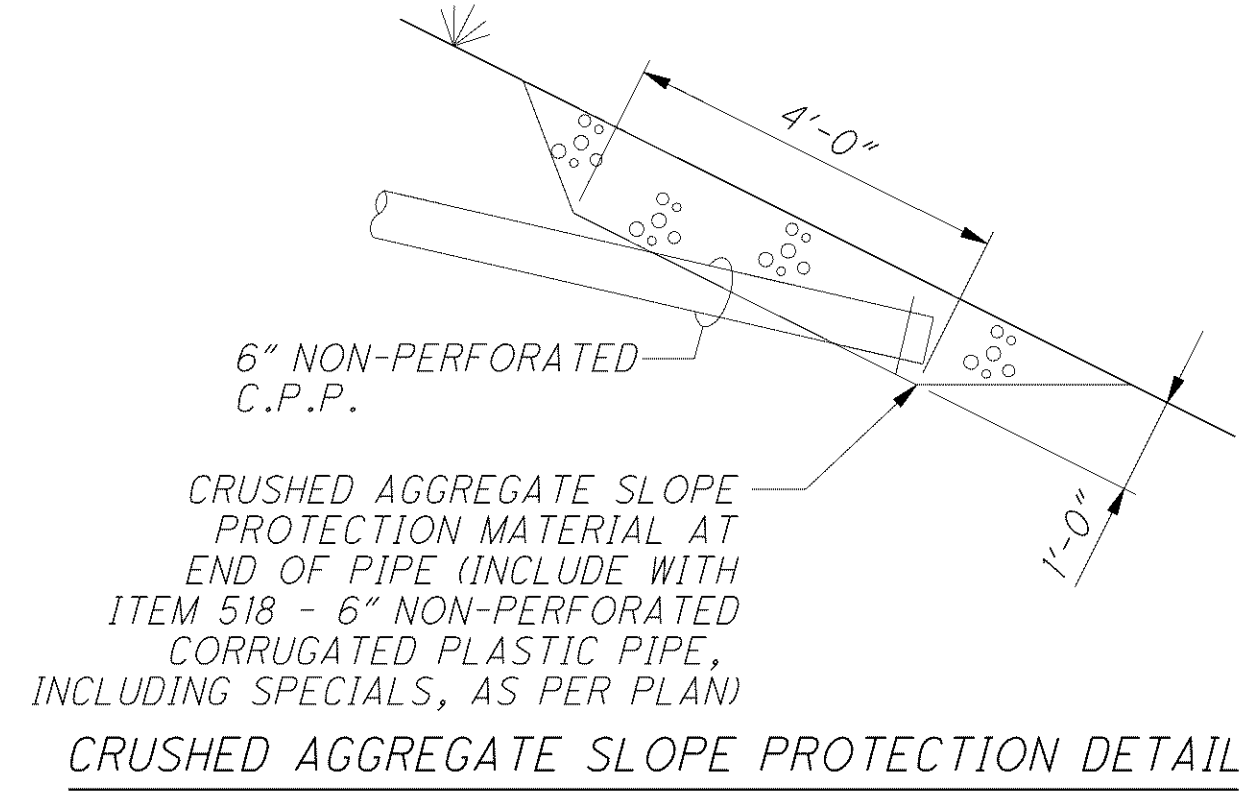

		DESIGN AGENCY ARCADIS ARCADIS U.S., Inc. 100 Superior Avenue, Suite 1250 Cleveland, Ohio 44114 Tel: 216-781-6244 Fax: 216-781-6245 www.arcadis-us.com			
DESIGNED	RBB	CHECKED	SKS	DATE	4/07
DRAWN	MPB	REVIEWED	CMD	STRUCTURE FILE NUMBER	4300823
ABUTMENT DETAILS BRIDGE NO. LAK-2-0542 LOST NATION ROAD OVER STATE ROUTE 2					
LAK-2-3.32 PID 13486					
25 / 47					
1571 1679					