

C:\Project\CV000048A001\Drawing\LAK\13486\bridge\LAK002\_0542C\sheets\002\_0542CMD006.dgn 6/26/2008 3:29:29 PM jufener

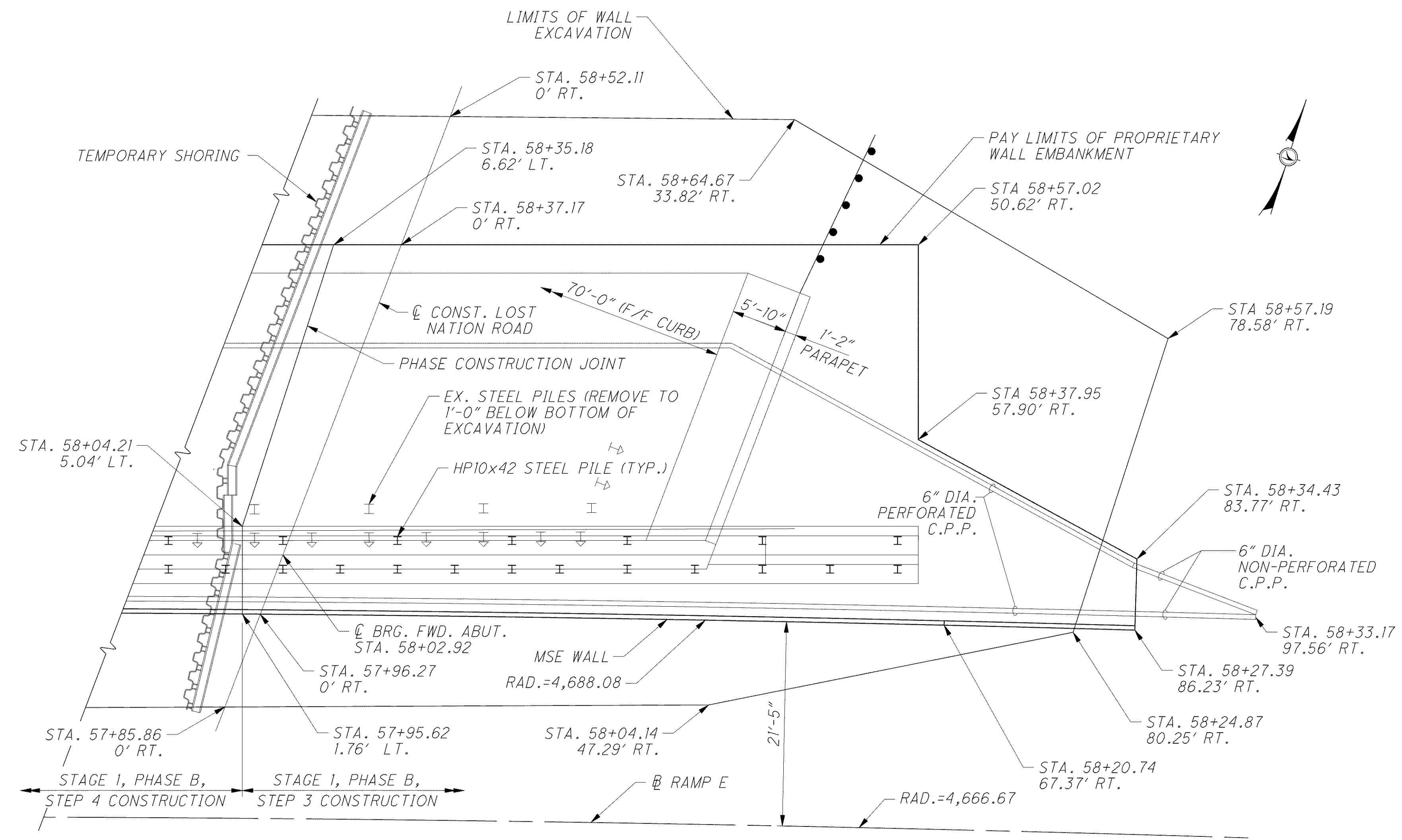

PLAN

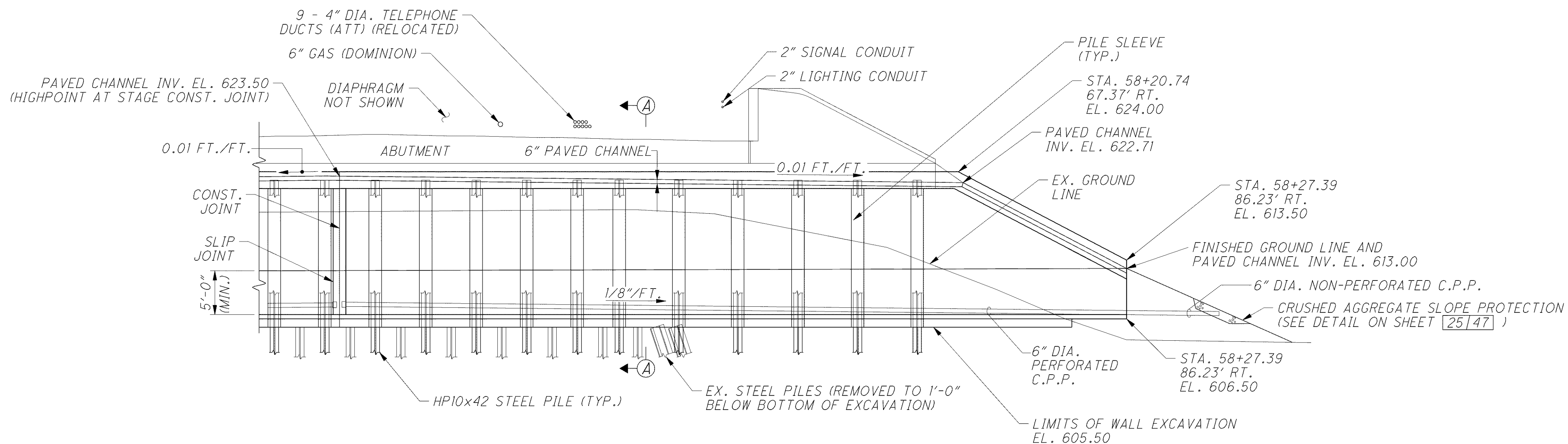

ELEVATION

NOTES

1. FOR TEMPORARY SHORING DETAILS SEE SHEETS [9]47 THRU [12]47 .
2. FOR FORWARD ABUTMENT DETAILS SEE SHEETS [23]47 , [24]47 AND [25]47 .
3. FOR ADDITIONAL MSE WALL DETAILS SEE SHEETS [18]47 AND [19]47 .
4. FOR AESTHETIC DETAILS, SEE SHEET [15]47 .
5. FOR LIST OF ABBREVIATIONS, SEE SHEET [3]47 .

DATE	4/07
REVIEWED	CMD
DRAWN	MPB
DESIGNED	RBB
CHECKED	SKS
STRUCTURE FILE NUMBER	4300823