

C:\Project\CV000048A001\Drawing\LAK\13486\bridge\LAK002\_0530L\_sheets\002\_0530CDP001.dgn 6/24/2008 5:06:49 PM mbechter

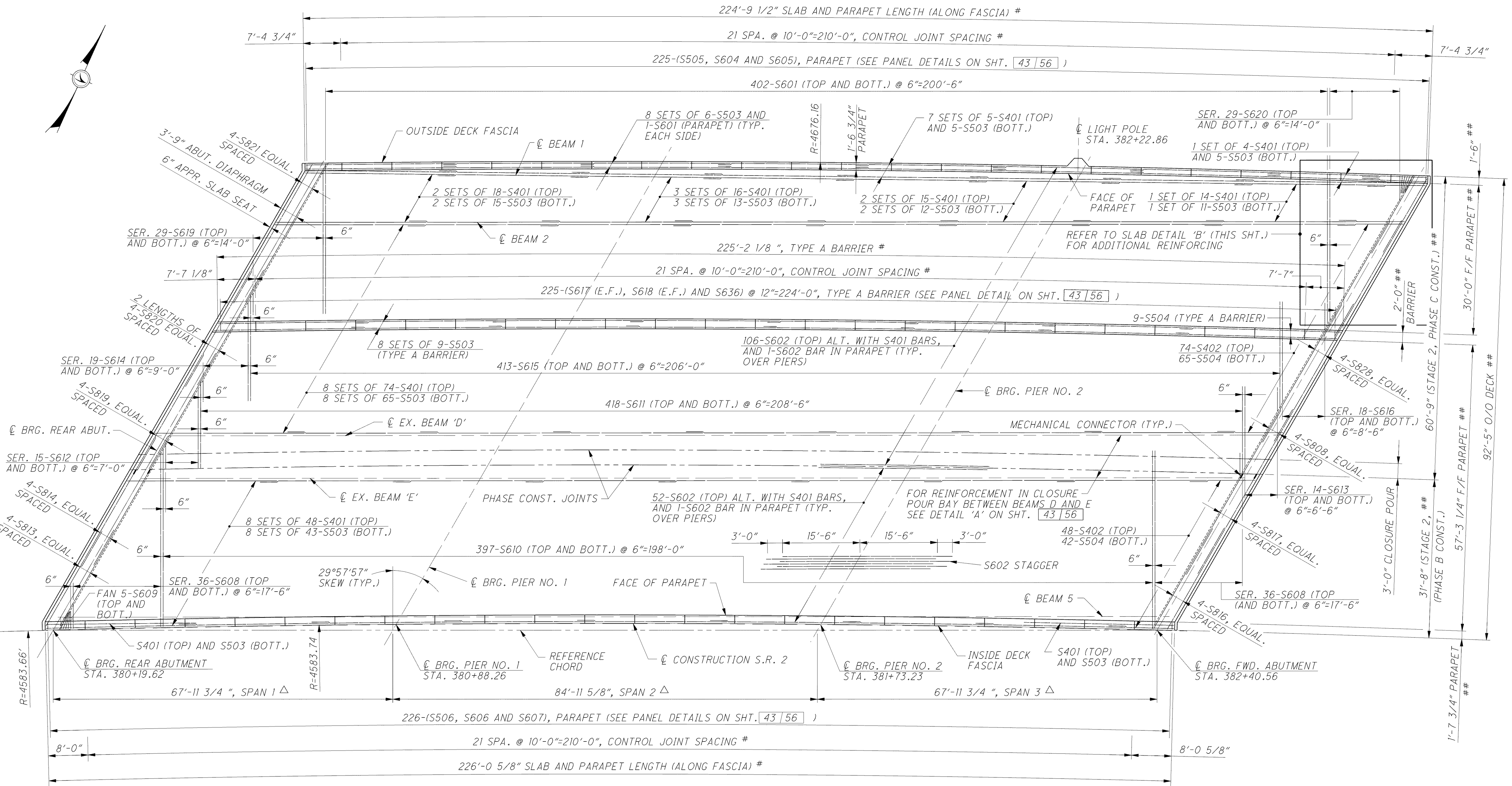
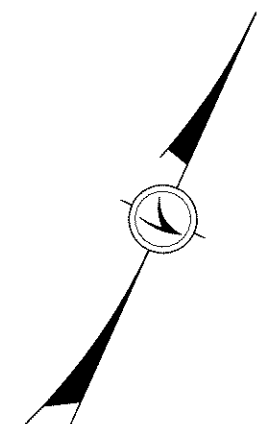

SLAB PLAN (LEFT STRUCTURE)

LEGEND

- △ MEASURED ALONG REFERENCE CHORD
- # MEASURED ALONG CURVE
- ## DENOTES RADIAL DIMENSION

NOTES

1. FOR CENTERLINE SCHEMATIC SEE SHEET [ 3 | 56 ] .
2. FOR FRAMING DETAILS AND NOTES SEE SHEETS [ 29 | 56 ] THRU [ 32 | 56 ] .
3. FOR TRANSVERSE SECTION INCLUDING LONGITUDINAL BAR SPACING SEE SHEET [ 40 | 56 ] .
4. FOR LIGHT POLE PILASTER DETAILS AND NOTES SEE SHEET [ 43 | 56 ] .
5. FOR SEMI-INTEGRAL ABUTMENT DIAPHRAGM DETAILS SEE SHEETS [ 35 | 56 ] THRU [ 39 | 56 ] .
6. FOR PARAPET AND BARRIER DETAILS SEE SHEET [ 40 | 56 ] .
7. MINIMUM BAR LAPS ARE AS FOLLOWS:  
#4 BARS = 31" #5 BARS = 38" #6 BARS = 46" #8 BARS = 87"
8. TRANSVERSE CONSTRUCTION JOINTS SHALL NOT BE PERMITTED IN THE DECK SLAB.
9. FOR SCREED TABLES SEE SHEETS [ 46 | 56 ] THRU [ 47 | 56 ] .
10. FOR LEGEND OF ABBREVIATIONS SEE SHEET [ 4 | 56 ] .

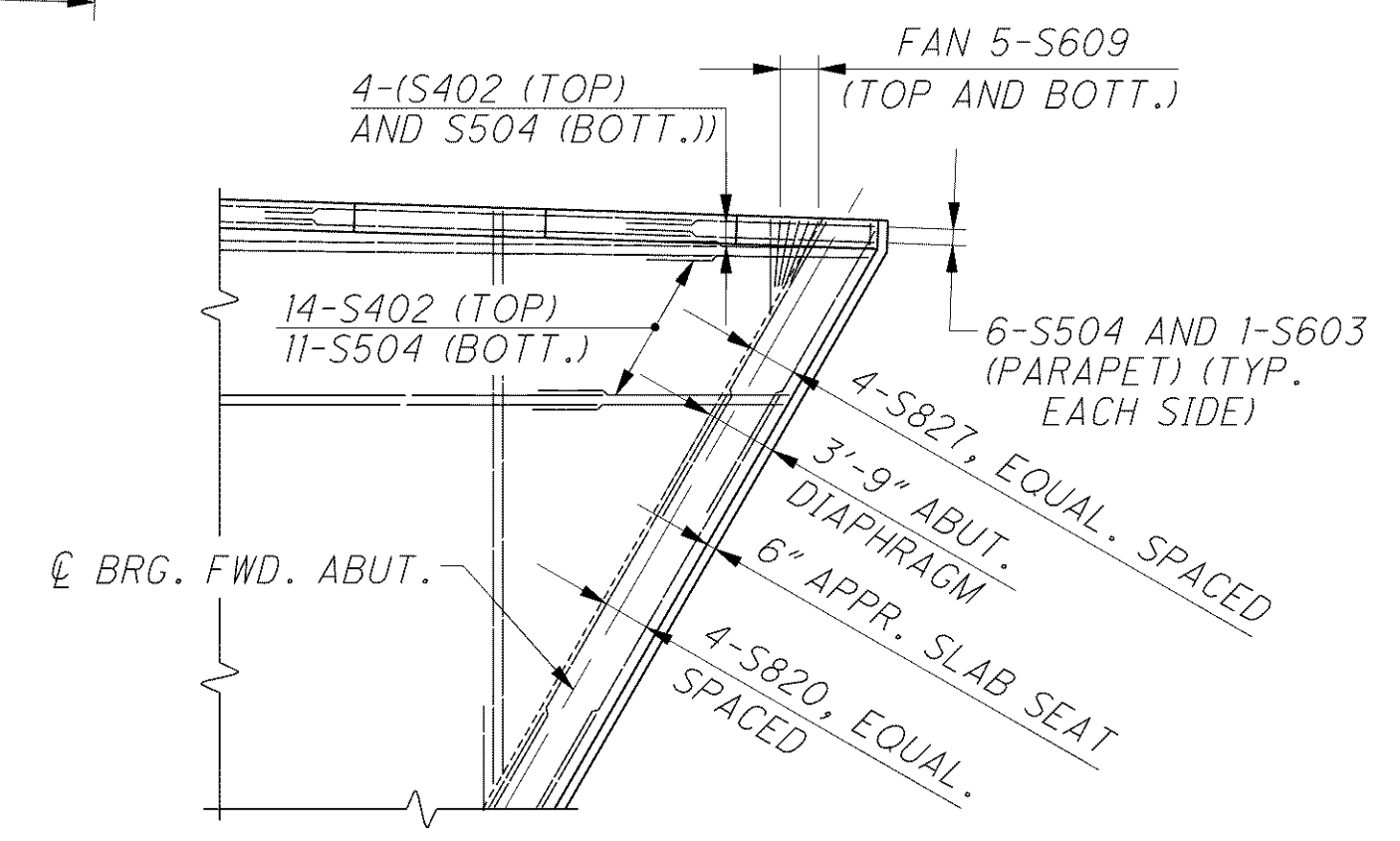

SLAB DETAIL 'B'

<p>DESIGN AGENCY ARCADIS U.S., Inc. 100 Superior Avenue, Suite 1250 Cleveland, Ohio 44114 Tel: 216-781-6225 Fax: 216-781-6245 www.arcadis-us.com</p>	<p>DATE 12/07</p> <p>REVIEWED RBB</p> <p>DRAWN CAF</p> <p>DESIGNED FJC</p> <p>STRUCTURE FILE NUMBER 4300750 (L)</p> <p>CHECKED RHC</p> <p>REVISED</p>
<p>SLAB PLAN</p> <p>BRIDGE NO. LAK-2-0530 L&amp;R</p> <p>STATE ROUTE 2 OVER CHAGRIN RIVER</p>	
<p>LAK-2-3.32</p> <p>PID 13486</p>	
<p>42 / 56</p> <p>1504</p> <p>1679</p>	