

j:\LAK\13486\bridge\LAK002\_0486c\sheets\002\_0486CRA002.dgn 03-JUL-2008 1:48PM lintn

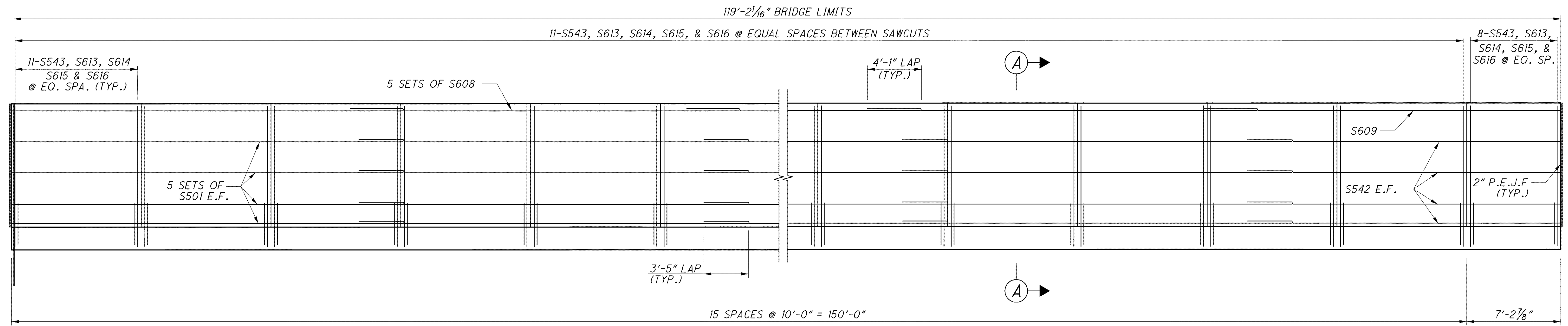

**MEDIAN PARAPET ELEVATION**

EASTBOUND MEDIAN PARAPET SHOWN  
(WESTBOUND MEDIAN PARAPET SIMILAR)

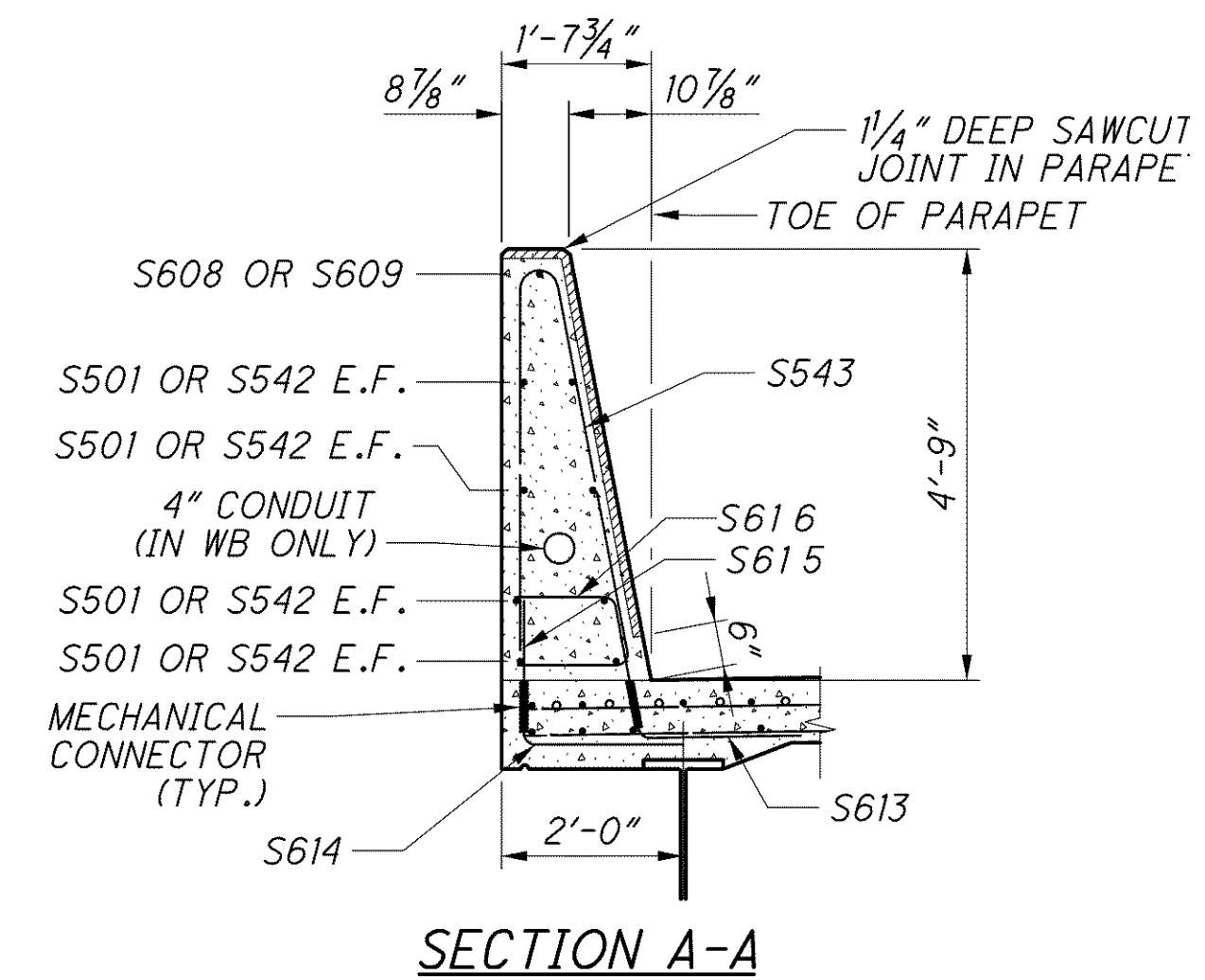

SECTION A-A

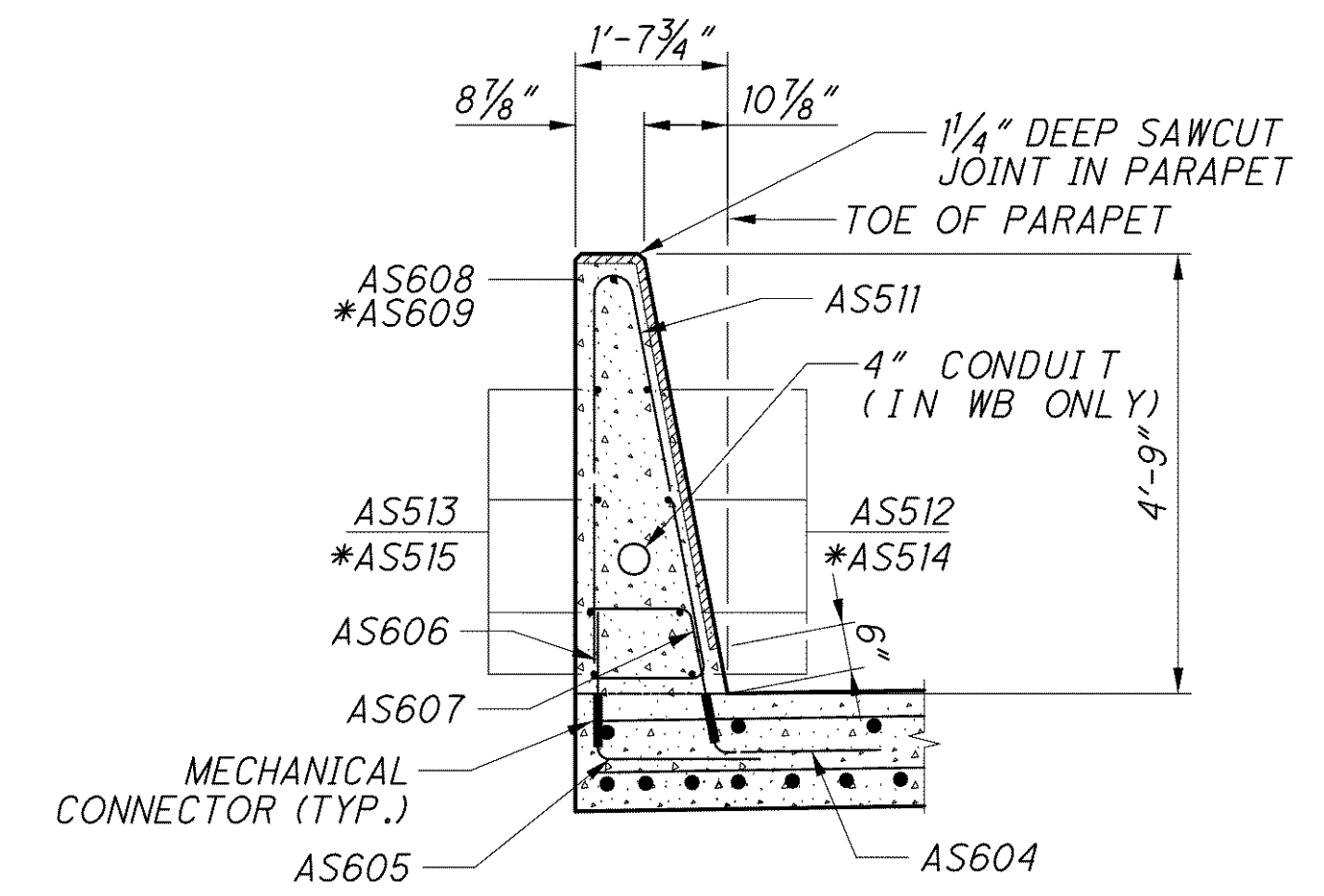

SECTION B-B

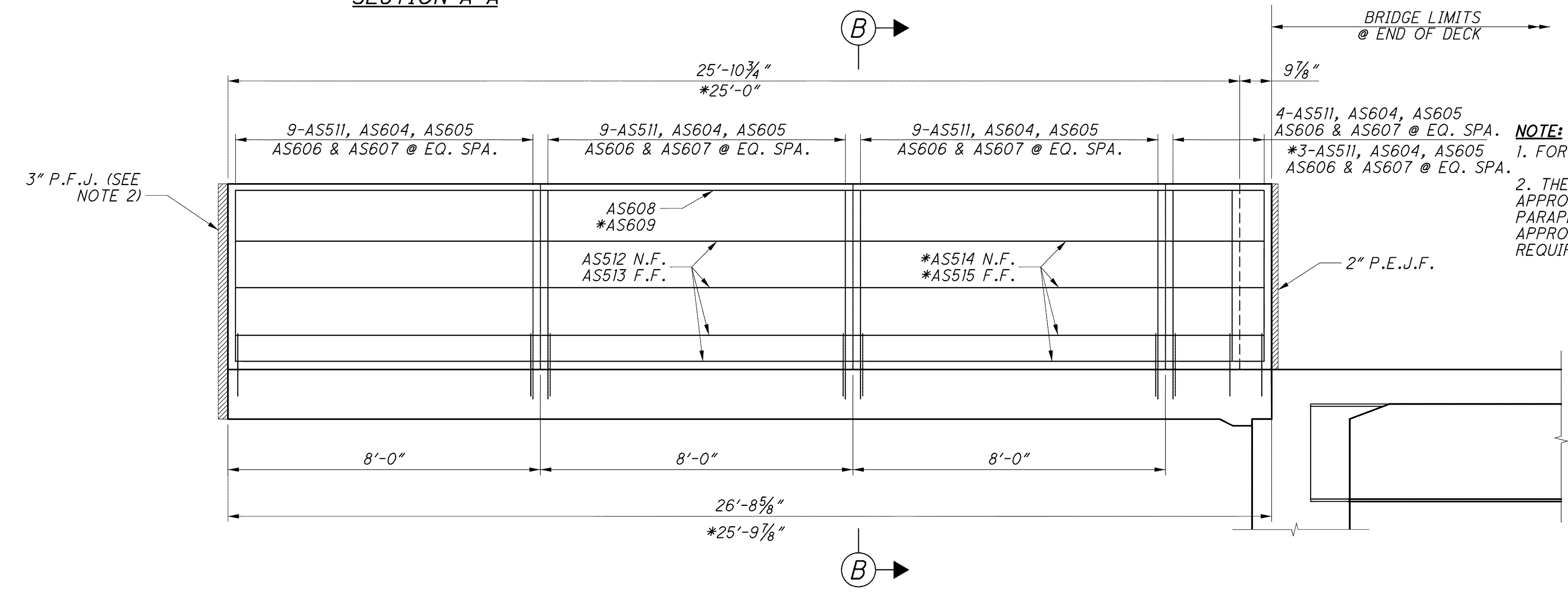

**MEDIAN APPROACH SLAB PARAPET ELEVATION**

WESTBOUND FWD. AND EASTBOUND REAR MEDIAN PARAPETS SHOWN  
(EASTBOUND FWD. AND WESTBOUND REAR MEDIAN PARAPETS SIMILAR)

**NOTE:**

1. FOR LIST OF ABBREVIATIONS SEE SHEET 4/70.
2. THE 3\"/>

\* APPLIES ONLY TO WESTBOUND MEDIAN PARAPET AT REAR ABUTMENT AND TO EASTBOUND MEDIAN PARAPET AT FORWARD ABUTMENT.

 <b>PARSONS BRINCKERHOFF</b> OMAHA & DOUGLAS, INC. 614 W. SUPERIOR AVE., SUITE 400 CLEVELAND, OHIO 44113	
DESIGNED	P.J.L.
CHECKED	EBS
DRAWN	B.K.J.
REVIEWED	R.J.O.
DATE	6-19-08
STRUCTURE FILE NUMBER	4300686 (L) 4300726 (R)
<b>PARAPET DETAILS (3 OF 3)</b> BRIDGE NO. LAK-2-0486 L&R STATE ROUTE 2 OVER ERIE ROAD	
<b>LAK-2-3.32</b> PID No. 13486	
60/70	
1452 1679	