

j:\LAK\13486\bridge\LAK002_0400C\sheets\02_0400CSD001.dgn 03-JUL-2008 1:44PM lintn

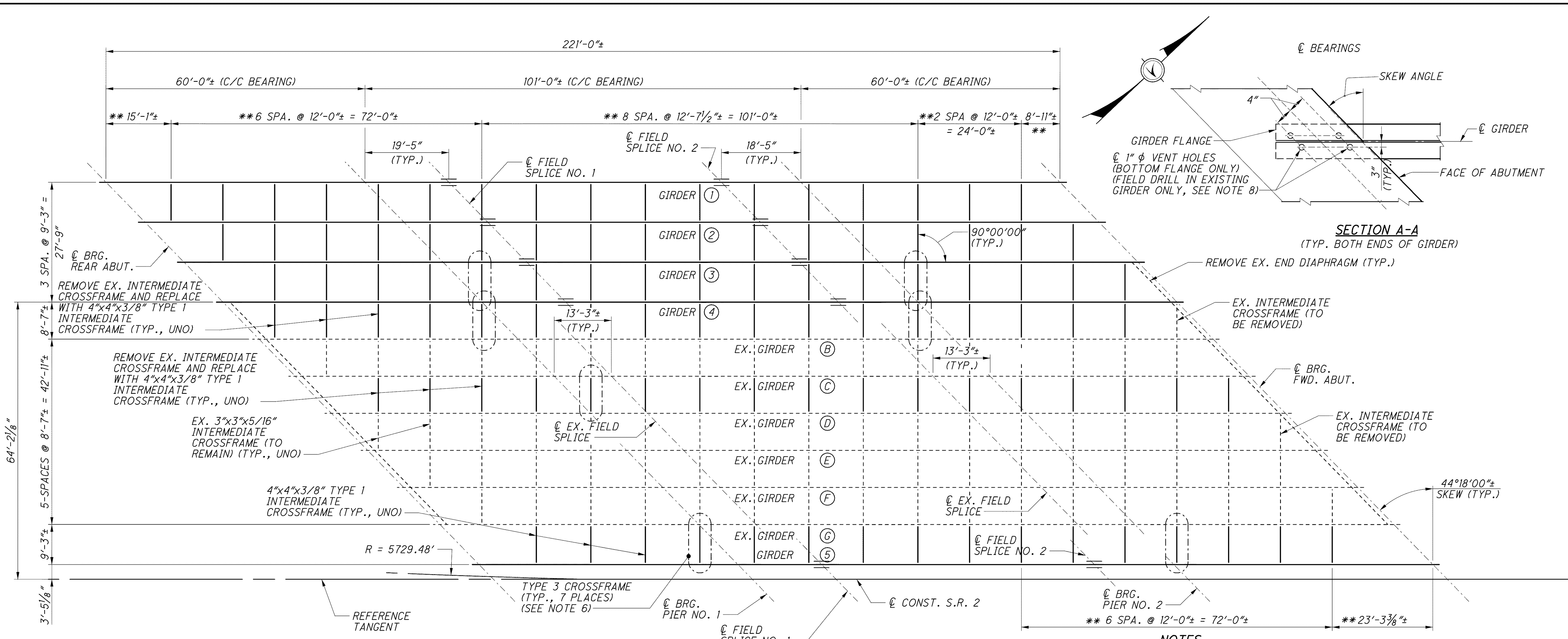

* FOR SHEAR STUD LOCATIONS ON SPLICE DETAIL, SEE TOP FLANGE SPLICE DETAIL ON SHEET 39/67.

** CONTRACTOR SHALL FIELD VERIFY DIMENSION PRIOR TO FABRICATION OF PROPOSED GIRDERS. SEE SHEET 3/67 FOR PAYMENT NOTE AND DETAILS.

FRAMING PLAN (LEFT STRUCTURE)

NOTES

- FOR FIELD SPLICE, CROSSFRAME, BEARING STIFFENER, & CONNECTION PLATE DETAIL, SEE SHEET 39/67.
- FOR SHEAR STUD DETAILS, SEE SHEET 40/67.
- CVN: WHERE A SHAPE OR PLATE IS DESIGNATED (CVN), FURNISH MATERIAL THAT MEETS THE MINIMUM NOTCH TOUGHNESS REQUIREMENTS AS SPECIFIED IN 711.01.
- WELD ATTACHMENT OF SUPPORTS FOR CONCRETE DECK FINISHING MACHINE TO AREAS OF THE FASCIA STRINGER FLANGES DESIGNATED "COMPRESSION". DO NOT WELD ATTACHMENTS TO AREAS DESIGNATED "TENSION". FILLET WELDS TO COMPRESSION FLANGES SHALL BE AT LEAST 1" FROM EDGE OF FLANGE, BE NO MORE THAN 2" LONG, AND BE AT LEAST 1/4" FOR THICKNESSES UP TO 3/4" OR 5/16" FOR GREATER THAN 3/4" THICK.
- ALL NEW STRUCTURAL STEEL SHALL BE PAINTED, EXCEPT FOR THE TOP OF THE TOP FLANGE OF THE GIRDERS. THIS SHALL INCLUDE THE GIRDERS, STIFFENERS, CONNECTIONS PLATES, CROSS FRAMES, SPLICE PLATES, BEARING STEEL, ETC. EXISTING STRUCTURAL STEEL SHALL ONLY BE FIELD PAINTED IN LOCATIONS WHERE NEW ATTACHMENTS ARE CONNECTED OR IN LOCATIONS WHERE EXISTING ATTACHMENTS ARE REMOVED. ALL PAINTING SHALL BE AS PER ITEM 514 AND FEDERAL COLOR NUMBER 595B-15450 (LIGHT BLUE).
- USE TYPE 3 CROSSFRAME WHERE PROPOSED LOCATION OF CROSSFRAME MATCHES EXISTING OR PROPOSED BEARING STIFFENER LOCATION AT EITHER END OF CROSSFRAME. FIELD WELD CONNECTION PLATE TO MATCH BEARING STIFFENER PLATE LOCATION.
- FOR LIST OF ABBREVIATIONS, SEE SHEET 4/67.
- THE 1" DIAMETER VENT HOLES SHALL BE DRILLED, FLAME CUTTING OF HOLES IS NOT PERMITTED. SHOP OR FIELD DRILLED HOLES SHALL BE INCLUDED WITH ITEM 516, ELASTOMERIC BEARING WITH INTERNAL LAMINATES AND LOAD PLATE, AS PER PLAN FOR PAYMENT.

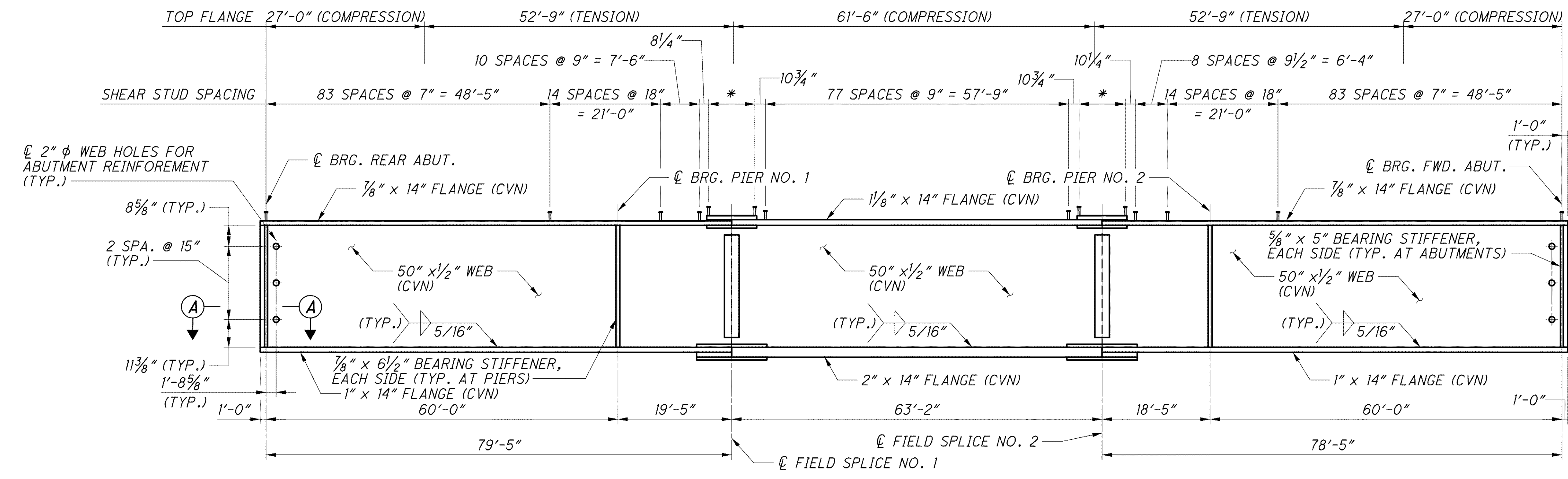

PROPOSED GIRDER ELEVATION