

j:\LAK\13486\bridge\LAK002\_0400C\sheets\02\_0400CP002.dgn 03-JUL-2008 1:36PM jintn

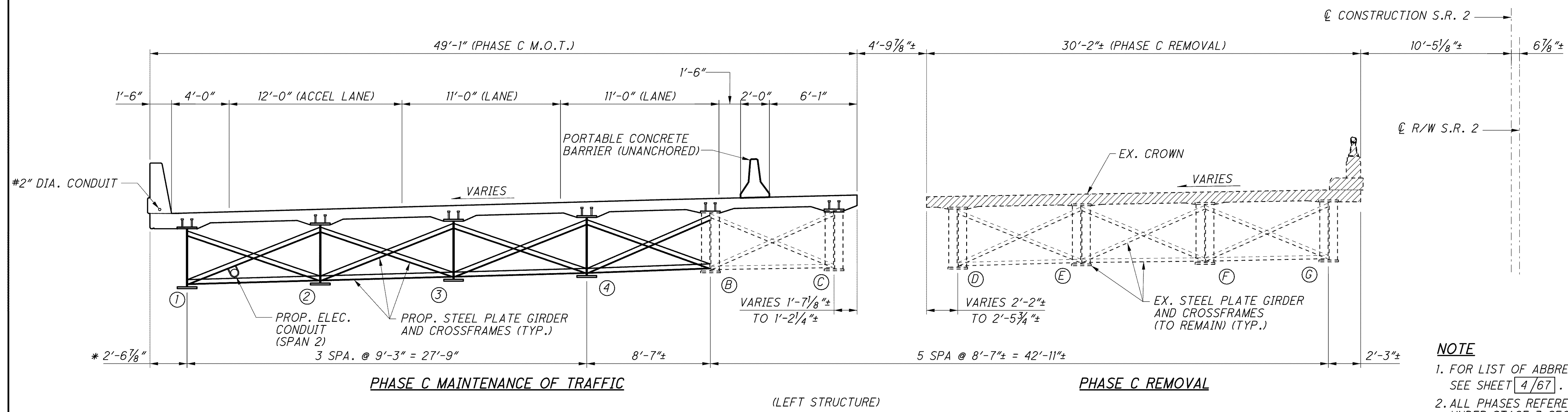

PHASE C MAINTENANCE OF TRAFFIC

(LEFT STRUCTURE)

PHASE C REMOVAL

NOTE

1. FOR LIST OF ABBREVIATIONS, SEE SHEET 4/67.
2. ALL PHASES REFERENCED ARE TO BE COMPLETED UNDER STAGE 3 SEQUENCE OF CONSTRUCTION, SEE MOT DRAWINGS.

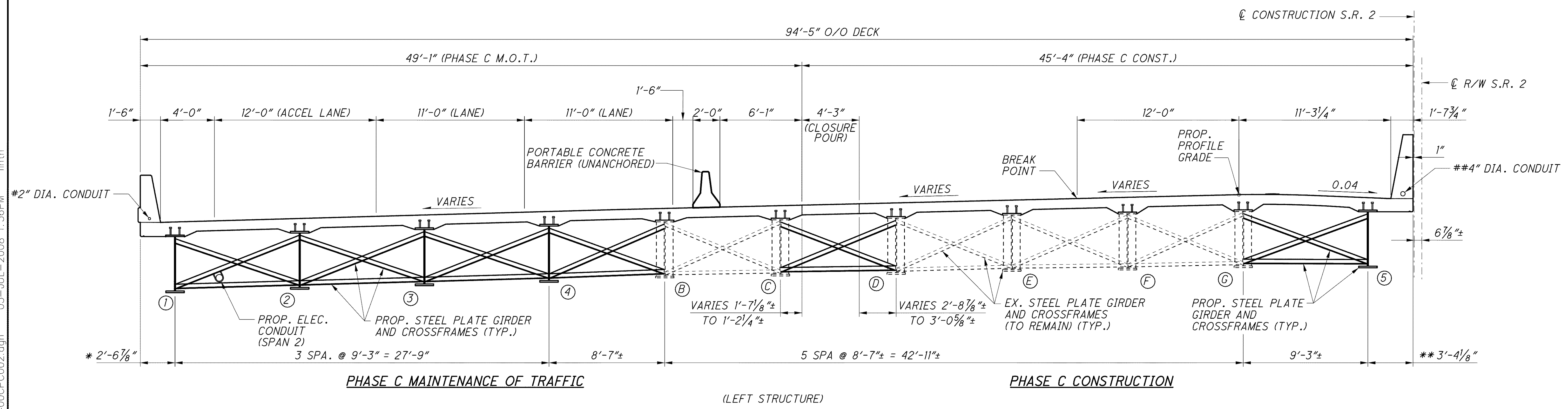

PHASE C MAINTENANCE OF TRAFFIC

(LEFT STRUCTURE)

PHASE C CONSTRUCTION

- \* VARIES FROM 3'-9 3/8" AT STA. 309+61.35 TO 2'-6 7/8" AT STA. 310+79.71
- \*\* VARIES FROM 3'-3 3/8" AT STA. 310+53.46 TO 3'-4 1/8" AT STA. 310+79.71
- # FROM STA. 311+31.57 TO END OF BRIDGE
- ## FULL LENGTH OF BRIDGE

PHASE C BRIDGE CONSTRUCTION (LEFT BRIDGE)

1. REMOVE EXISTING MEDIAN SECTION OF DECK AND PARAPET.
2. REMOVE PORTION OF ABUTMENT AND APPROACH SLAB.
3. BUILD ABUTMENT AND PIER EXTENSIONS.
4. ERECT GIRDER 5 AND CROSSFRAMES.
5. PLACE ABUTMENT DIAPHRAGMS.
6. PLACE DECK AND PARAPETS.
7. REPLACE REMOVED EXISTING CROSSFRAMES BETWEEN GIRDERS C AND D.
8. PLACE ABUTMENT DIAPHRAGMS AND DECK CLOSURE POUR.
9. SET UP FOR PHASE D MOT.