

NOTES:

1. FOR ADDITIONAL NOTES AND DETAILS, SEE SHEET [29/44].

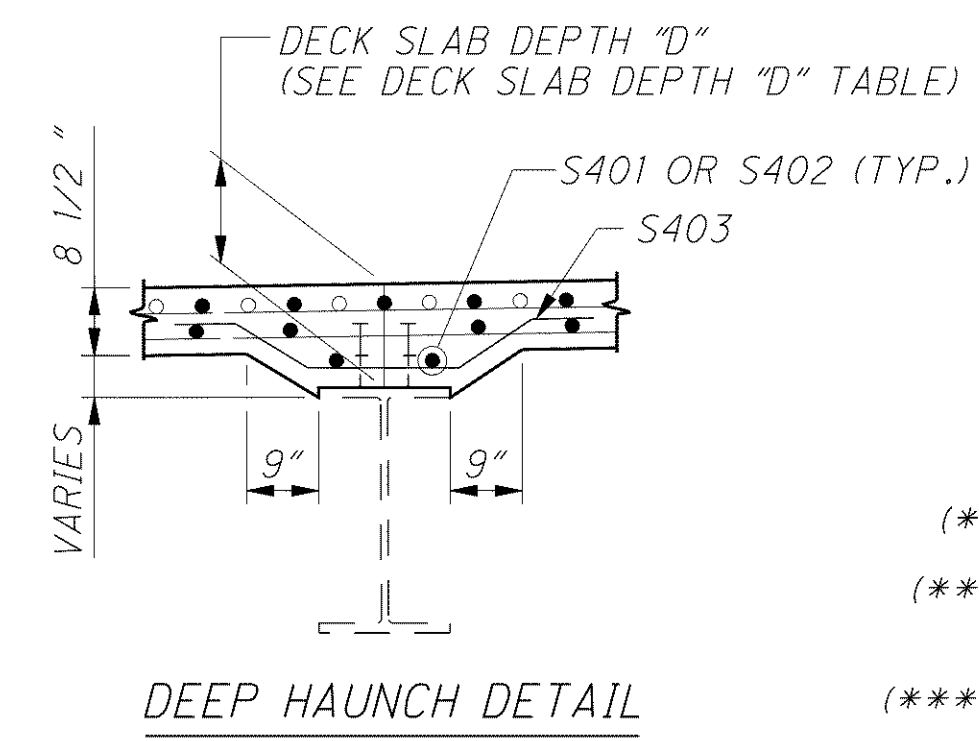

- LEGEND**
- (*) - INCLUDE WITH ROADWAY QUANTITIES FOR PAYMENT.
 - (**) - 4-S401 AND 70-S403 BARS PLACED IN HAUNCH THRU SPAN 1, LAP S403 WITH BOTTOM MATT #5 BARS
 - (***) - 8-S401, 2-S402 AND 260-S403 BARS PLACED IN HAUNCH THRU ENTIRE BRIDGE LIMITS LAP S403 WITH BOTTOM MATT #5 BARS

DECK SLAB DEPTH "D" TABLE (LEFT STRUCTURE) (INCHES)

DESCRIPTION	BEAMS									
	1	A	B	C	D	E	F (**)	G (**)	2	3
☉ BRG. REAR ABUT.	10 5/8	12 1/8±	12 1/8±	12±	12 1/2±	12 1/2±	14 3/8±	14 3/8±	13	11 5/8
1/2 POINT	10 5/8	11 1/2±	11 1/2±	11 1/2±	11 3/4±	11 7/8±	13 5/8±	13 3/4±	13 1/4	11 7/8
☉ BRG. & PIER NO. 1	10 5/8	10 3/4±	10 3/4±	10 7/8±	10 7/8±	11±	12 7/8±	13±	12 3/4	11 1/2
1/4 POINT	11	10 5/8±	10 3/4±	10 7/8±	11±	11±	12 7/8±	12 7/8±	13	11 3/4
1/2 POINT	11 1/4	10 3/8±	10 5/8±	10 7/8±	11±	11±	12 3/4±	12 3/4±	13 1/8	11 7/8
3/4 POINT	11	10 5/8±	10 1/2±	10 3/4±	11±	10 3/4±	12 5/8±	12 5/8±	12 3/4	11 1/2
☉ BRG. & PIER NO. 2	10 5/8	10 1/8±	10 1/4±	10 1/2±	10 7/8±	10 1/2±	12 3/8±	12 3/8±	12 1/4	11
1/2 POINT	10 5/8	10 5/8±	10 5/8±	10 7/8±	11±	11±	12 3/4±	12 7/8±	12 1/2	11 3/8
☉ BRG. FWD. ABUT.	10 5/8	11±	11±	11 1/8±	11 1/8±	11 3/8±	13 1/8±	13 1/4±	12 1/8	11

DECK SLAB DEPTH "D" TABLE (RIGHT STRUCTURE) (INCHES)

DESCRIPTION	BEAMS									
	4	5 (***)	H (**)	J (***)	K	L	M	N	P	6
☉ BRG. REAR ABUT.	13 1/8	13 7/8	14 3/4±	15±	12 3/4±	12 5/8±	12 5/8±	12 5/8±	12 3/4±	10 5/8
1/2 POINT	13 1/4	14 1/8	14 1/8±	14 1/4±	12 1/8±	12 1/4±	12 1/8±	11 1/2±	11 1/2±	10 5/8
☉ BRG. & PIER NO. 1	12 3/4	13 1/2	13 3/8±	13 1/2±	11 3/8±	11 3/4±	11 1/2±	10 3/8±	10 1/4±	10 5/8
1/4 POINT	13	13 7/8	13 3/8±	13 1/2±	11 1/2±	11 3/4±	11 1/2±	10 5/8±	10 5/8±	11
1/2 POINT	13	13 7/8	13 1/4±	13 1/2±	11 1/2±	11 5/8±	11 1/2±	10 7/8±	11±	11 1/4
3/4 POINT	12 5/8	13 1/2	13 1/4±	13 1/4±	11 3/8±	11 3/8±	11 3/8±	11±	11 1/8±	11
☉ BRG. & PIER NO. 2	12	13	12 7/8±	13±	11 1/4±	11 1/8±	11 1/8±	11±	11 1/4±	10 5/8
1/2 POINT	12 1/8	13 1/8	13 1/4±	13 1/2±	11 1/2±	11 3/8±	11 3/8±	11 1/4±	11 3/8±	10 5/8
☉ BRG. FWD. ABUT.	11 5/8	12 1/2	13 1/2±	13 7/8±	11 3/4±	11 1/2±	11 5/8±	11 3/8±	11 1/2±	10 5/8

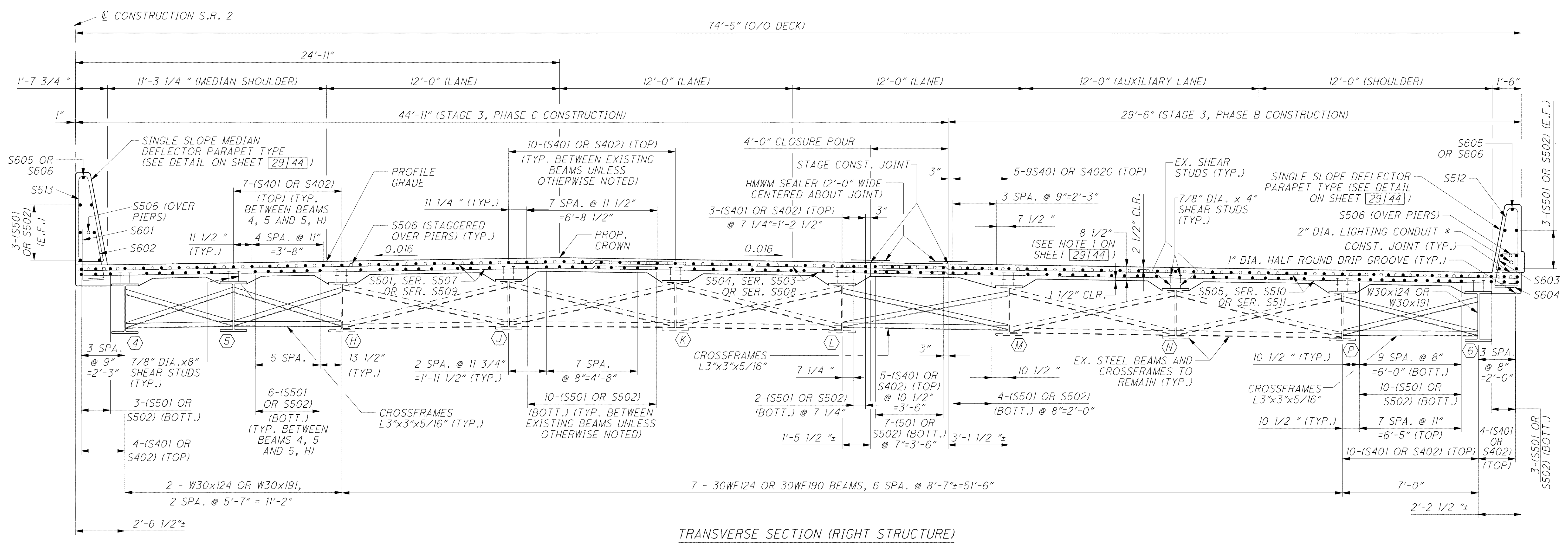

TRANSVERSE SECTION (RIGHT STRUCTURE)

o:\project\c000048a001\drawing\lak_13486\bridge\ok002_0363\sheet\002_0363\CTS002.dgn 6/24/2008 3:59:38 PM troxberry