

MICROFILMED
JUL 8 1986

FED. RD. DIVISION	STATE	PROJECT	293 384
2	OHIO		

LAKE COUNTY
SEC. LAK-2-14.22

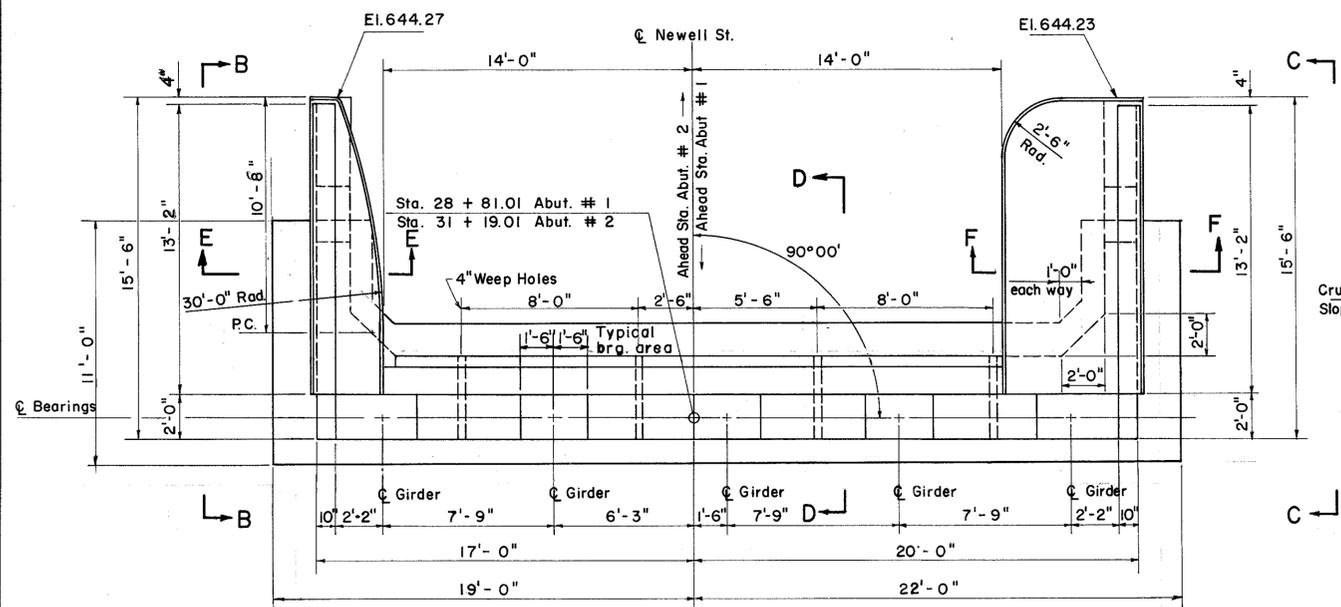

PLAN OF ABUTMENT # 2 - SHOWN
PLAN OF ABUTMENT # 1 - OPPOSITE

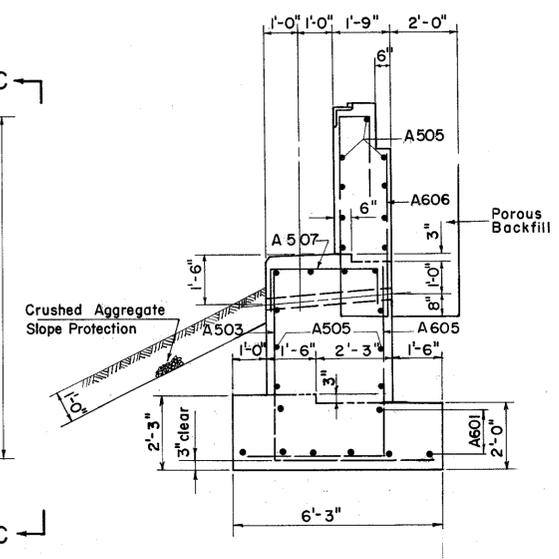

SECTION D-D

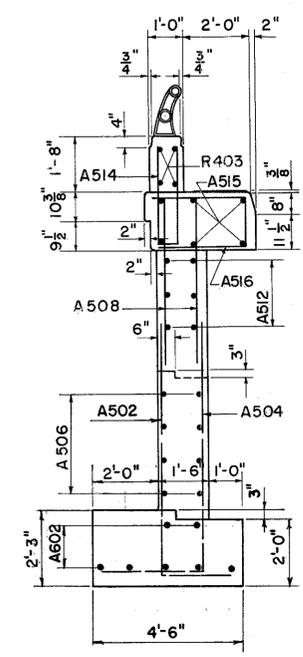

SECTION E-E

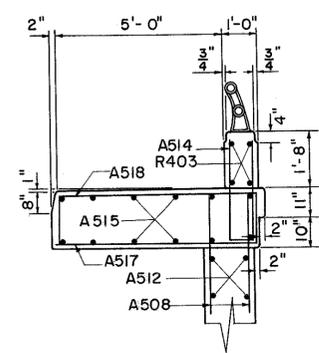

SECTION F-F
(OPP. SECTION E-E EXCEPT AS SHOWN)

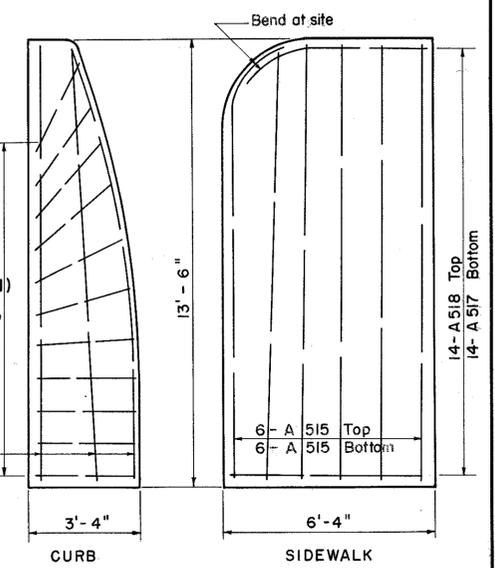

REINFORCING PLANS

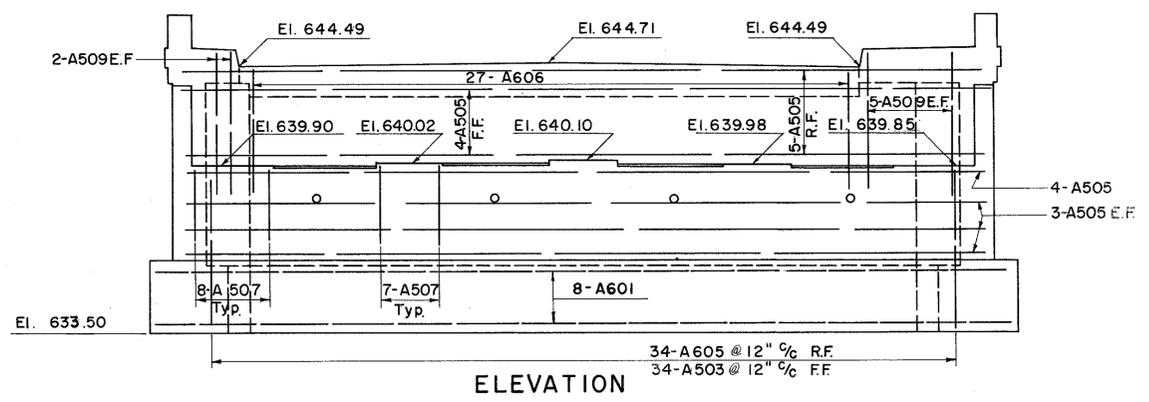

ELEVATION

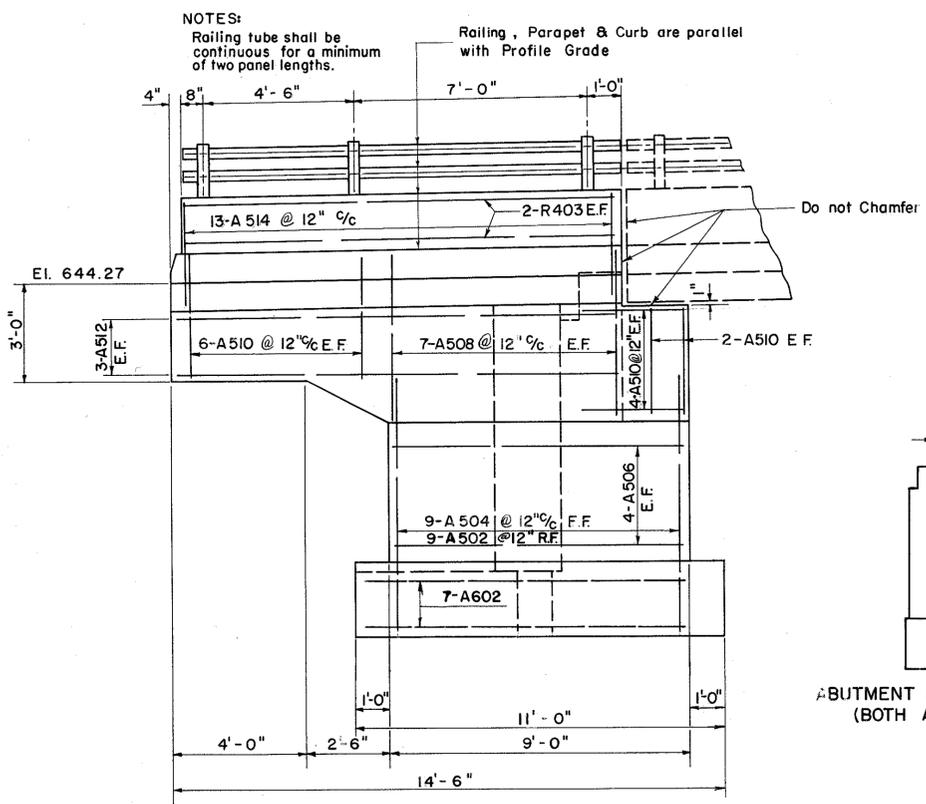

ELEVATION B-B - SHOWN
ELEVATION C-C - OPPOSITE

NOTES:
Reinforcing Steel shall have a minimum of 3" of cover in the bottom of the footing and 2" elsewhere.
F.F. denotes Front Face
R.F. denotes Rear Face
E.F. denotes Each Face

PREPARED BY
CAPITOL ENGINEERING ASSOCIATES, DILLSBURG, PA.
FOR

STATE OF OHIO
DEPARTMENT OF HIGHWAYS
DIVISION OF DESIGN AND CONSTRUCTION
BUREAU OF BRIDGES

ABUTMENTS
BRIDGE NO. LAK-2-1424
RELOC. S.R. 2 UNDER NEWELL ST.
LAKE COUNTY
STA. 651 + 99.35

DESIGNED	DRAWN	TRACED	CHECKED	REVIEWED	DATE	REVISED
G.M.P.	C.L.S.	J.P.S.	L.P.	M.C.	1-12-80	