

- A. 1-SERIES OF 3-A1001 @ 7" B.
- B. 5-A1002 @ 7" B.
- C. 3-EC501 @ 18" T.
- D. 1-SERIES OF 3-A1011 @ 7" B.

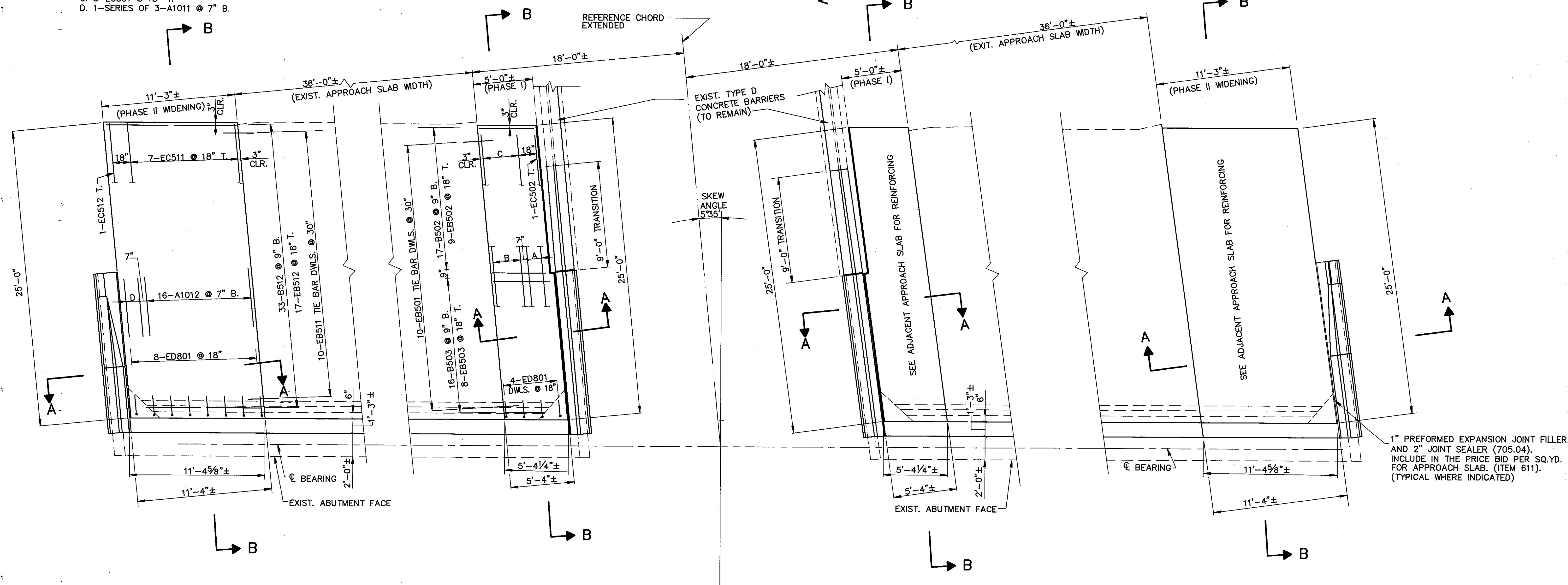

1" PREFORMED EXPANSION JOINT FILLER AND 2" JOINT SEALER (705.04). INCLUDE IN THE PRICE BID PER SQ. YD. FOR APPROACH SLAB. (ITEM 611). (TYPICAL WHERE INDICATED)

APPROACH SLAB WIDENING PLANS

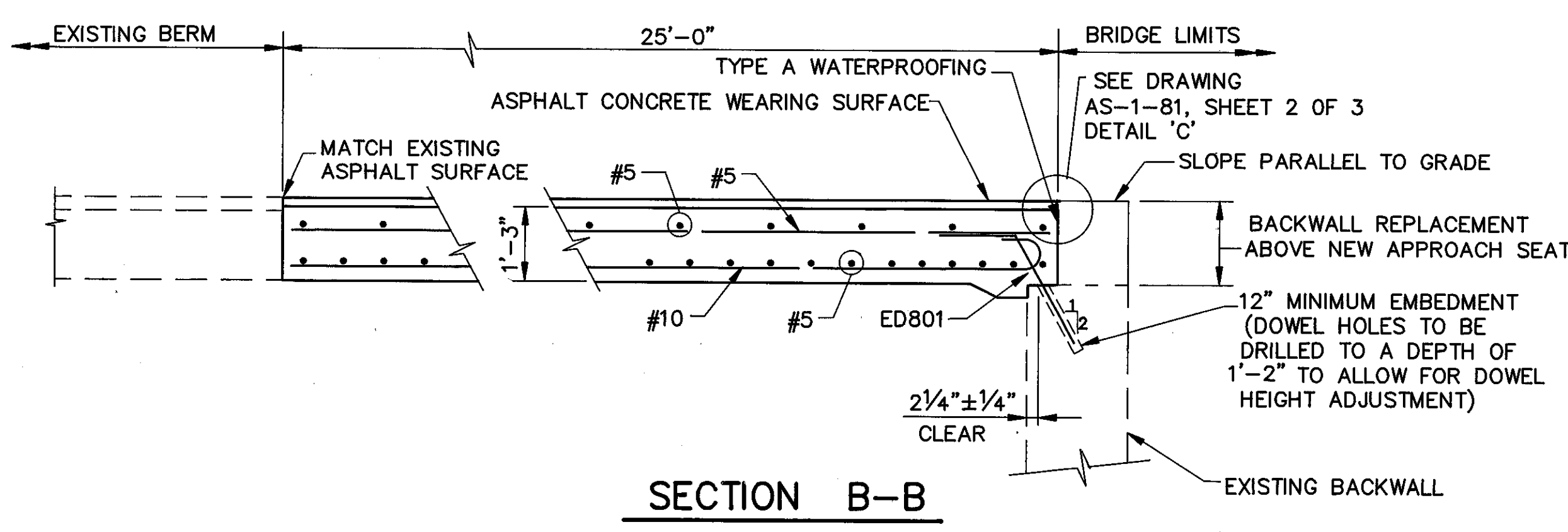

SECTION B-B

NOTES:
 FOR SECTION A-A, SEE SHEET 12/78.
 FOR APPROACH SLAB SEAT WIDENING DETAIL, SEE SHEET 8/78 AND 9/78.
 FOR ADDITIONAL INFORMATION SEE DRAWING AS-1-81 SHEETS 1 & 2 OF 3.
 NOTATION : T. - TOP OF SLAB, B. - BOTTOM OF SLAB, CLR. - CLEAR, EXIST. - EXISTING

COLPETZER-THOMAS, INC.
 AN ENGINEERING GROUP
 WILLOUGHBY • MENTOR • NORTH CANTON • STEUBENVILLE • LORAIN

APPROACH SLAB WIDENING DETAILS
 BRIDGE NO. LAK-2-0180 L & R
 OVER RUSH ROAD
 LAKE COUNTY

DESIGNED	DRAWN	TRACED	CHECKED	REVIEWED DATE	REVISED
J.P.R.	M.T.W.	M.T.W.	R.J.C.	JEA 11/15/88	