

L-1
KEEP LEFT

L-2
LEFT LANE

R-1
KEEP RIGHT

R-2
RIGHT LANE

TYPICAL SIGN

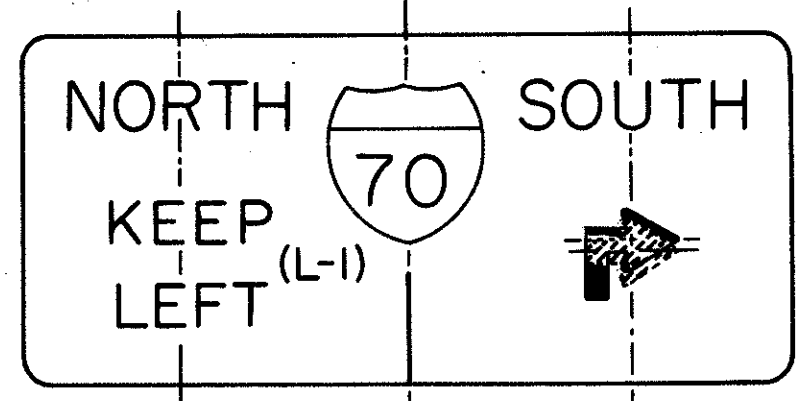

TYPICAL SIGN

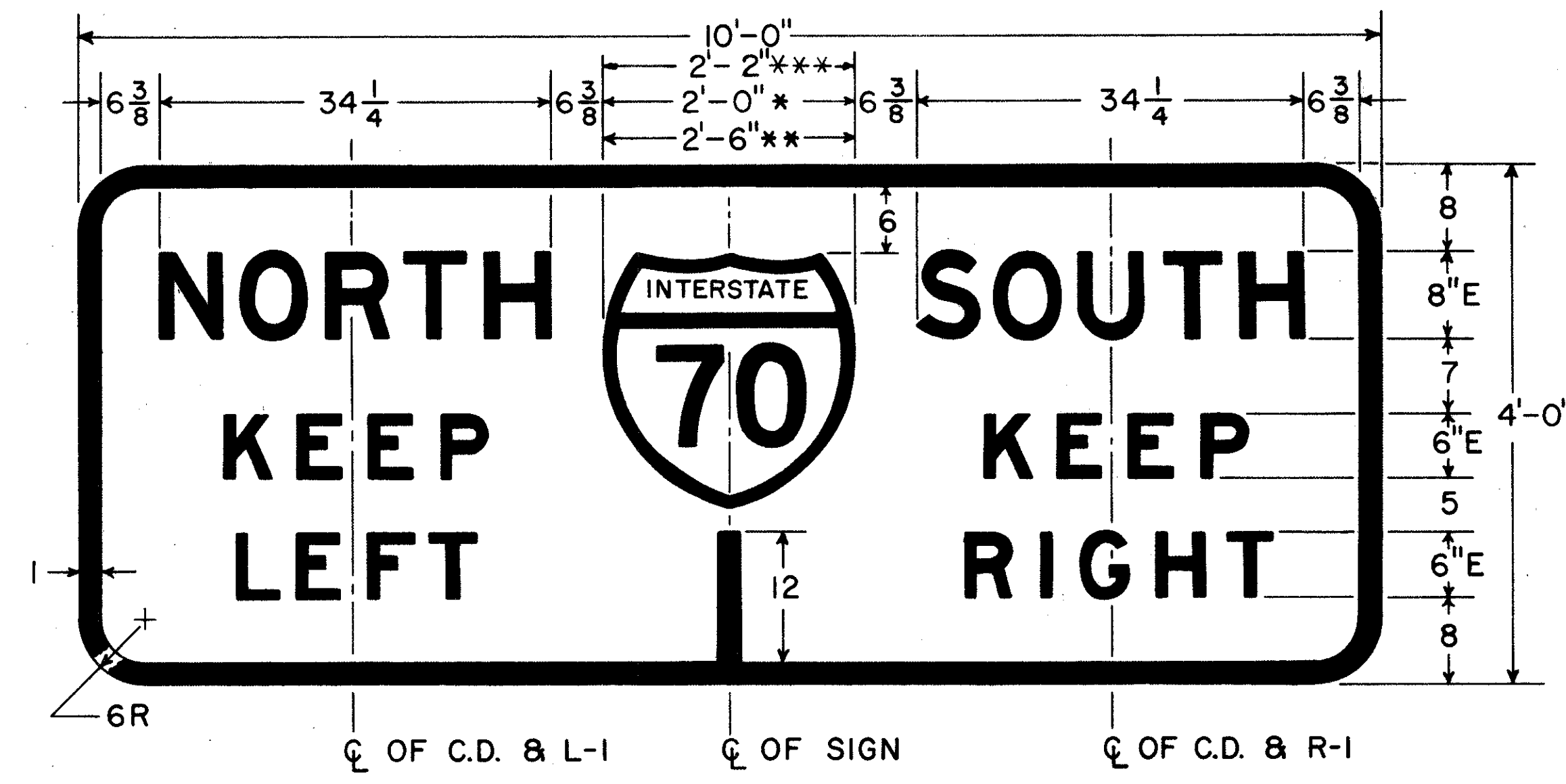
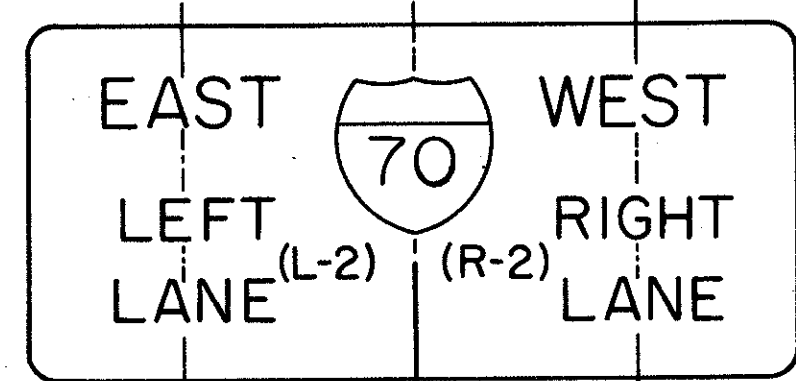

D-3B-24-G

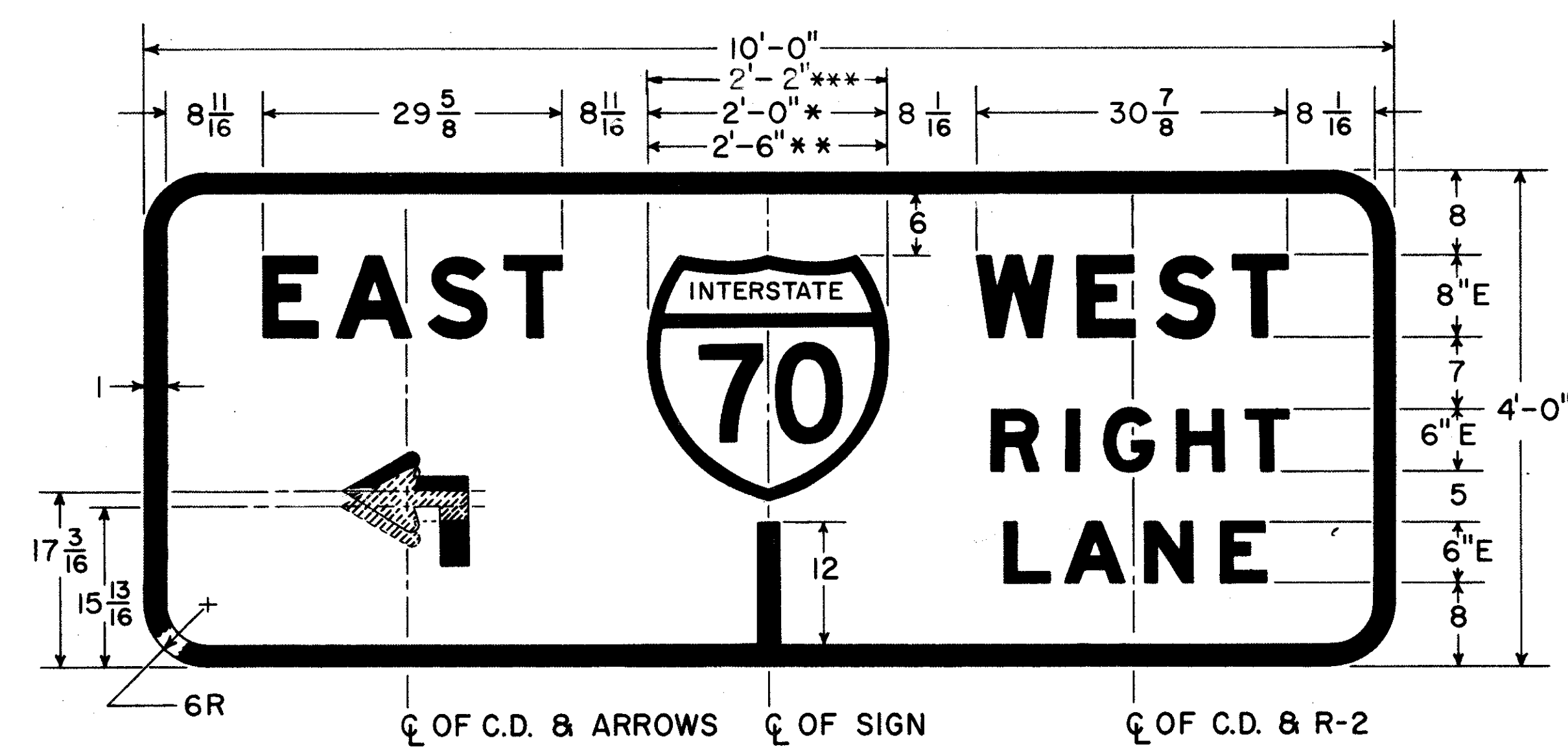

* U.S. MARKER OR OHIO MARKER MAY BE USED IN PLACE OF INTERSTATE MARKER SHOWN.

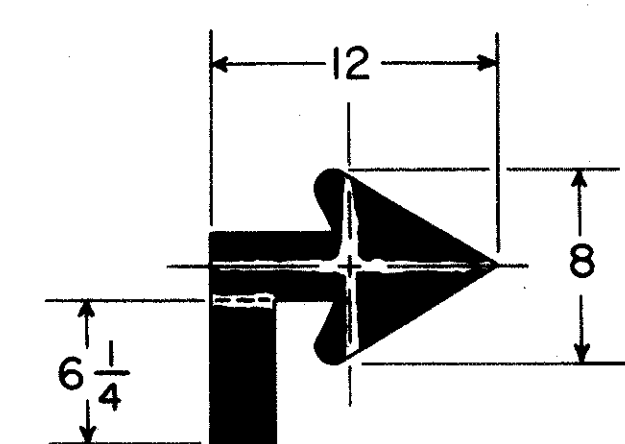

DIMENSIONS FOR 8" x 12" ARROW WITH 6 1/4" EXTENSION USED ON ADVANCE TURN GUIDE SIGNS.

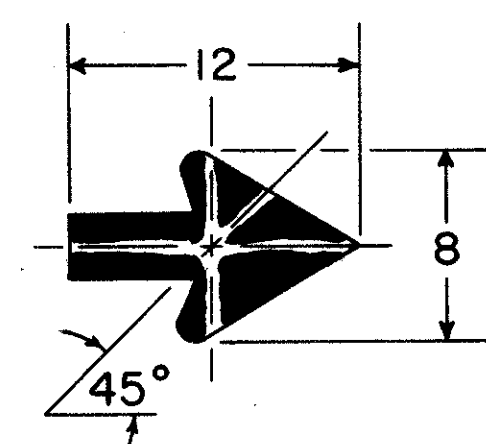

8" x 12" ARROW ROTATED ABOUT C FOR USE IN DIAGONAL AND VERTICAL POSITIONS PLUS THE HORIZONTAL, SHOWN.

INTERSTATE & U.S. 3 DIGIT MARKERS	CARDINAL DIRECTION	OHIO 3 DIGIT MARKER
SPACING LEFT & RIGHT		SPACING LEFT & RIGHT
** 4.87	NORTH	*** 5.87
** 4.88	SOUTH	*** 5.88
** 7.19	EAST	*** 8.19
** 6.56	WEST	*** 7.56

	N	O	R	T	H	TOTAL				
8"E	5.87	1.37	6.12	1.37	5.87	.87	5.50	1.25	6.00	34 1/4
	S	O	U	T	H	TOTAL				
8"E	5.87	.94	6.12	1.37	5.87	1.25	5.50	1.25	6.00	34 1/4
	E	A	S	T	TOTAL					
8"E	5.50	2.00	7.25	1.87	5.87	1.63	5.50	29 5/8		
	W	E	S	T	TOTAL					
8"E	7.50	2.75	5.50	2.12	5.87	1.62	5.50	30 7/8		
	K	E	E	P	TOTAL					
6"E	4.62	1.87	4.25	2.12	4.25	2.12	4.75	24		
	L	A	N	E	TOTAL					
6"E	4.25	1.25	5.25	2.00	4.62	2.75	4.25	24 3/8		
	L	E	F	T	TOTAL					
6"E	4.25	1.87	4.25	2.12	4.25	1.12	4.25	22 1/8		
	R	I	G	H	T	TOTAL				
6"E	4.75	2.12	1.25	2.12	4.75	2.12	4.62	1.87	4.25	27 7/8

NOTE: ALL DIMENSIONS ARE IN INCHES UNLESS OTHERWISE SHOWN.

BUREAU OF TRAFFIC
OHIO DEPARTMENT OF HIGHWAYS

TRAFFIC SIGNS

DATE: 4-28-65
2-14-66

APPROVED *Paul J. Taylor*
ENGINEER OF TRAFFIC