

Lot Split Survey
 Joseph & Patricia Luck
 29402 Eddy Road
 Willoughby Hills, Ohio
 Part of Original Willoughby Township
 Lot No. in Tract No. 3
 File No. 14-1087
 Field Book 137, Page 42
 Drawing Name Gazdak.zak
 Bearings are based on the West line of Tract No. 3
 being South 00 degrees 14' 21" East as shown in Volume
 2 of Maps, Page 35 Lake County Plats

SCHADE SURVEYING COMPANY
 4043 Erie Street Willoughby, Ohio
 Phone (440) 951-6454

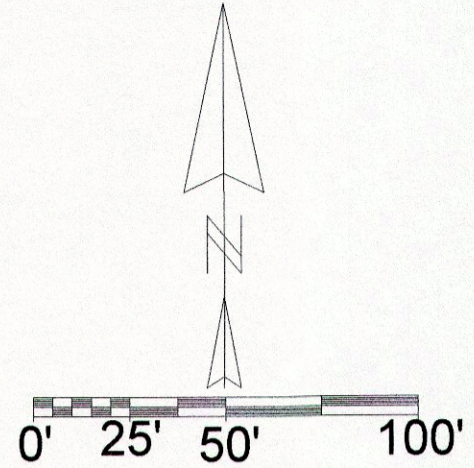

STATE OF OHIO
 WILLARD F. SCHADE, JR.
 6008
 REGISTERED SURVEYOR
Willard F. Schade, Jr.
 3-25-14