

SECTION A-A

ELEVATION

FOOTING ANCHOR

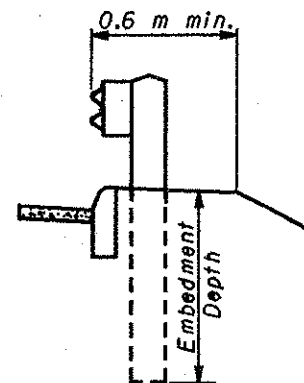

DETAIL A

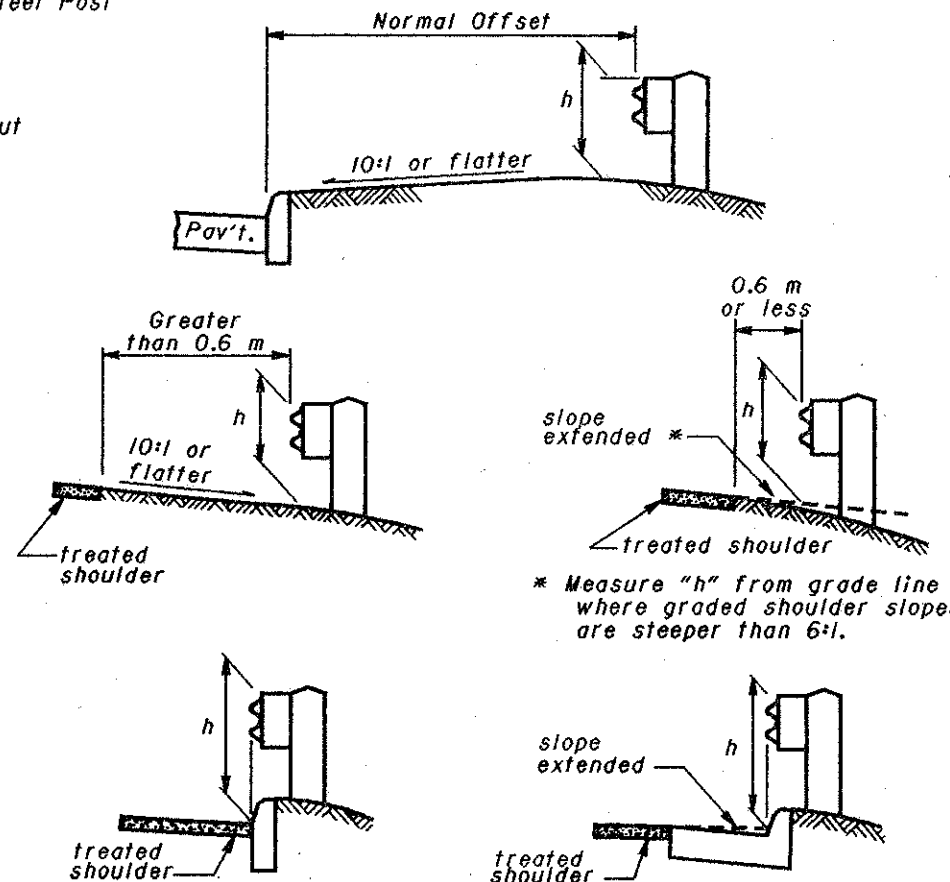

h - Standard height (Tolerance ± 25 mm)

MEASURING GUARDRAIL HEIGHT

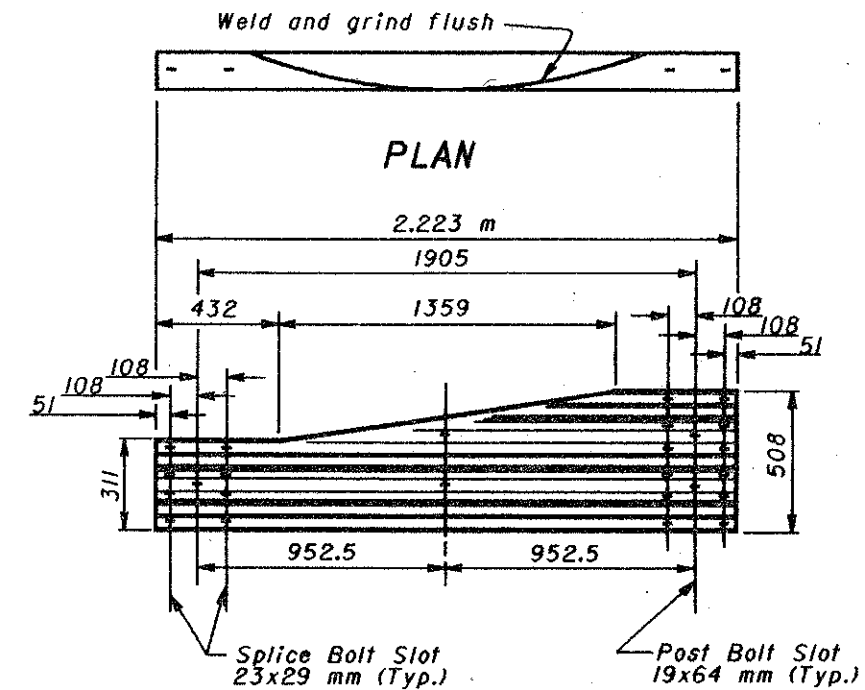

ELEVATION

TYPE 2
TRANSITION SECTION *
(W-Beam to Thrie-Beam)

* For details of Type 1 Transition Section, refer to AASHTO M 180, Figure 4.

NOTES

BEAM RAIL ELEMENTS: Elements shall be 3.81 m effective length, unless otherwise specified, with 19x64 mm post bolt slots on 1.905 m centers regardless of post spacing. Field punching or drilling of bolt holes or slots for irregularly spaced posts shall be according to CMS 606.05.

BEAM RAIL SPLICE between two rail elements or between a rail and terminal connector shall be lapped in the direction of traffic. The buffer or flared end sections shall lap on the traffic face. A 305 mm length of beam rail (Back-up Plate), with a 19 mm diameter bolt hole or a 19x64 mm slot, shall be provided at steel posts not having a rail splice.

EMBEDMENT DEPTH: Where less than 0.6 m of graded shoulder width (10:1 or flatter) exists, measured from the face of the guardrail (see Detail "A"), longer posts shall be used so that a minimum of 1.65 m embedment depth is provided. Payment for the longer posts will be made at the unit price bid per Each, Item 606 - Guardrail Post, 2.75 m.

PROTECTIVE COATING: In lieu of the requirements of CMS 710.06, expansion shields, anchors and insert anchor assemblies installed (embedded) in concrete shall be coated in accordance with ASTM A 153 or be of stainless steel. Any bolts screwed into these embedded devices shall meet CMS 710.06.

SPECIAL POST MOUNTINGS:

Posts located over a drainage inlet or structure shall be encased or anchored per the details shown on Standard Construction Drawing GR-2.2M.

Posts located over a footing with a cover of less than 0.75 m shall be installed with a footing anchor as detailed hereon. (A plate, as detailed on Section B-B of Standard Construction Drawing GR-2.2M, may be used as an alternate attachment method.) Where the cover is between 0.75 m and 1.04 m, the footing anchor may be omitted and the post encased instead with 100 mm (min.) of concrete.

Posts located over a culvert with less than 1.3 m of cover shall not be driven, but shall be set in drilled or dug holes. Where the available post embedment depth is less than 1.04 m, the post shall be encased with 100 mm (min.) of concrete.

All costs associated with special post mountings shall be included in the unit price bid for 606 Guardrail of the type specified in the plans.

ANCHORS: Holes and grouting shall comply with CMS 510. Either cement or nonshrink, nonmetallic grout may be used.

Expansion shield anchors conforming to CMS 712.01 may be substituted except where concrete deterioration has occurred, as determined by the Engineer. The same bolt diameter specified shall be required. Where self-drilling anchors are used, the holes shall be drilled with the expansion shield (not by a drill bit) and the shield installed flush with the concrete surface.

All dimensions are in millimeters unless otherwise noted.



This Drawing Replaces GR-1.2.

OFFICE OF ROADWAY ENGINEERING OHIO DEPARTMENT OF TRANSPORTATION	
GUARDRAIL DETAILS	DATE 1-3-96
	STANDARD CONSTRUCTION DRAWING GR-1.2M
APPROVED <u>D.K. Hulman, P.E.</u> ADMINISTRATOR	