

☐ - THIS DIMENSION IS THE SUM OF (2xSTEEL RETAINER WIDTH+DIM. "A").

**SECTION Y-Y**

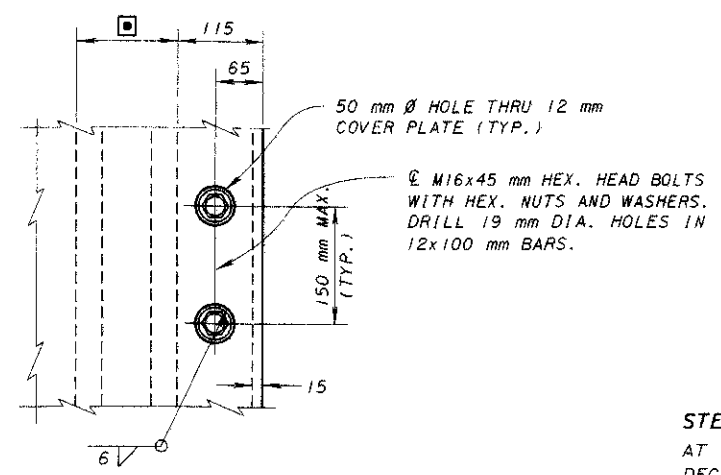

**VIEW E-E**

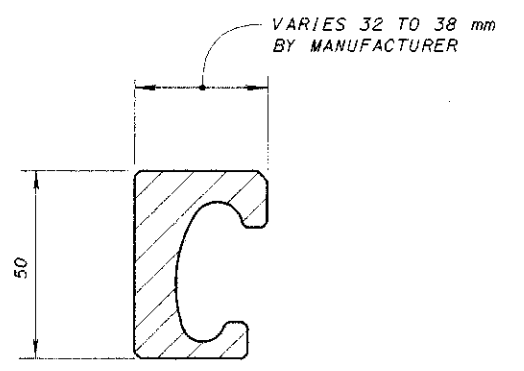

**RETAINER DETAIL**

**STEEL RETAINER REQUIREMENTS:**

AT JOINT UPTURNS, ESPECIALLY ON SKEWED BRIDGE DECKS, THE USE OF SPLIT RETAINERS MAY BE NECESSARY TO ENSURE GOOD SEAL GLAND INSTALLATION. WHEN THE SPLIT RETAINER IS USED, THE DESIGN SHALL BE SUBMITTED TO THE DIRECTOR FOR APPROVAL.

THE PROPOSED STEEL RETAINER SHALL CONFORM TO THE DIMENSIONS SHOWN ABOVE. THE RETAINERS SHALL BE PRODUCED AS A SOLID SHAPE EXTRUSION, A HOT ROLLED SOLID SHAPE OR SOLID SHAPE MACHINED FROM A SOLID BAR OF STEEL. STEEL RETAINERS MANUFACTURED BY THE BENDING OF A PLATE OR WELDING OF PIECES TOGETHER ARE NOT ACCEPTABLE. THE INTERNAL DIMENSIONS OF THE STEEL RETAINER SHALL MATCH THE MANUFACTURER'S REQUIREMENTS FOR POSITIVE ANCHORAGE FOR THE GLAND.

ANY DEFECTS IN THE STEEL RETAINER OR THE ACTUAL EXPANSION JOINT THAT COULD CAUSE DAMAGE TO THE GLAND SHALL BE CORRECTED BEFORE THE GLAND IS INSTALLED.

**TEMPORARY JOINT ARMOR SUPPORTS**

TEMPORARY SUPPORTS SHALL BE INSTALLED THAT ARE CAPABLE OF SUPPORTING SHIPPING AND ERECTION FORCES WITHOUT DAMAGE TO THE EXPANSION DEVICE. FABRICATOR DESIGNED AND INSTALLED TEMPORARY SUPPORTS SHALL BE CAPABLE OF ADJUSTMENT FOR SETTING THE EXPANSION DEVICE IN THE FIELD AND SHALL BE INSTALLED AT THE FABRICATION SHOP AFTER FABRICATION AND COATING IS COMPLETED.

**CONSTRUCTION PROCEDURE**

1. ABUTMENT BACKWALL CONCRETE SHALL NOT BE PLACED UNTIL AFTER SUPERSTRUCTURE CONCRETE IN THE SPAN ADJACENT TO THE ABUTMENT HAS BEEN PLACED.
2. PLACE BACKWALL CONCRETE DURING STABLE OR RISING AMBIENT TEMPERATURES AND CONCLUDE PLACEMENT AT OR IMMEDIATELY BEFORE THE DAY'S PEAK AMBIENT TEMPERATURE.
3. NOT MORE THAN FOUR HOURS PRIOR TO THE DAY'S PEAK AMBIENT TEMPERATURE, SET ABUTMENT EXPANSION JOINT WIDTH TO DIMENSION "A". SEE DIMENSION "A" TABLE ON PROJECT PLANS.
4. LOOSEN ANY TEMPORARY JOINT ARMOR BOLTS AFTER INITIAL SET OF CONCRETE, PREFERABLY NOT LATER THAN TWO HOURS AFTER CONCLUSION OF CONCRETE PLACEMENT.

DESIGN AGENCY: BUREAU OF BRIDGES AND STRUCTURAL DESIGN  
 STATE OF OHIO DEPARTMENT OF TRANSPORTATION  
 REVIEWED: WTL/LMW  
 CHECKED: JS  
 DESIGNED: AJM  
 DRAWN: AJM  
 REVISIONS: 2-18-97  
 STANDARD: STRIP SEAL EXPANSION JOINTS FOR STEEL STRINGER STRUCTURES  
 DATE: 3-20-95  
 ENGINEER OF BRIDGES: *Richard L. Enger*