

**PART PLAN AT ABUTMENT
FOR BRIDGES WITH SIDEWALK
PARAPET RAILING**

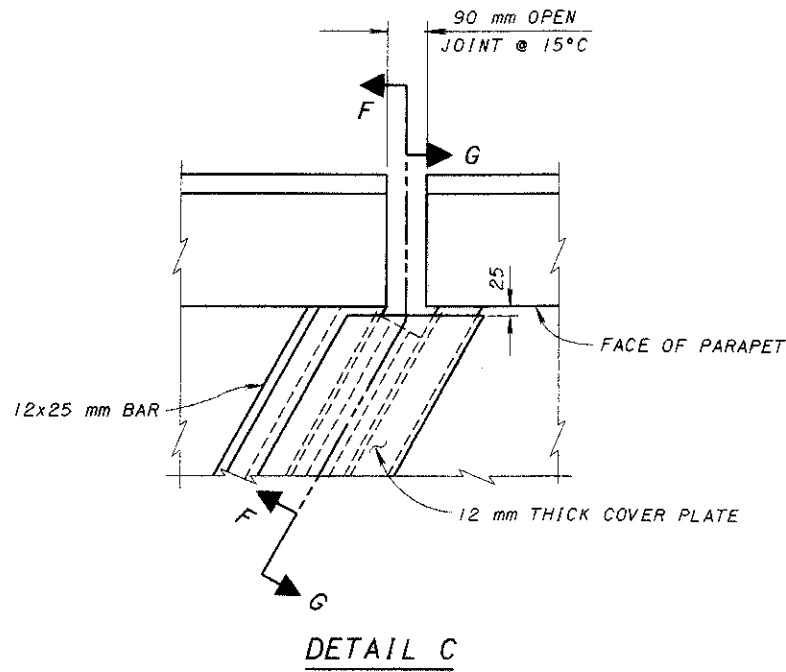

DETAIL C

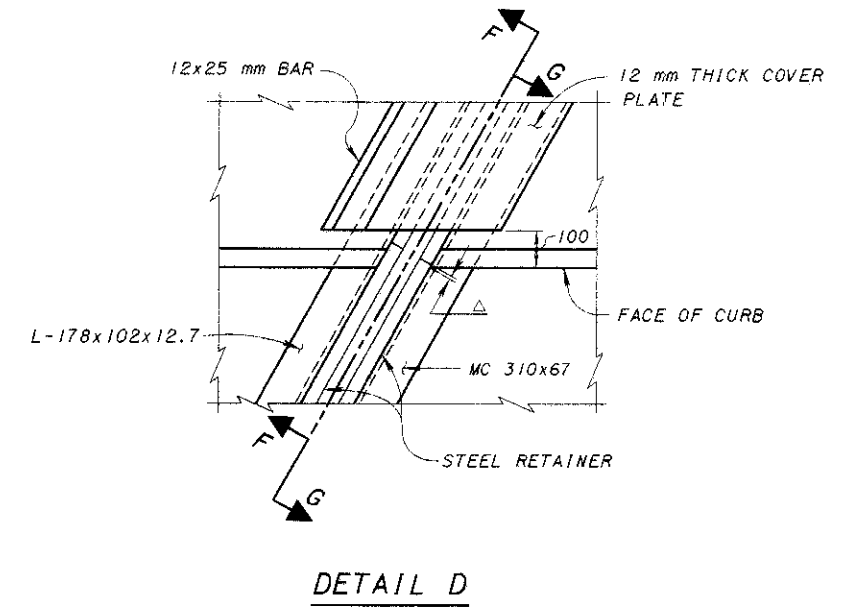

DETAIL D

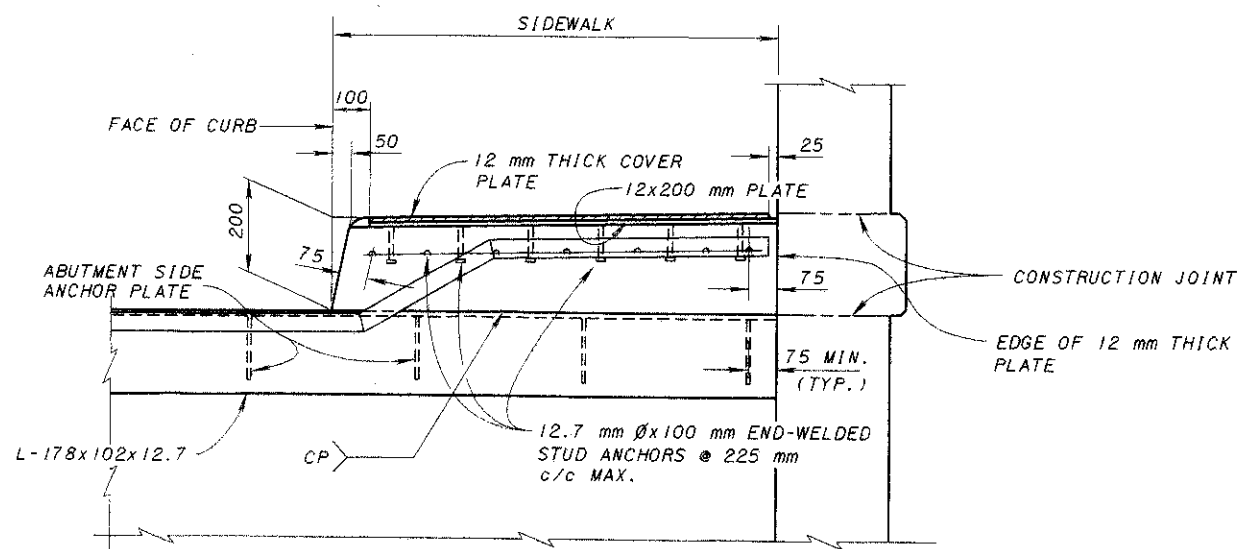

SECTION F-F

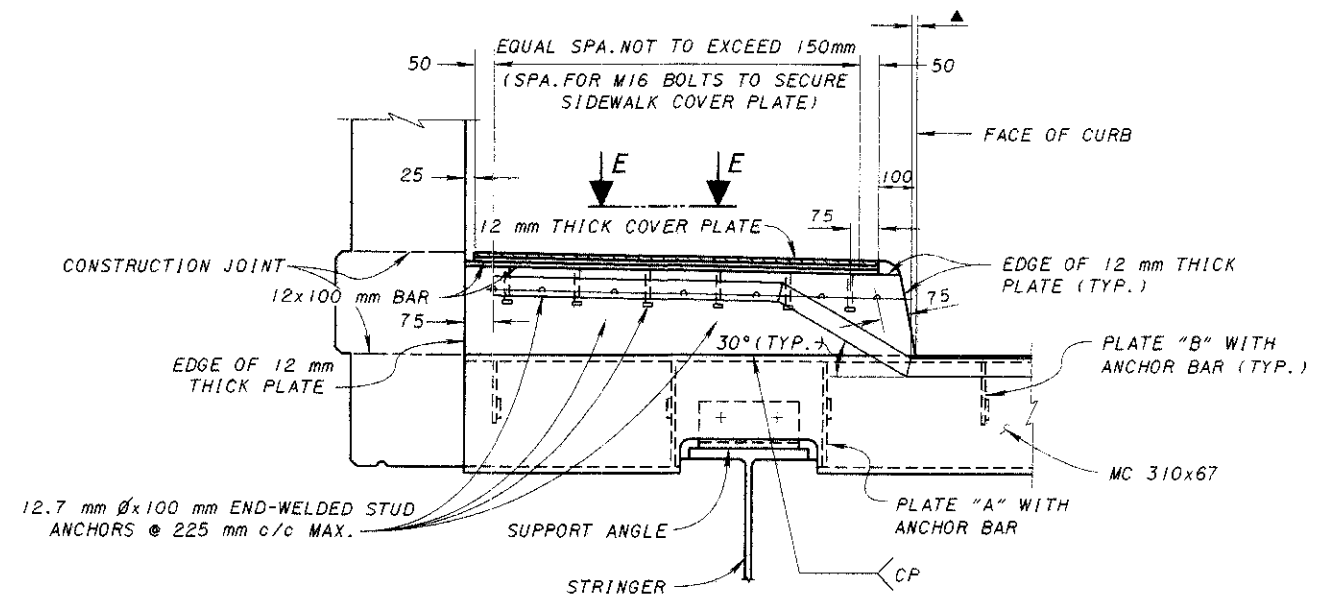

SECTION G-G

▲ - 0 MIN. TO 13 mm MAX. AT BREAKPOINT IN RETAINER FOR SQUARE BRIDGES. ON SKEWED BRIDGES THIS DIMENSION WILL ONLY APPLY TO THE SIDE OF JOINT ASSEMBLY WHICH IS NEAREST TO THE CURB LINE (SEE DETAIL "D" ABOVE).

NOTES:
FOR VIEW E-E SEE SHEET 4/5.
FOR SECTION X-X SEE SHEET 2/5.
FOR SECTION Y-Y SEE SHEET 4/5.

DESIGN AGENCY: BUREAU OF BRIDGES AND STRUCTURAL DESIGN
 STATE OF OHIO DEPARTMENT OF TRANSPORTATION
 3-20-95 DATE
 ENGINEER OF BRIDGES
 REVIEWED: WT/L/LMW
 CHECKED: JS
 DESIGNED: AJM
 DRAWN: AJM
 EXJ-4-87N
 REVISIONS: 2-18-97
 STANDARD STRIP SEAL EXPANSION JOINTS FOR STEEL STRINGER STRUCTURES
 3 5