

NOTES

1. BASE PLATE WELD SIZE SHALL BE EQUAL TO THE BEAM FLANGE AND WEB THICKNESS RESPECTIVELY, BUT NO LESS THAN 1/4" INCH IN EITHER INSTANCE.
2. BEVELED WASHERS SHALL BE USED WITH THE S4 X 7.7 BEAM AND SHALL BE MALLEABLE IRON CONFORMING WITH ASTM A47 GRADE 35018.
3. FUSE AND HINGE PLATE CONNECTIONS SHALL BE TIGHTENED IN THE SHOP FOLLOWING A METHOD APPROVED BY THE ENGINEER TO PRODUCE THE MINIMUM BOLT PRELOAD SPECIFIED.
4. THE FOLLOWING PROCEDURE SHALL BE USED IN ASSEMBLING THE BREAKAWAY BASE PLATE:
AFTER ALL BOLTS, WASHERS, STANDARD NUTS AND BOLT RETAINER PLATE ARE IN PLACE, TIGHTEN ALL STANDARD NUTS SNUGLY WITH A 12" WRENCH. LOOSEN EACH BOLT IN TURN AND RETIGHTEN IN A SYSTEMATIC MANNER TO THE SPECIFIED MAXIMUM TORQUE. WRENCHES SHALL BE CALIBRATED AT LEAST ONCE EACH WORKING DAY FOR EACH BOLT DIAMETER BEING TORQUED. BURR THREADS AT JUNCTION WITH NUT USING A CENTER PUNCH.
5. IN LIEU OF THE STANDARD NUTS AND PROCEDURES OUTLINED IN 3 AND 4 ABOVE, THE SUPPORTS MAY BE ASSEMBLED USING TORQUE LIMITING NUTS. EACH NUT SHALL BE TIGHTENED WITH SUFFICIENT TORQUE APPLIED UNTIL THE UPPER WRENCHING SURFACE HAS SHEARED AWAY FROM THE STRUCTURAL BODY OF THE NUT. FUSE AND HINGE PLATES SHALL BE SHOP ASSEMBLED FOLLOWING THIS PROCEDURE. THE NUTS USED SHALL BE AS MANUFACTURED BY HI-SHEAR CORP., TORRANCE CALIFORNIA; VOI SHAN INDUSTRIES - CULVER CITY, CALIFORNIA; STANDARD PRESSED STEEL - JENKINTOWN, PENNSYLVANIA OR APPROVED EQUAL.
THE TORQUE LIMITING NUT PART NUMBER CHL-14 SHALL BE USED FOR THE BASE PLATE, CHL-II FOR THE FUSE AND HINGE PLATES.
6. FOR BEAMS SUBJECT TO IMPACT FROM OPPOSITE DIRECTIONS (SUCH AS IN FREEWAY MEDIANS) PROVIDE FUSE PLATES ON BOTH SIDES.
7. NOTCHES SHOWN FOR INSTALLATION TO THE RIGHT OF TRAFFIC. FOR INSTALLATIONS TO THE LEFT OF TRAFFIC, FABRICATE WITH SKEWED EDGE OF NOTCHES REVERSED FROM THAT SHOWN.
8. DIMENSIONS SHOWN FOR ALTERNATE DESIGNS ARE APPROXIMATE. SPECIFIC DIMENSIONS FOR ALTERNATE DESIGNS REQUIRE PREQUALIFICATION. AN APPROVED LIST OF SUPPLIERS IS MAINTAINED BY O.D.O.T. PAYMENT FOR ALTERNATE DESIGNS WILL BE BASED ON THE PLAN QUANTITIES FOR EMBEDDED BEAMS.

ALL ITEMS SHALL CONFORM TO C & M SPECIFICATIONS 630 AND 730, UNLESS OTHERWISE SPECIFIED.

BUREAU OF DESIGN SERVICES DIVISION OF HIGHWAYS OHIO DEPARTMENT OF TRANSPORTATION		DATE
TRAFFIC CONTROL		8/19/79
STRUCTURAL BEAM		3/26/79
SIGN SUPPORTS		12/23/81
STANDARD CONSTRUCTION DRAWING		8/29/84
TC-41.10		
APPROVED: <i>[Signature]</i> Engineer of Design Services		

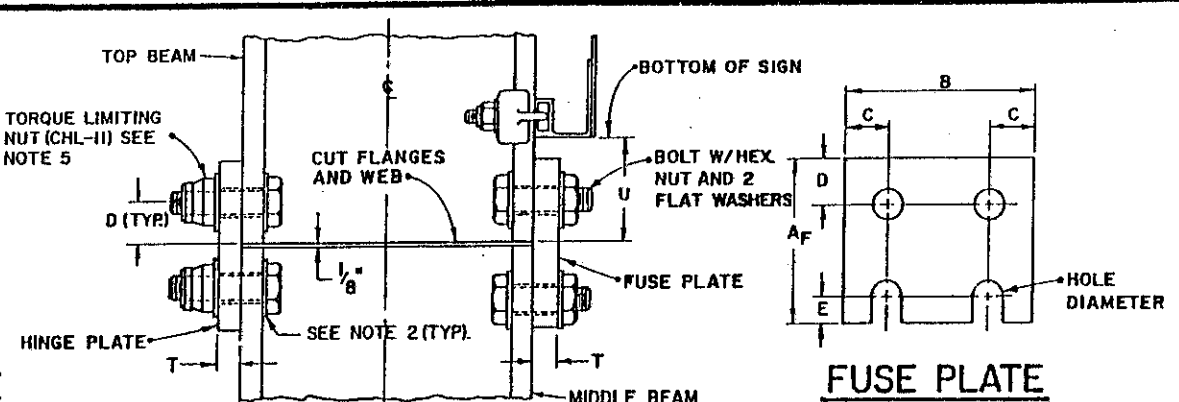
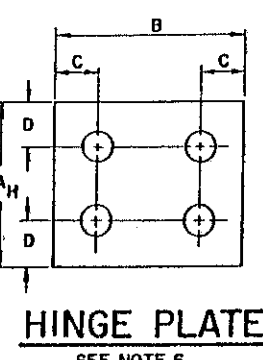
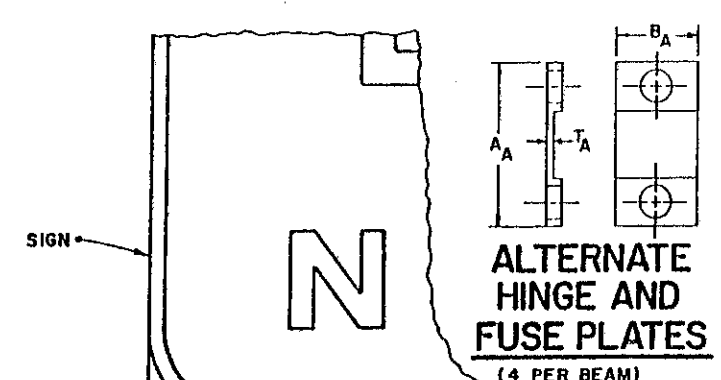

HINGE AND FUSE PLATE DIMENSIONS, INCHES												ALTERNATE DESIGN SEE NOTE 8				
BEAM TYPE	BEAM SIZE	A _H	A _F	B	C	D	E	T	U	HOLE DIA.	BOLT SIZE	MIN. PRELOAD (lbs)	A _A	B _A	BOLT SIZE	T _A
S4 X 7.7	4 X 2 5/8	4 1/8	3 5/8	2 5/8	9/16	1	1/2	3/16	2 1/2	9/16	1/2	10,000	3 3/4	1	1/2	.071
W6 X 9	5 7/8 X 4	4 1/8	3 5/8	4	7/8	1	1/2	3/16	2 1/2	9/16	1/2	10,000	3 3/4	1	1/2	.071
W10 X 12	9 7/8 X 4	6 1/8	5 3/8	4	7/8	1 1/2	3/4	3/16	3 1/2	13/16	3/4	25,000	4 3/4	1	1/2	.071
W8 X 18	8 5/8 X 5 1/4	7 1/8	6 1/4	5 1/4	1 1/4	1 3/4	7/8	1/4	4	15/16	7/8	38,000	4 3/4	1 1/2	3/4	.113
W10 X 22	10 1/8 X 5 3/4	8 1/8	7 1/8	5 3/4	1 1/2	2	1	5/16	4 1/2	1 1/16	1	46,000	4 3/4	1 1/2	3/4	.113
W12 X 30	12 3/8 X 6 1/2	8 1/8	7 1/8	6 1/2	1 1/2	2	1	5/16	4 1/2	1 1/16	1	46,000	4 3/4	1 1/2	3/4	.113

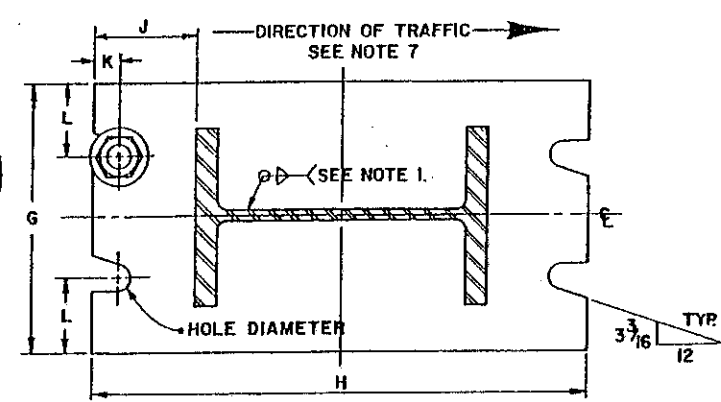
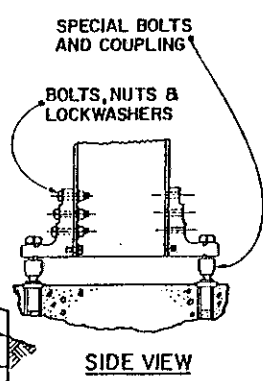
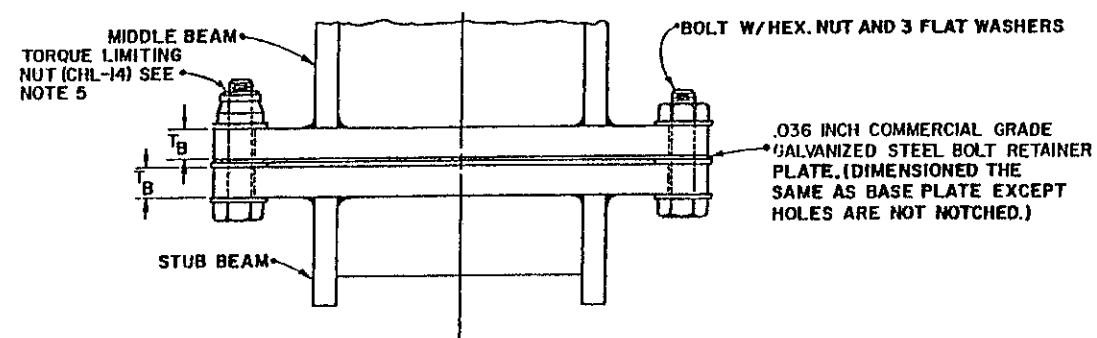

FOUNDATIONS			BASE PLATE DIMENSIONS, INCHES										ALTERNATE DESIGN SEE NOTE 8		
BEAM TYPE	BEAM SIZE	CONCRETE cu.yd/ea.	DIMENSIONS							HOLE DIA.	BOLT SIZE	MAX. TORQUE in./lbs	G _A	H _A	BOLT SIZE
			G	H	J	K	L	T _B							
S4 X 7.7	4 X 2 5/8	.27	4	8	2	1/2	1	3/4	9/16	1/2	200	4 1/4	7 1/16	1/2	
W6 X 9	5 7/8 X 4	.33	5 1/2	10	2 1/16	1/2	1	3/4	9/16	1/2	200	4 1/4	9 9/16	1/2	
W10 X 12	9 7/8 X 4	1.10	8	14 1/2	2 5/16	3/4	1 1/2	3/4	13/16	3/4	750	4 1/4	13 5/8	1/2	
W8 X 18	8 5/8 X 5 1/4	1.10	8	14 1/2	3 1/4	3/4	1 1/2	1	13/16	3/4	750	3	16 1/4	1/2	
W10 X 22	10 1/8 X 5 3/4	1.23	8	14 1/2	2 5/16	15/16	2	1	1 1/16	1	1325	4	18 5/16	5/8	
W12 X 30	12 3/8 X 6 1/2	1.50	10	17	2 7/16	15/16	2	1 1/4	1 1/16	1	1325	4	20 7/16	5/8	

