

Note:
Monuments to be placed by Contractor.

DETAIL OF CENTERLINE REFERENCE MONUMENTS

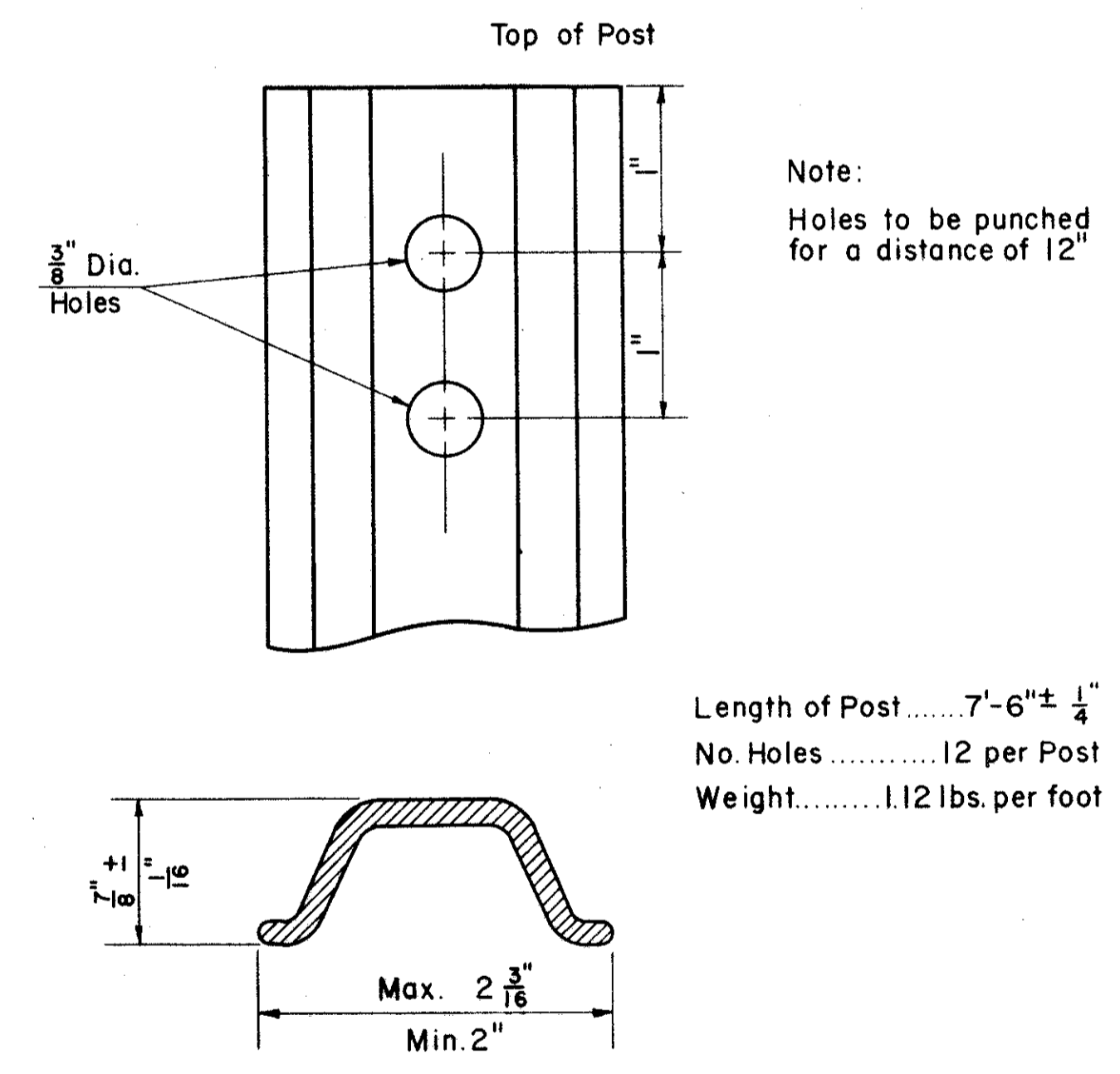

SECTION VIEW

DETAIL OF STEEL DRIVE POST FOR DELINEATOR

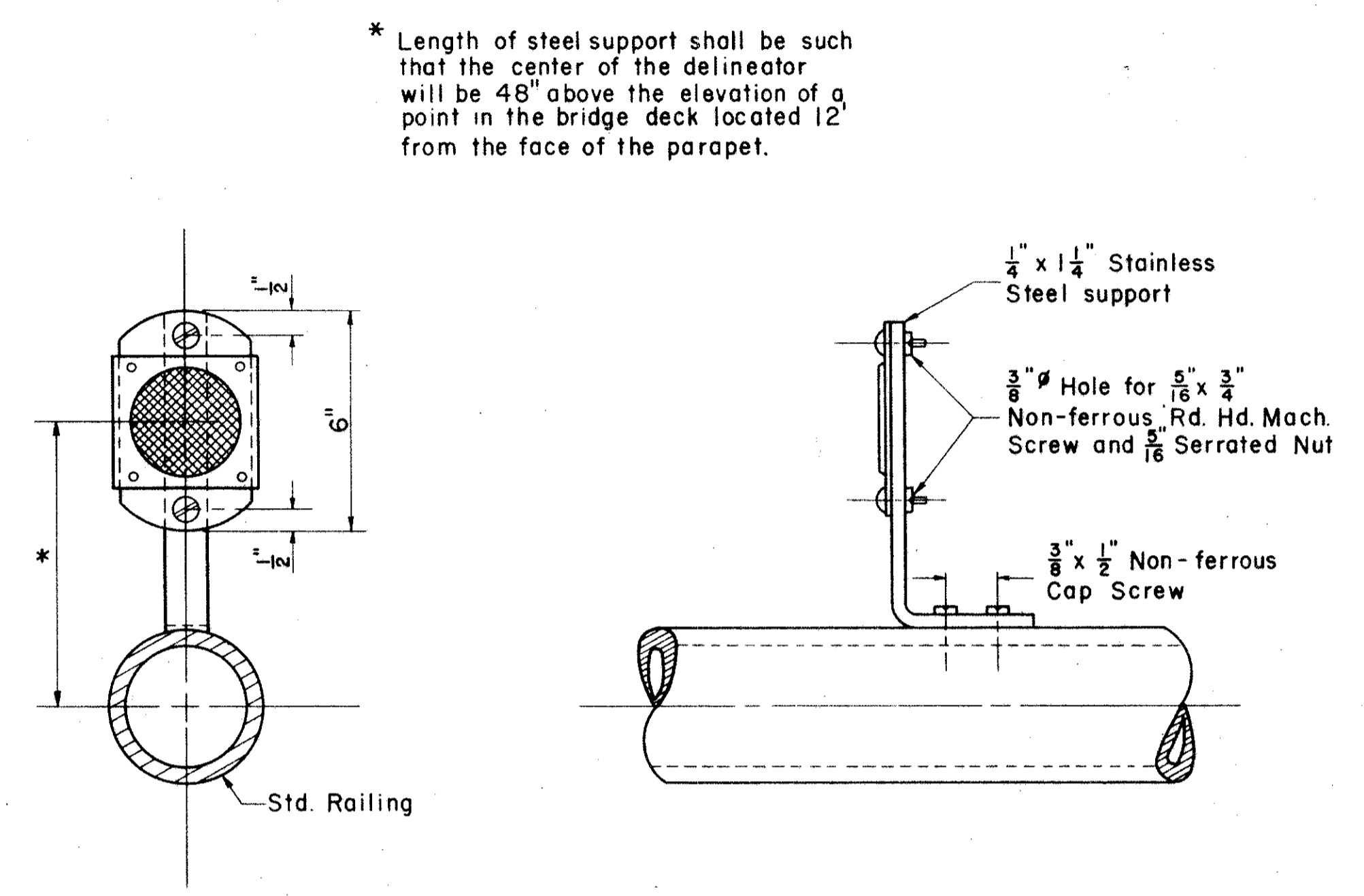

DELINEATOR AND BRIDGE RAIL BRACKET