

CATCH BASIN No. 5

NOTES

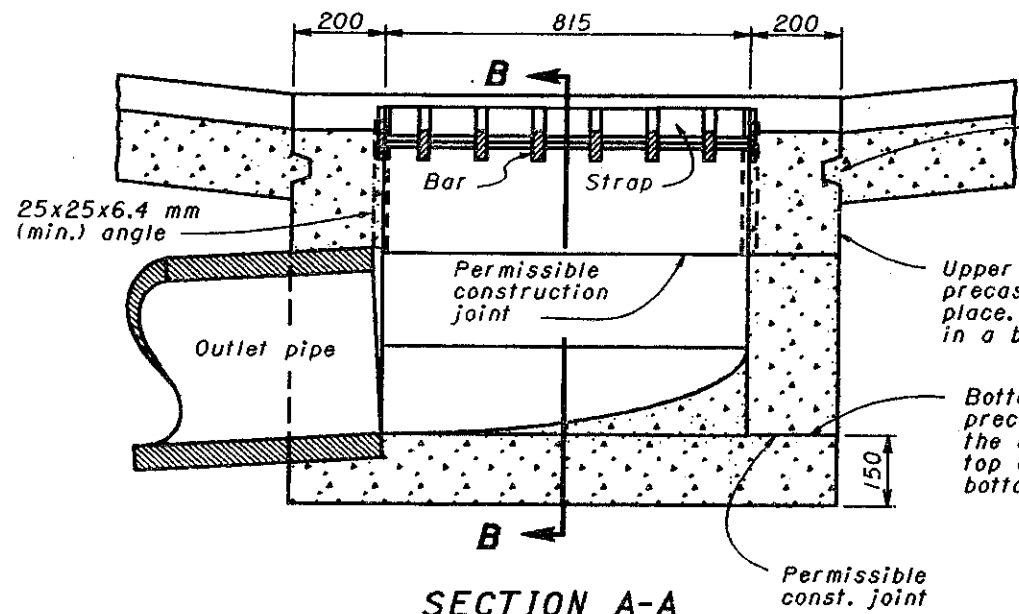

SECTION A-A

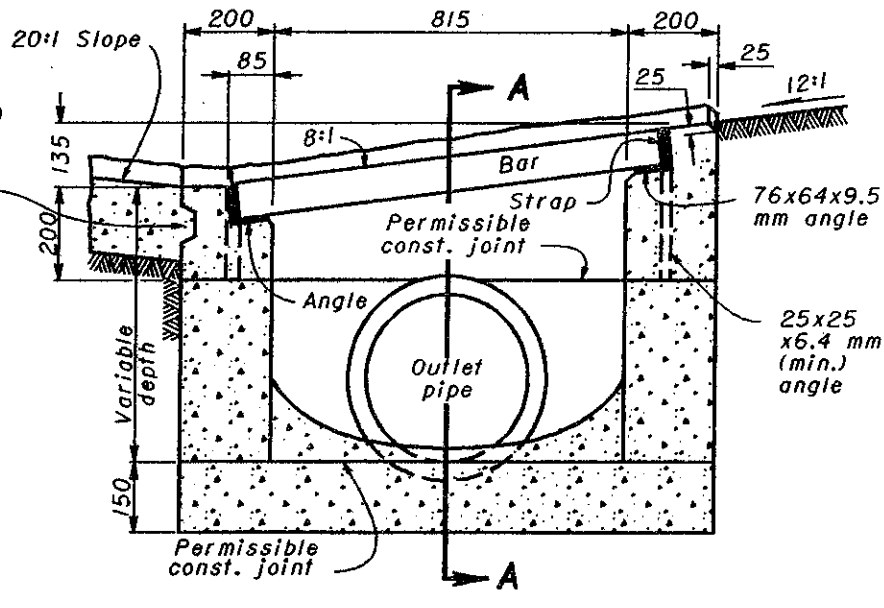

SECTION B-B

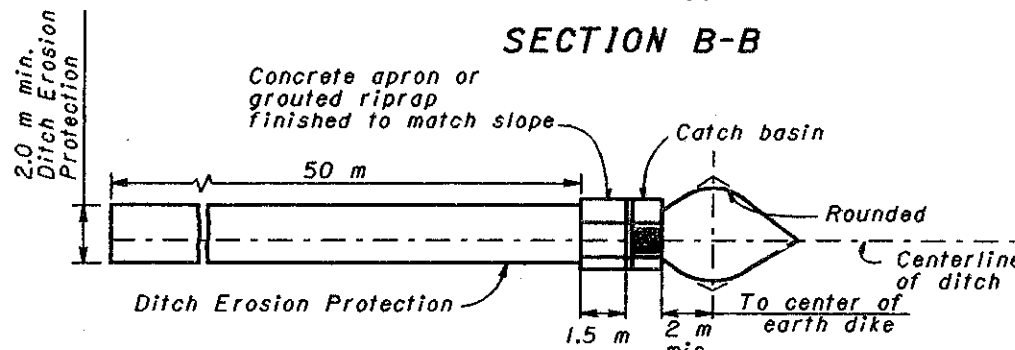
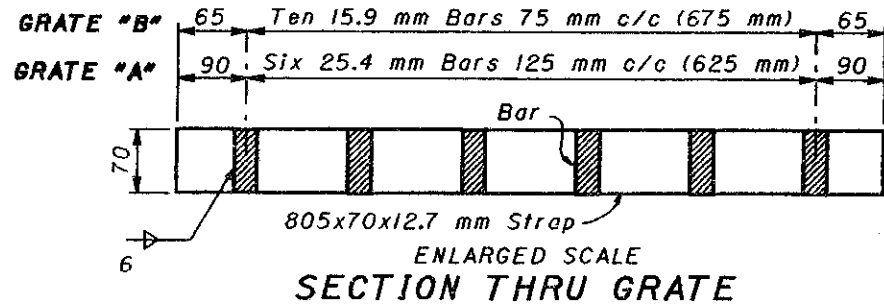

PLAN OF ROADSIDE DITCH GRADING AT CATCH BASIN

- GRATE AND FRAME:** Shall be of structural steel in accordance with CMS 711.01 and 513. The design shall be essentially the same and equally as strong as the one shown hereon.
- GRATE:** Shall be depressed 75 mm below the upstream end of the concrete apron at the centerline of the ditch. Unless Grate "B" is specifically required by the plans, Grate "A" shall be furnished and installed.
- WALLS:** Brick or cast-in-place walls shall have a nominal thickness of 200 mm from the bottom slab to the upper box. Precast walls shall have a minimum thickness of 150 mm and be reinforced sufficiently to permit shipping and handling without damage.
- STEPS:** Steps meeting the requirements of Std. Constr. Dwg. MH-1.1M shall be provided where the depth exceeds 1.8 m.
- BASINS OVER 3.5 m IN DEPTH:** Shall be precast or cast-in-place concrete; reinforced with #15M bars on 300 mm centers both vertically and horizontally with 50 mm clearance from inside wall face.
- LOCATION AND ELEVATION:** When given on the plans, the location is the center of the grate. The elevation is the lowest point on the grate.
- OPENINGS:** Pipe openings shall be the outside diameter of the pipe being supplied plus 50 mm when prefabricated or field cut. The interstitial space shall be filled with grout per CMS 601.
- CONCRETE APRONS:** Aprons are to be constructed in such a manner that the outside edges are at equal elevation.
- DITCH PROTECTION:** Provide a 50 m length of ditch erosion protection as shown. Installation and payment for ditch erosion protection shall comply with CMS 670.
- BASINS IN SAG:** When in a sag, omit the earth dike and longitudinal slope of the grate, and provide concrete and ditch protection on each side of the basin.
- COST:** The concrete apron or grouted riprap and dike shall be considered incidental to Item 604, Catch Basins. However, the apron is not required when Item 604, Catch Basins, Without Apron is specified.

CONSTRUCTION INFORMATION	
Typical mass of grate	- 84 kg
Typical mass of frame	- 27 kg

All dimensions are in millimeters unless otherwise noted.



This Drawing Replaces CB-5.

BUREAU OF LOCATION AND DESIGN
OHIO DEPARTMENT OF TRANSPORTATION

CATCH BASIN
No. 5

DATE
7-12-95

STANDARD CONSTRUCTION DRAWING
CB-3.2M

APPROVED: *W.K. Hillman*
ENGR., L & D

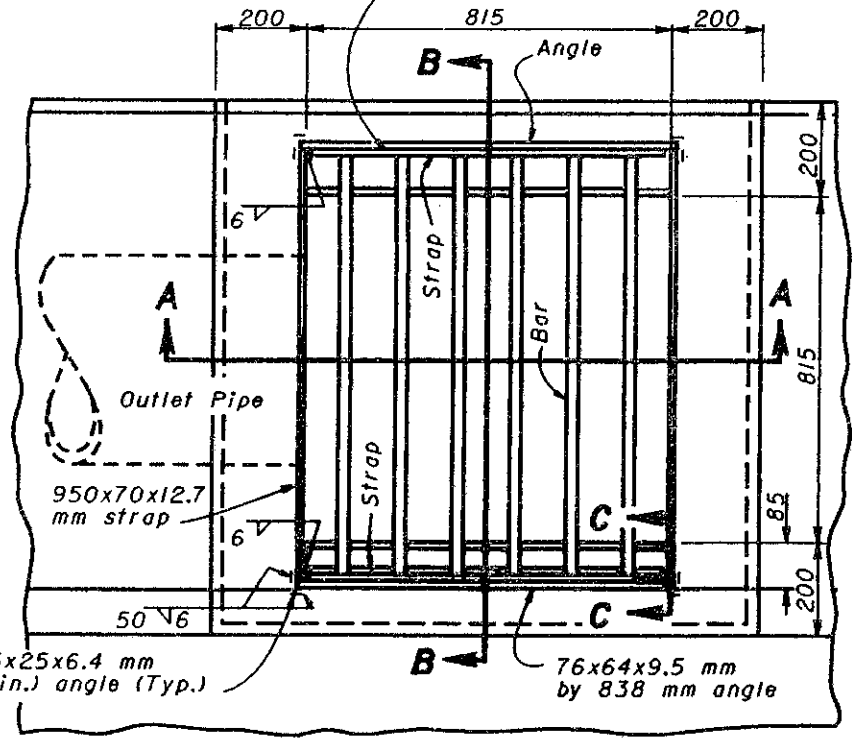

PLAN OF CATCH BASIN

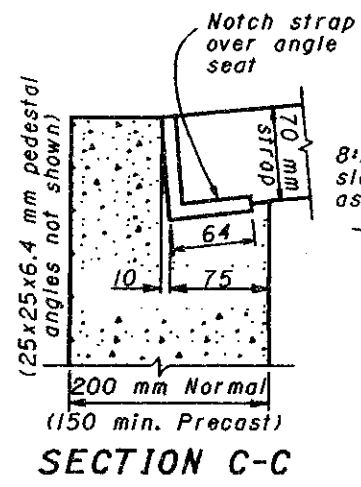

SECTION C-C

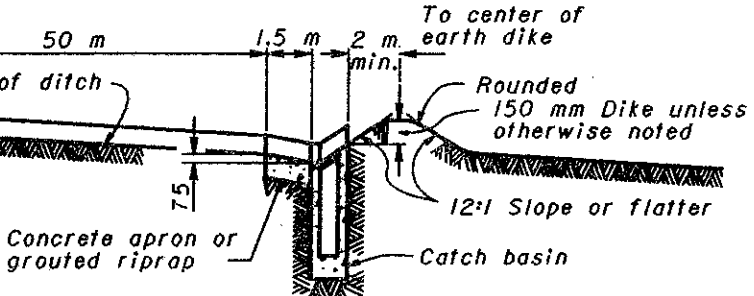

VERTICAL SCALE DISTORTED

PROFILE OF ROADSIDE DITCH GRADING AT CATCH BASIN

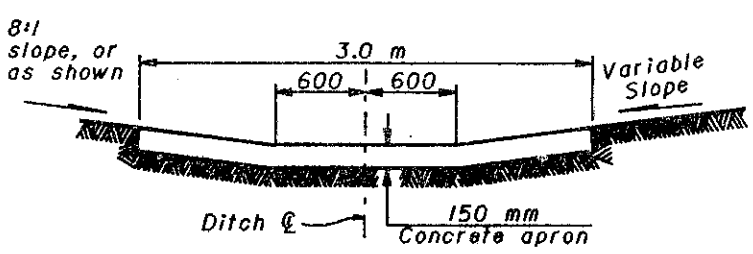

UPSTREAM END VIEW OF CONCRETE APRON OR GROUDED RIPRAP

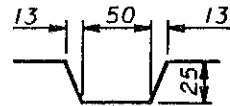

KEY JOINT