

PLAN

25.5° bend and additional  $\emptyset$  hole required only for use with Type B Anchor Assembly

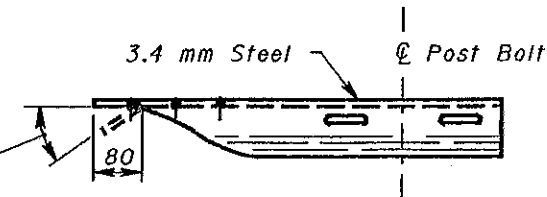

PLAN

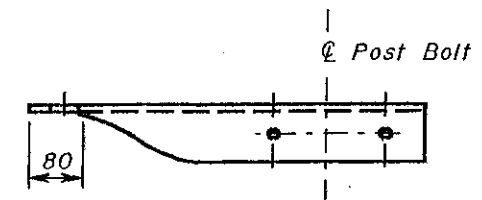

PLAN

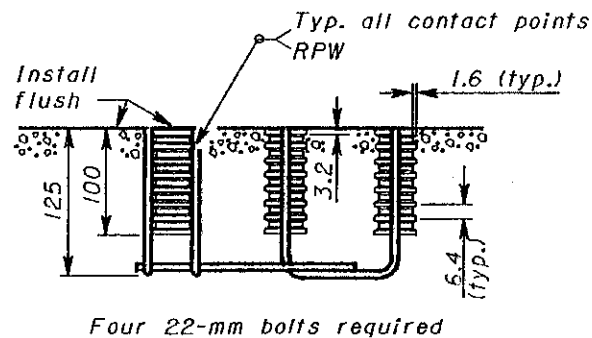

ELEVATION

**CONCRETE INSERT ANCHOR ASSEMBLY (W-BEAM ONLY)**

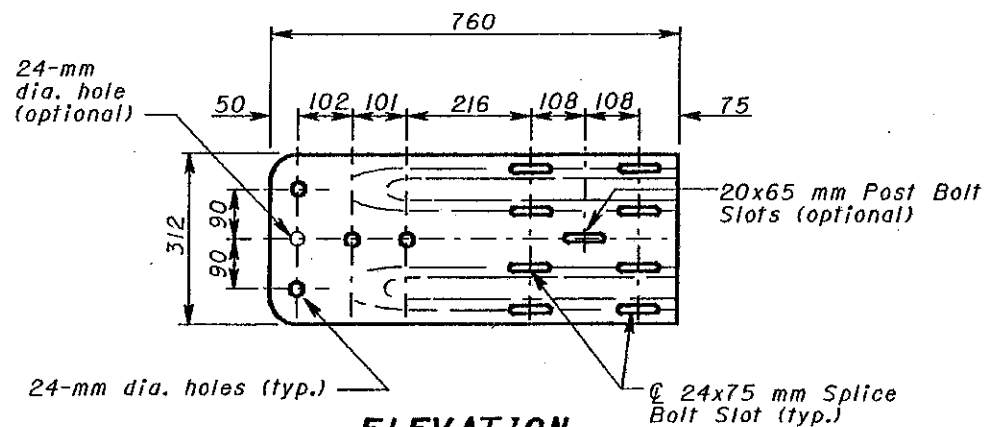

ELEVATION

**W-BEAM TERMINAL CONNECTOR**

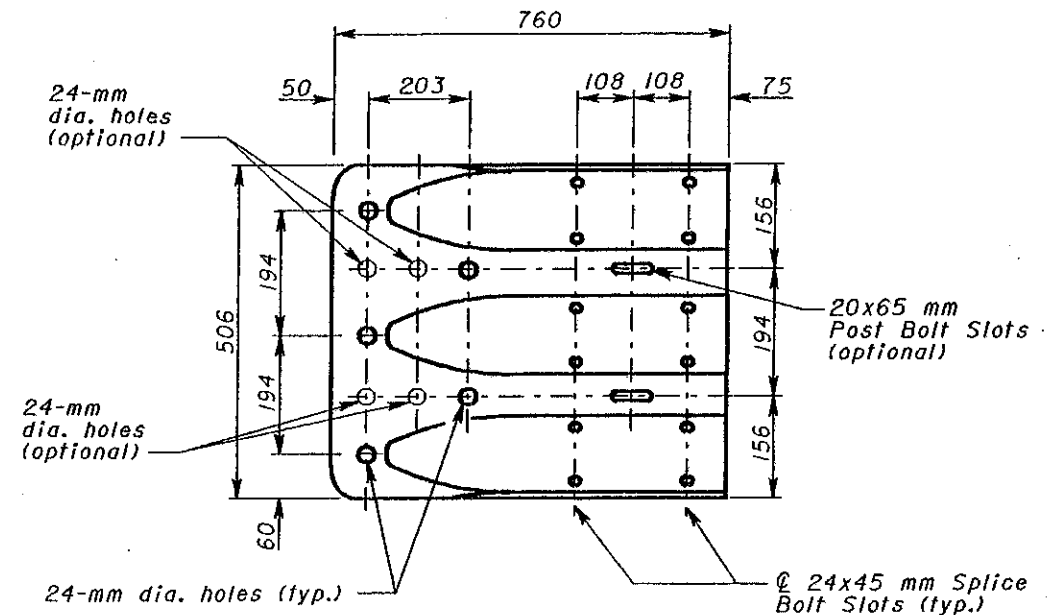

ELEVATION

**THRIE-BEAM TERMINAL CONNECTOR**

All dimensions are in millimeters unless otherwise noted.

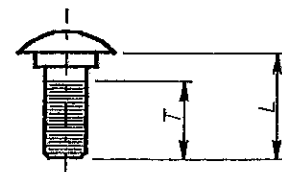

L (mm)	T min. (mm)	Bolt Use
455 (Standard Rail)	85	Type 5: WP/WB, PB
660 (Barrier Rail)		
255	60	Type 4: WP Type 5: SP/WB, PB
50	35	Type 4: SP
32	Full	Splice Bolt

WP- wood post      WB- wood blackout  
 SP- steel post      PB- plastic blackout  
 Longer bolt may be needed for round WP larger than 200 mm dia.

**BUTTON HEAD BOLT**  
 (For post and splice bolts)

**NOTE**

Refer to AASHTO M 180 for dimensional details of W-Beam and Thrie-Beam rail elements, related buffer and end sections, beam splices, post and splice bolts and nuts, and Type I W-Beam to Thrie-Beam Transition section.



OHIO DEPARTMENT OF TRANSPORTATION

**GUARDRAIL DETAILS**

DATE  
 11-30-94  
 10-21-97

STANDARD CONSTRUCTION DRAWING **GR-1.1M**

APPROVED *Randy T. Sutherland*