

URBAN-RESIDENTIAL AND BUSINESS

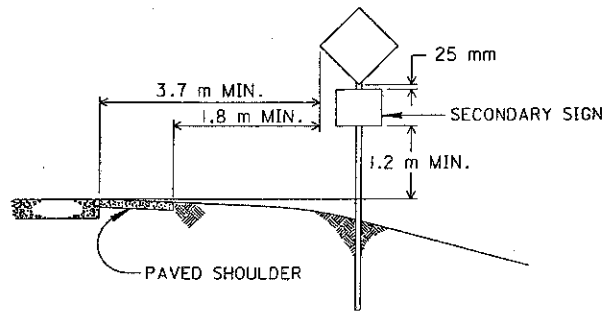

RURAL
W/SECONDARY SIGN

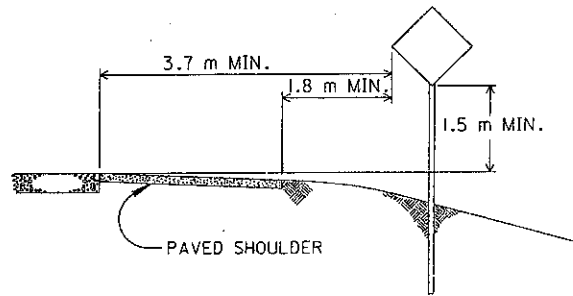

RURAL

NOTES

1. SEE DRAWING TC-41.20M FOR DETAILS ON YIELDING SUPPORTS.
2. ALL SIGNS SHALL BE PLACED 90° TO THE ROADWAY, EXCEPT PARKING SIGNS WITH ARROW SHALL BE SET AT AN ANGLE OF NOT LESS THAN 30° NOR MORE THAN 45° WITH A LINE PARALLEL TO THE FLOW OF TRAFFIC.
3. A CLEARANCE OF 0.3 m IS PERMISSIBLE WHERE SIDEWALK WIDTH IS LIMITED OR WHERE EXISTING POLES ARE CLOSE TO THE CURB.
4. SEE DRAWINGS TC-52.10M AND TC-52.20M FOR DIMENSIONS BETWEEN SUPPORTS.

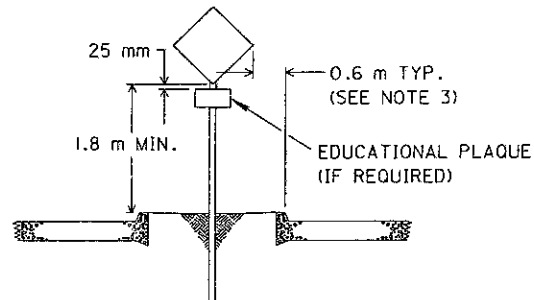

MEDIAN

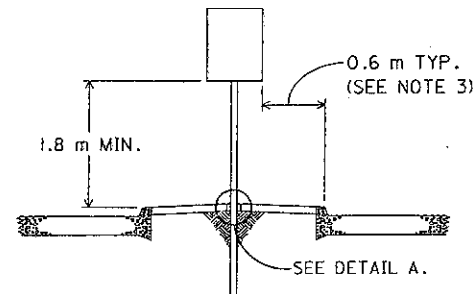

PAVED MEDIAN

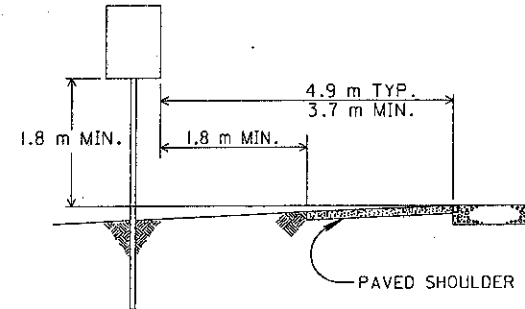

MEDIAN-EXPRESSWAY OR FREEWAY

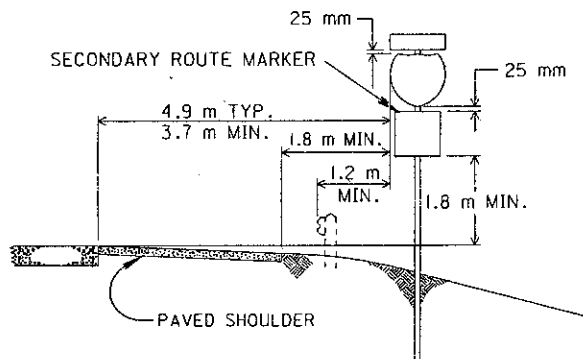

EXPRESSWAY OR FREEWAY

W/SECONDARY SIGN

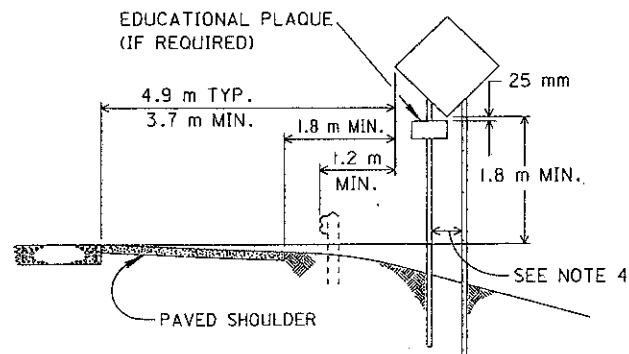

EXPRESSWAY OR FREEWAY

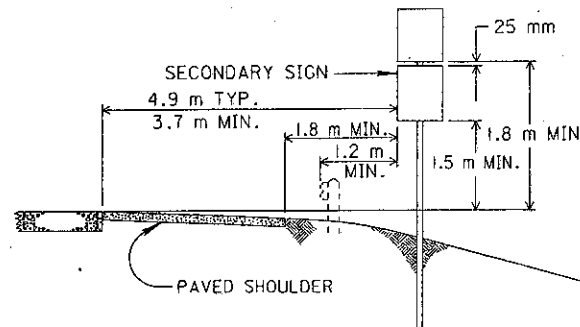

EXPRESSWAY OR FREEWAY

W/SECONDARY SIGN

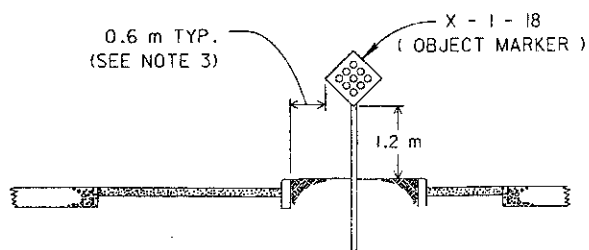

EXPRESSWAY OR FREEWAY

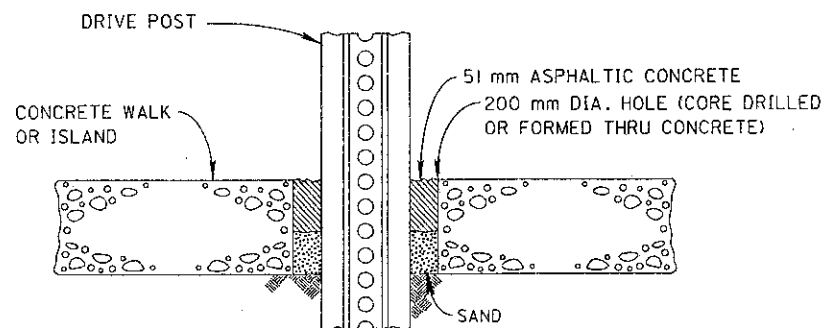

DETAIL A.

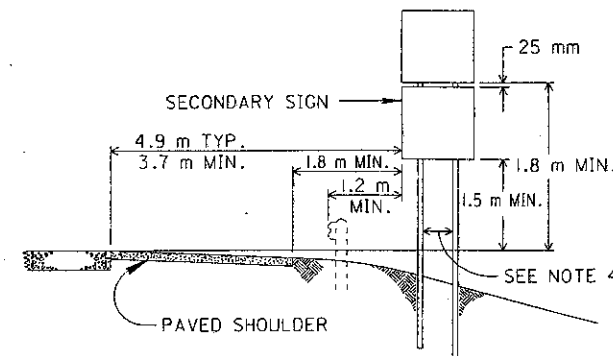

EXPRESSWAY OR FREEWAY

W/SECONDARY SIGN

METRIC

BUREAU OF DESIGN SERVICES
DIVISION OF HIGHWAYS
OHIO DEPARTMENT OF TRANSPORTATION

TRAFFIC CONTROL

DATE
03/31/94

TYPICAL SIGN PLACEMENT
REGULATORY, WARNING
AND ROUTE MARKER SIGNS

STANDARD
CONSTRUCTION
DRAWING
TC-42.20M

APPROVED *[Signature]* ENGR. OF DESIGN SERVICES