

SECTION - ITEM 451 & 452

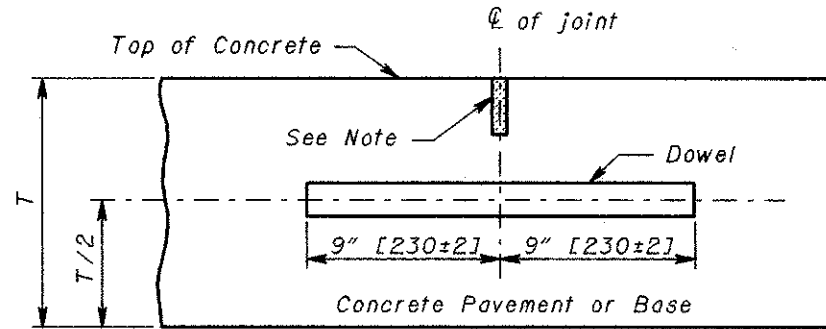

SECTION THROUGH CONSTRUCTION JOINT

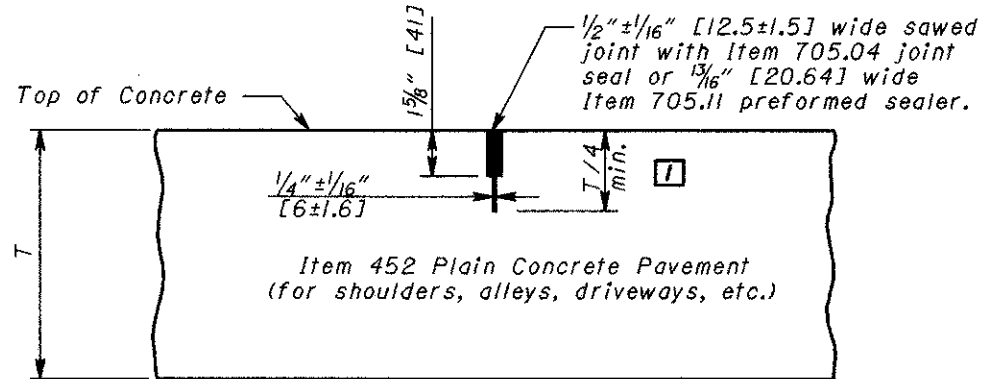

SECTION - ITEM 452

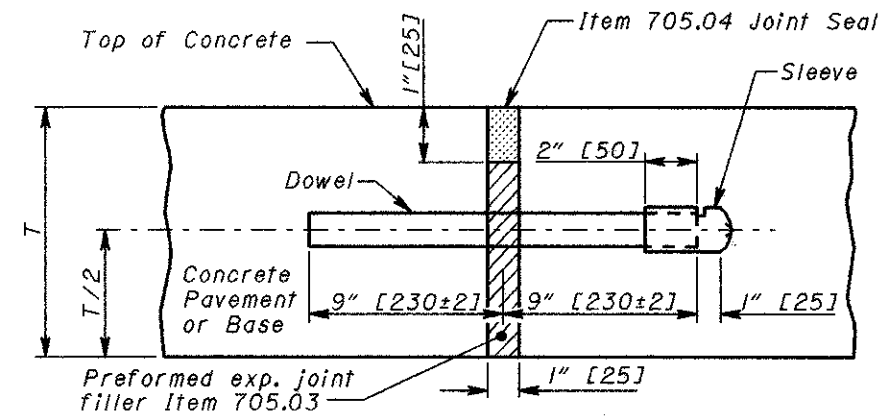

SECTION THROUGH EXP. JOINT

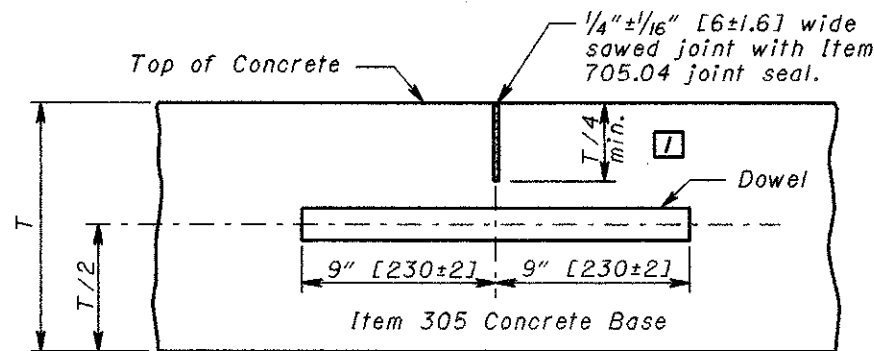

SECTION - ITEM 305

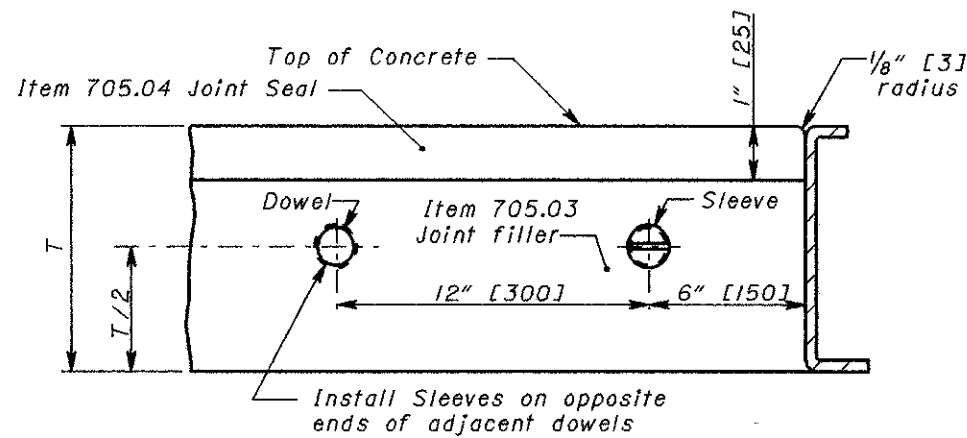

SIDE ELEVATION OF EXP. JOINT  
(through Concrete Pavement or Base)

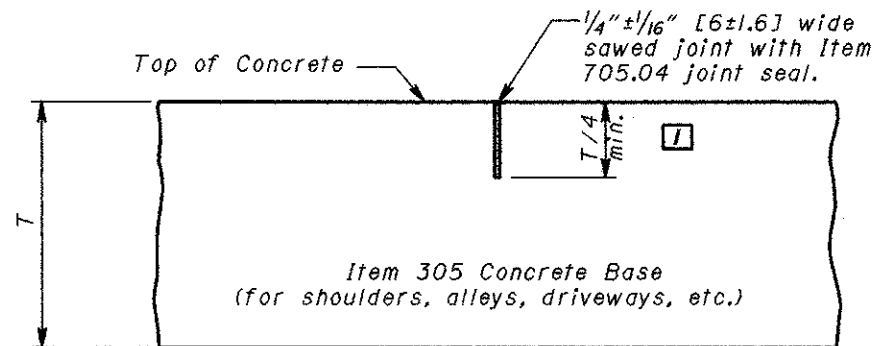

SECTION - ITEM 305

CONTRACTION JOINTS

EXPANSION JOINT

## NOTES

**GENERAL:** Notes and details shown on this drawing shall be considered in conjunction with and supplemental to the pertinent specifications for portland cement concrete pavement and bases, and related incidentals.

**JOINT COMPONENTS:** This drawing is intended for use with a uniform depth pavement. When the project involves the placing of variable depth pavement, the joint components shall be held in place in accordance with the method shown in the plans or as approved by the Engineer.

**CONTRACTION JOINTS:** Contraction joints in Item 305 Concrete Base shall be dowelled where they are located in mainline pavement, ramps, acceleration/deceleration lanes, or collector/distributor lanes, or in shoulders within 500' [150 m] of a pressure relief joint.

Contraction joints in Item 305 Concrete Base shall not be dowelled in alleys, private drives, or commercial drives.

Contraction joints of the type specified shall be spaced in accordance with the CONTRACTION JOINT SPACING Table.

CONTRACTION JOINT SPACING	
Types of Pavement or Base	Maximum Spacing Between Joints
Item 451 Reinforced Concrete Pavement	21' [6.5 m]
Item 452 Plain Concrete Pavement	15' [4.6 m]
Item 305 Concrete Base	15' [4.6 m]

**CONSTRUCTION JOINTS:** In Item 305 Concrete Base, a construction joint shall not be located closer than 6' [1.8 m] to another parallel joint.

Kerf and seal conforming in all respects to details shown for contraction joints shall be provided at each construction joint in concrete pavement and base.

**SEALING BASE CONTRACTION JOINTS:** All contraction joints for concrete base shall be sealed as detailed on this drawing and the cost included in the unit price bid for Item 305.

## LEGEND

□ Where  $T > 10''$  [255], the sawcut depth shall be  $T/3$ .

THIS DRAWING REPLACES BP-2.2M DATED 10-21-97.

OHIO DEPARTMENT OF TRANSPORTATION	DATE
REVISIONS	7-28-00
STDS. ENGR. M. EVANS	ROADWAY DESIGN ENGINEER
DRAWN D. Focke	
ROADWAY ENGINEERING SERVICES	
STANDARD ROADWAY CONSTRUCTION DRAWING	
TRANSVERSE PAVEMENT JOINTS	
NUMBER BP-2.2	