

PROJECT DESCRIPTION

THIS PROJECT CONSIST OF TOTAL REPLACEMENT OF APPROXIMATELY 1.90 KILOMETERS OF FOUR LANE DIVIDED AND UNDIVIDED, URBAN ARTERIAL ROADWAY, SITUATED IN THE CITY OF WILLOUGHBY. THE PROJECT HAS AN EAST-WEST ORIENTATION STARTING APPROXIMATELY AT EAST 364th ST. AND ENDING AT STATE ROUTE 20, ERIE ST. .

PERMANENT SEEDING QUANTITY CALCULATED IS A 8 m WIDE STRIP ALONG 900 mm STORM SEWER AND AN ADDITIONAL 3 m ON EACH SLOPE NEAR THE RAILROAD.

USGS QUADRANT NO. 41081-F4
EASTLAKE, OHIO
LONGITUDE: 81°25'05"
LATITUDE: 41°38'33"

* LONGITUDE AND LATITUDE TO APPROX. CENTER OF PROJECT

LEGEND

- ▨ CONCRETE SLOPE PROTECTION
- ▣ CATCH BASIN (6 METERS SILT FENCE), CB-3A, 6
- ▣ CATCH BASIN (8 METERS SILT FENCE), CB-3
- ▣ CATCH BASIN (6 METERS SILT FENCE), CB 2-2B, 2-3
- MANHOLE
- MANHOLE, ADJUSTED TO GRADE
- ◻ EXISTING CATCH BASIN
- ✕ FILTER FABRIC FENCE (4 METERS SILT FENCE PER CROSSING)
- SWALE FLOW

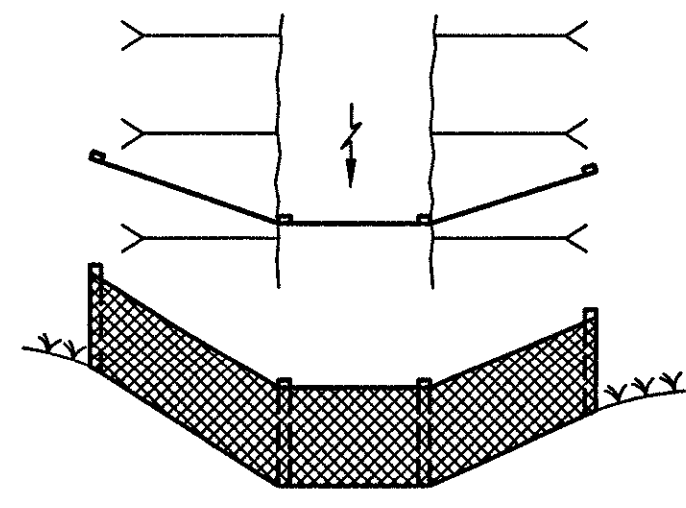

PLACEMENT OF SILT FENCE IN SWALE AREAS AS PER STANDARD DRAWING DM 4.4M
NTS

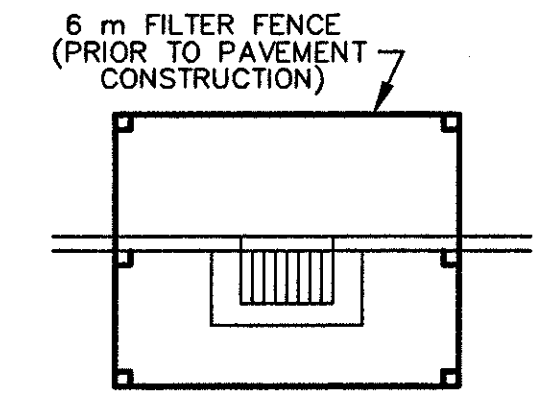

CATCH BASIN BOXOUT W/FILTER FABRIC FENCE AS PER STANDARD DRAWING DM 4.3M
NTS

| PROJECT DATA | |
|-------------------------------------------------|-------------------|
| TOTAL AREA (RIGHT-OF-WAY) | = 23.5 AC. |
| AREA TO UNDERGO EXCAVATION, FILLING, OR GRADING | = 16.7 AC. |
| RUNOFF COEFFICIENT FOR PRE-CONSTRUCTION SITE | = .79 |
| RUNOFF COEFFICIENT FOR POST CONSTRUCTION SITE | = .79 |
| SOIL DATA | SEE SOIL PROFILES |
| IMMEDIATE RECEIVING WATERS | CHAGRIN RIVER |

| ITEM NO. | ESTIMATED QUANTITIES | | | |
|---------------------------|----------------------|-----------------------------------------|------------------------------------------------|----------------------|
| | 877 | 877 | 870 | 870 |
| LOCATION | | | | |
| | SIDE | TEMPORARY PERIMETER FILTER FABRIC FENCE | TEMPORARY INLET PROTECTION FILTER FABRIC FENCE | SEEDING AND MULCHING |
| | METERS | METERS | SQ. M. | KG |
| CATCH BASINS NO. 3 | L&R | 56 | | |
| CATCH BASINS NO. 3A, 2-2B | L&R | 150 | | |
| EXISTING CATCH BASINS | R | 24 | | |
| 4+160 TO 4+880 | | | 5500 | 160 |
| SWALE CROSSINGS | L&R | 68 | | |
| 4+370 TO 4+505 | R | 195 | | |
| 4+430 TO 4+535 | L | 105 | | |
| 4+595 TO 4+790 | R | 385 | | |
| 4+630 TO 4+790 | L | 160 | | |
| TOTAL CARRIED TO SHEET 67 | | 913 | 230 | 5500 160 |