

NOTES

- ON MULTI-LANE APPROACHES, THE TRANSVERSE LINES USED WITH THE RAILROAD SYMBOLS SHALL EXTEND ACROSS ALL APPROACH LANES AND SYMBOLS SHALL BE PLACED IN EACH APPROACH LANE.
- THE RAILROAD SYMBOL SHALL BE LOCATED SO THAT THE W-94, "RAILROAD ADVANCE WARNING SIGN", IS WITHIN THE TWO TRANSVERSE BOUNDARY LINES OF THE RAILROAD SYMBOL. THE STOP LINE SHALL BE LOCATED FOR BEST SIGHT DISTANCE WITHIN 5 METERS TO 15 METERS OF THE NEAR EDGE OF THE TRACKS. WIDTH OF "X" MAY VARY ACCORDING TO LANE WIDTH. STOP LINES SHALL BE APPROXIMATELY 2.4 METERS FROM A GATE (IF PRESENT).
- PREFERABLY, THE WORD "SCHOOL" SHOULD BE CONTAINED IN A SINGLE LANE. ON ONE LANE APPLICATIONS, THE TRANSVERSE LINES SHALL EXTEND ACROSS THE LANE WHICH APPROACHES THE ZONE WITH THE WORD "SCHOOL" CENTERED ACROSS THAT LANE. FOR TWO APPROACH LANES, EACH LANE SHOULD HAVE A SEPARATE WORD "SCHOOL" CENTERED ACROSS IT. ON TWO LANE, TWO WAY ROADWAYS WITH INSUFFICIENT PAVEMENT WIDTH, THE WORD AND TRANSVERSE LINES SHALL EXTEND ACROSS BOTH LANES OF TRAFFIC. ON FOUR LANE, TWO WAY ROADWAYS WITH INSUFFICIENT PAVEMENT WIDTH, THE WORD AND TRANSVERSE LINES SHALL EXTEND ACROSS BOTH LANES ENTERING THE SCHOOL ZONE. CENTER OR LANE LINES SHALL NOT PASS THROUGH THE "SCHOOL" MARKING.
- THE STOP LINE SHOULD BE PLACED WHERE CROSS-CORNER VISION IS MAXIMUM, IN NO CASE MORE THAN 9.1 METERS OR LESS THAN 1.2 METERS FROM THE NEAREST EDGE OF THE INTERSECTING ROADWAY. FOR NORMAL INTERSECTIONS A MAXIMUM DISTANCE OF 3 METERS IS RECOMMENDED.

IF A MARKED CROSSWALK IS PRESENT, THE STOP LINE SHOULD BE PLACED 1.2 METERS IN ADVANCE OF AND PARALLEL TO THE NEAREST CROSSWALK LINE.
- FOR TRAFFIC PAINT AND POLYESTER APPLICATION, TEMPLATE GAPS SHALL BE FILLED WITH MARKING MATERIAL IN ACCORDANCE WITH 641.03. FOR EXTRUDED THERMOPLASTIC MATERIAL, THESE GAPS MAY REMAIN UNFILLED IN ACCORDANCE WITH 644.03.
- USE STANDARD DIMENSIONS CONFORMING TO REQUIREMENTS OF DMUTCD SECTIONS 3B-40, 3B-41 AND 3B-43 WHICH CONFORMS TO THE 1977 METRIC EDITION STANDARD ALPHABETS FOR HIGHWAY SIGNS AND PAVEMENT MARKING WITH ERRATA.

* - INDICATES STATION REFERENCE POINT

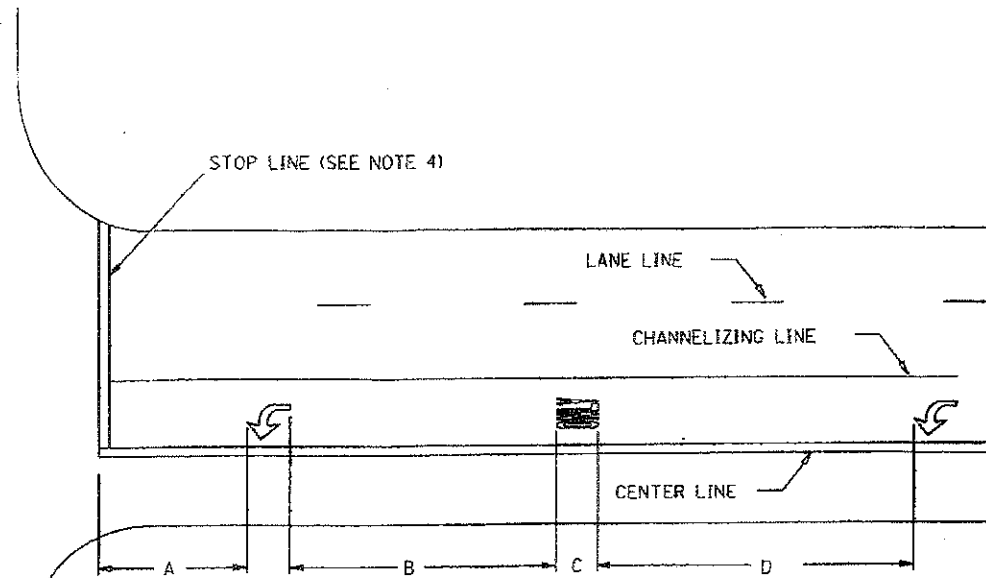
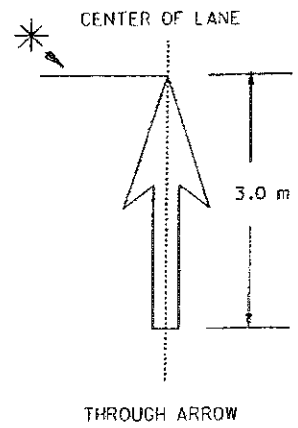
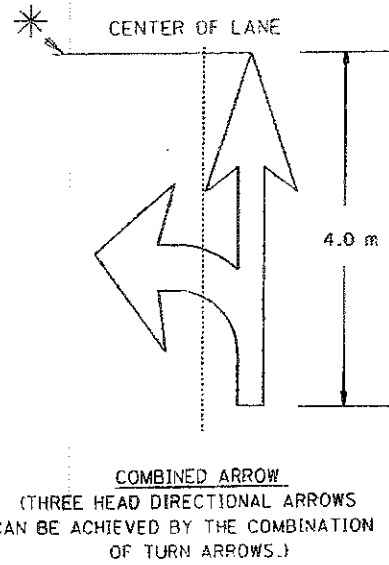
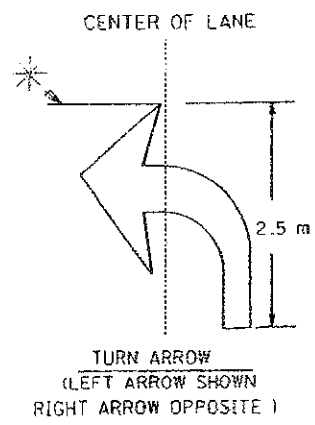

TYPE	DIMENSIONS (METERS)			
	A	B	C	D
RURAL	9 MIN.	10-25	2.5	10-25
URBAN	3 MIN.	7-18	1.8	7-18

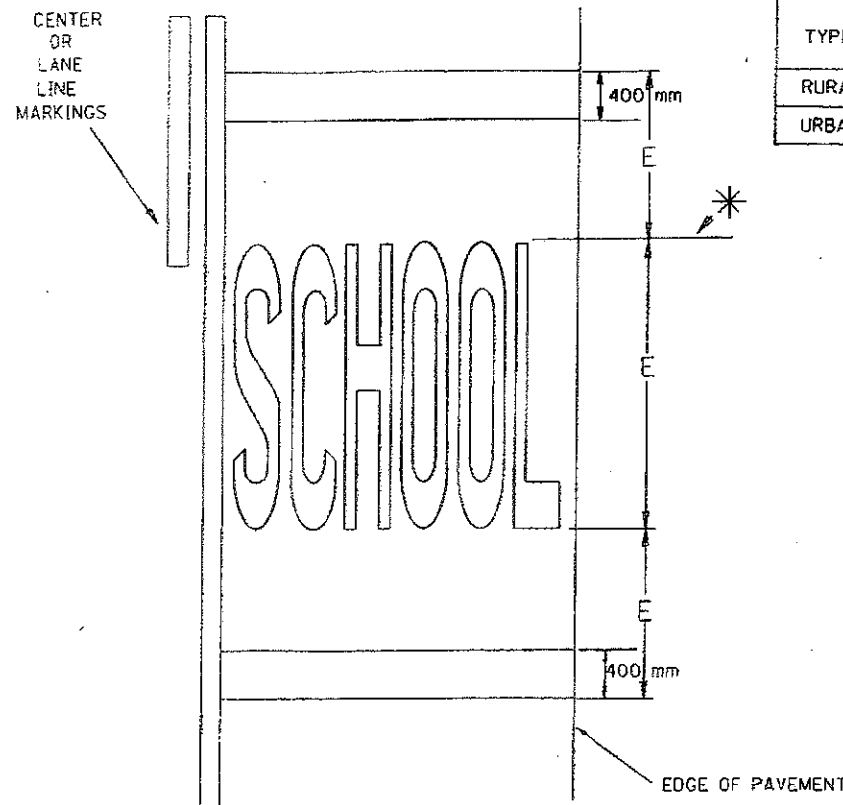

TYPE	E (MILLIMETERS)
	STANDARD
RURAL	2500
URBAN	1800

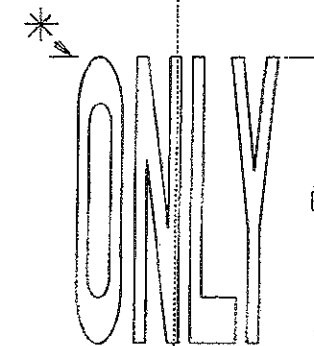
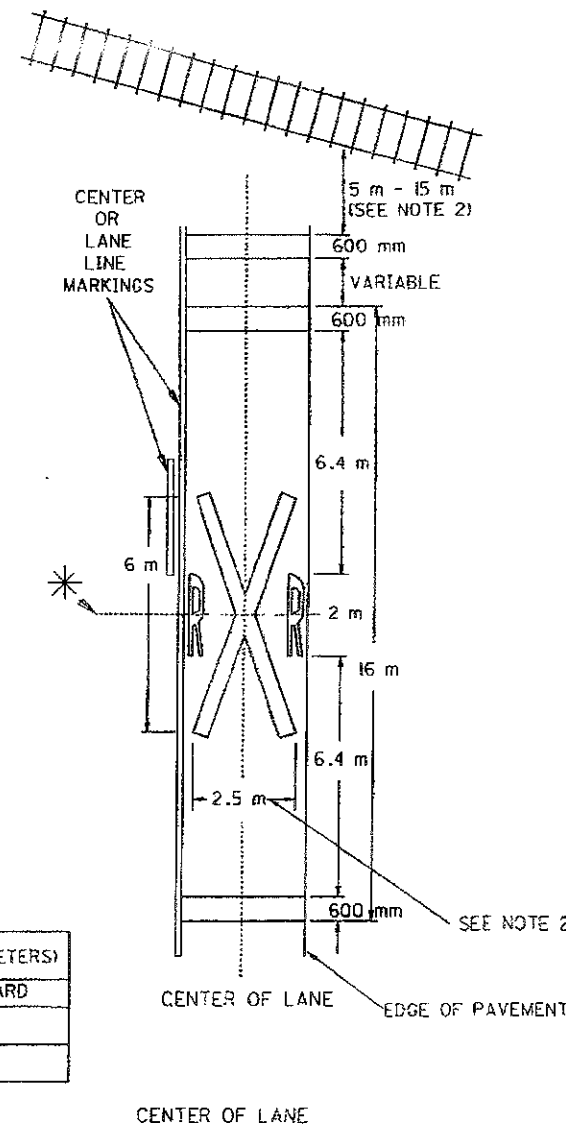

M E T R I C	
BUREAU OF DESIGN SERVICES DIVISION OF HIGHWAYS OHIO DEPARTMENT OF TRANSPORTATION	
TRAFFIC CONTROL	DATE 09/01/93
WORDS, SYMBOLS AND ARROWS	
STANDARD CONSTRUCTION DRAWING	TC-71.10M
APPROVED <i>[Signature]</i> ENGR. OF DESIGN SERVICES	